

# Assembly instruction for gennaker halyard crane 508-060-01R

The purpose of this crane is to bring the gennaker halyard on a masthead rig further forward. This in order to create clearance for a Seldén GX halyard swivel and prevent interference with the forestay.

## Note:

Only for use with gennakers, not Code 0 sails.

Max Boat RM: 35kNm

Designed for use on Seldén headboxes with 30 mm internal width.

Halyard to be led via forward starboard headbox sheave.

Max extension from forward edge of headbox is 55 mm.

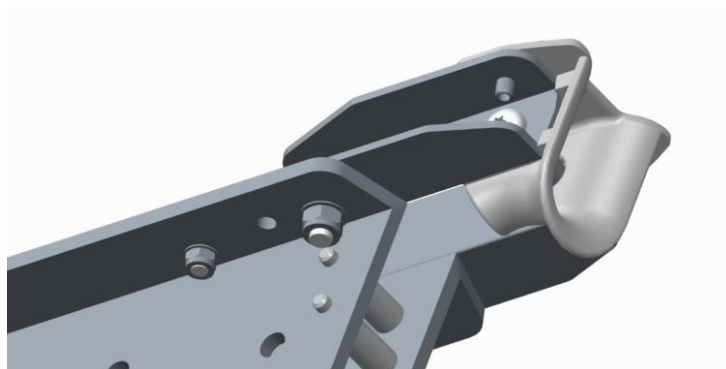

## Drilling instructions

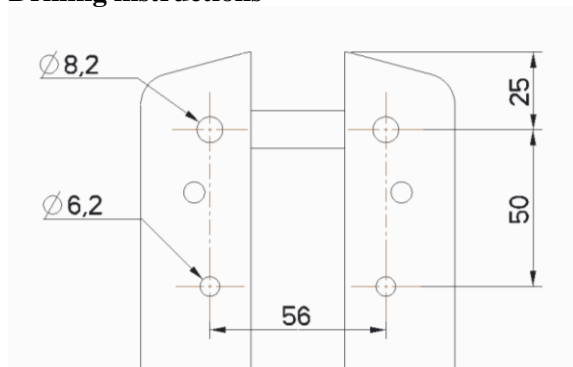

## Required tools:

Ruler

Pen

Drill bit  $\varnothing 6\text{mm}$

Drill bit  $\varnothing 8\text{mm}$

Spanner

Torx set

