



BAVARIA. CRUISER LINE 2011.

Designed by Farr Yacht Design & BMW Group DesignworksUSA.





INNOVATIVE YACHTEN./ INNOVATIVE YACHTS.

Mit der CRUISER 55 fiel der Startschuss für eine neue Generation von BAVARIA YACHTEN. Mit sechs Schiffen ist die Line nun komplett.

Die neuen, modernen Yachten bilden eine perfekte Mischung aus bester Qualität, maximaler Sicherheit, höchstem Komfort, optimaler Performance und funktionalem Design. Übertroffene Testergebnisse in der internationalen Fachpresse bestätigen unsere neuen Maßstäbe im Yachtbau.

Einer der Garantoren für diesen Erfolg liegt in der Konstruktionspartnerschaft zwischen der BAVARIA Entwicklung gemeinsam mit Farr Yacht Design und BMW Group DesignworksUSA, einer Tochterfirma der BMW Group.

Vor Anker oder am Wind, die CRUISER Linie vermittelt das Lebensgefühl von Freiheit und Luxus an Bord einer modernen Yacht. Das Längen-Portfolio von 32 bis 55 Fuß bietet Ihnen die perfekte Plattform, um darauf Ihre persönliche BAVARIA CRUISER zu konfigurieren, unabhängig davon, wo Sie segeln und welche besonderen Ansprüche Sie haben.

Gestalten Sie die Räume nach Ihren eigenen Wünschen. Die Auswahl aus drei verschiedenen Holzarten und elf Polstervarianten in Stoff und Kunstleder macht es möglich!

Holen Sie seglerisch alles aus einem Satz „State-of-the-Art“ Membran-Segel oder erleichtern Sie sich das Manövrieren durch ein Bugstrahlruder.

Ihre Wünsche und Ansprüche sind das Maß der Dinge.

Ihr BAVARIA Team.

The CRUISER 55 marked the beginning of a new generation of BAVARIA yachts. With six models in line the range is now completed.

The new, modern yachts make the perfect mix of high quality, safety, comfort, performance and functional design. Outstanding test results in the international trade press reaffirm our new standards for building yachts.

One guarantor for this success lies in the partnership between BAVARIA's development department with Farr Yacht Design and BMW Group DesignworksUSA, a subsidiary of the BMW Group.

Whether at anchor or sailing close-hauled, the CRUISER line communicates an attitude of a life in freedom and luxury aboard a modern yacht. The length portfolio stretches from 32 to 55 feet and offers a perfect platform to start from to configure your individual BAVARIA CRUISER, independent of where you wish to sail or what your standards are.

Design the rooms according to your own desires – the choice among three different types of wood and eleven variants of upholstery, from fabric to artificial leather, makes it possible.

Get the most out of sailing with a state-of-the-art membrane-sailset or make manoeuvring easier with a bow thruster.

Your standards and desires are the measure of all things.

Your BAVARIA Team.



BOAT FINDER.

CRUISER

55

Seite./ Page 10

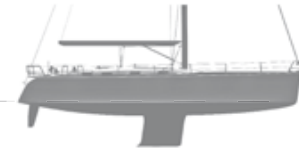
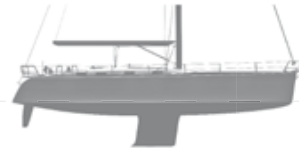
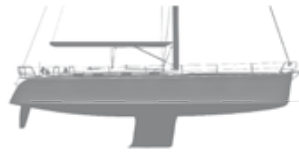

50

Seite./ Page 20

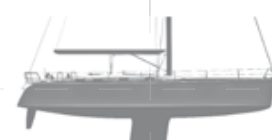
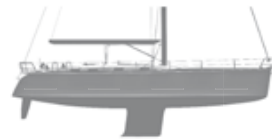
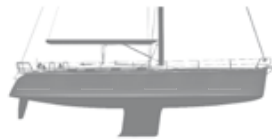

45

Seite./ Page 45

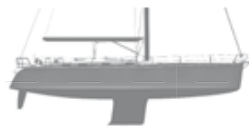

40

Seite./ Page 32

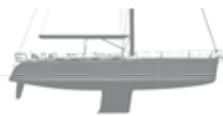

36

Seite./ Page 42



32

Seite./ Page 50



2 Kabinen./ Cabins.

3 Kabinen./ Cabins.

4 Kabinen./ Cabins.

5 Kabinen./ Cabins.



INHALTSANGABE./ CONTENT OVERVIEW.

BOAT FINDER.	02
FEATURES./ CRUISER.	04
INTERIEUR./ INTERIOR. WOODS.	08
INTERIEUR./ INTERIOR. UPHOLSTERY.	08
CRUISER 55.	10
CRUISER 55 INTERIEUR./ INTERIOR.	14
CRUISER 55 KABINEN-VERSIONEN./ CABIN VERSIONS.	16
CRUISER 55 TECHNISCHE DATEN./ TECHNICAL DATA.	18
CRUISER 50.	20
CRUISER 50 INTERIEUR./ INTERIOR.	21
CRUISER 50 TECHNISCHE DATEN./ TECHNICAL DATA.	22
CRUISER 45.	24
CRUISER 45 INTERIEUR./ INTERIOR.	28
CRUISER 45 TECHNISCHE DATEN./ TECHNICAL DATA.	30
CRUISER 40.	32
CRUISER 40 INTERIOR./INTERIOR.	36
CRUISER 40 TECHNISCHE DATEN./ TECHNICAL DATA.	38
CRUISER 40 S TECHNISCHE DATEN./ TECHNICAL DATA.	40
CRUISER 36.	42
CRUISER 36 INTERIEUR./ INTERIOR.	46
CRUISER 36 TECHNISCHE DATEN./ TECHNICAL DATA.	48
CRUISER 32.	50
CRUISER 32 INTERIEUR./ INTERIOR.	54
CRUISER 32 TECHNISCHE DATEN./ TECHNICAL DATA.	56
DIE WERFT./ THE SHIPYARD.	58
PARTNER./ PARTNERS.	60

FEATURES./ CRUISER.



Die Doppelradsteuerung auf CR 55, 50, 45, 40.
The twin-steering system of the CR 55, 50, 45, 40.



Die Genuaschienen auf dem Decksaufbau sorgen sowohl für ein aufgeräumtes Seitendeck als auch für hervorragende Am-Wind-Eigenschaften.
The genoa tracks are positioned on top of the coachroof, ensuring uncluttered gangboards as well as excellent up-wind characteristics.



Badeplattform in der Breite des Spiegels.
Bathing platform spans over the entire width of the stern.



Alle Fallen und Strecker werden sauber ins Cockpit geführt (Bild CR 40)— für die einfache und zentrale Bedienung.
All halyards and lines are lead directly into the cockpit for easy and centralized handling.



Große Backskisten, passend für die jeweilige Rettungsinselgröße.
Large cockpitlocker space, ideal for each size of lifesaving island.



Ergonomisch platzierte Fallen- und Schot-Winschen.
Ergonomically-placed halyards and sheat winches.



Roll-Groß- und -Vorsegel ermöglichen ein sicheres und leichtes Handling bei allen Schiffsgrößen.
Furling main and head sail ensure safe and easy handling for any size of boat.



Decksaufbau Design – Durch den abge-
schrägten Decksaufbau fällt mehr
Tageslicht in das Innere des Schiffes.
Gleichzeitig versteift er die Decks-
konstruktion.

Coach roof design – with the sloped
coach roof more daylight can reach the
interior of the boats. At the same time,
it strengthens the decks construction.



Doppelte Ruderblätter auf der CR 45, 50 und 55.
Twin rudders with the CR 45, 50 und 55.



V ersenkbarer GPS Plotter im Cockpittisch*.
The GPS chart plotter can be stored within the cockpit table.*



Modernes 9/10 Rigg mit breiten
Saligen und außen liegenden Wanten-
püttingen ermöglichen hervorragende
Amwindeigenschaften, optimale Kraft-
einleitung in die Rumpfstruktur und ein
breites Laufdeck.

Modern 9/10 rigg with broad spreaders
allows excellent sailing characteristics,
optimal force transmission to the hull
structure and a broad side deck.



*Option



Perfekter Stand für den Steuermann durch ausklappbare Fußstützen (CR 45, 50 & 55).

Perfect position for the helmsman thanks to fold-out foot stands (CR 45, 50 & 55).



Flush, bündig eingelassene Luken im Deck. Flush hatches ensure an uncluttered deck.



BAVARIA Doppel-Großschotsystem – ermöglicht genaues Trimmen ohne Traveller und sicheres Halsen.

BAVARIA double main sheet system – enables exact trimming without traveller as well as safe gybing.



Viel Schutz durch hohe Sprayhoods* und Voll-Biminis*, gegen Wind, Wetter und Sonne.

Good cover through high sprayhoods* and complete biminis*, against wind, weather and sun.



FSC Umwelt zertifiziertes Holz auf den Laufdecks.*

FSC-certified environmentally friendly wood on side decks.*



Dingy-Garage (CR 55).

Dinghy garage (CR 55).



Ausfahrbarer und abnehmbarer Gennakerbaum*.
Extendible and removable gennaker boom.*



BAVARIA. INTERIEUR./ INTERIOR. WOODS.



Bei allen Yachten der CRUISER-Serie unterstreicht das auch im Detail durchdachte Interieur unser überdurchschnittliches und wohnliches Raumangebot.

Darüber hinaus legen wir ganz besonderen Wert darauf, dass mehr als großzügige Stauräume in unsere Interieurkonzepte funktional integriert sind, um auch auf längeren Fahrten mit voller Mannschaft komfortabel reisen zu können.

Als Zentrum des Wohnens an Bord sehen wir unsere Salons. Der Komfort und die Funktionalität der Sitzgruppe um den Tisch kann durch eine Vielzahl von Optionen nach Ihren persönlichen Wünschen individuell ausgestattet werden. Sie können heute bereits aus 11 verschiedenen Polsterbezügen und drei verschiedenen Holzarten für den Innenausbau auswählen.

Unsere Pantrys sind ein weiterer, wichtiger Bestandteil der Konzepte unserer Yachten. Die klassische und vollständige Ausstattung unserer Pantrys integrieren sich gekonnt in das Interieur. Wünschen Sie sich eine Mikrowelle für Ihre Pantry? Kein Problem! Auch hierfür haben wir bereits einen anspruchsgerechten Platz vorgesehen.



Standard Mahagoni
Standard Mahagony



Option Eiche
Option Oak



Option Walnuss
Option Walnut

BAVARIA. INTERIEUR./ INTERIOR. UPHOLSTERY.

Die zeitlose Moderne der neuen CRUISER-Linie bestimmt auch die Ausstattung der Nasszellen unserer Schiffe. "Elegante Funktion" umschreibt die Konzepte dieser Lebensräume an Bord sehr treffend. Leicht zu pflegende Flächen, ergonomisch angeordnete Details, stilvolle Formen und die exklusive Erscheinung der Holzteile geben den Nasszellen einen zukunftsweisenden, aber auch behaglichen Charakter.

Das Gesamtkonzept aus individuellem Interieur und komfortablem Wohnen in unseren Schiffen findet seine Abrundung in den einzelnen Kabinen.

Große Stehhöhen, viele Stauräume und Schränke, ansprechende Oberflächen und die durchlaufende Designlinie der neuen CRUISER-Yachten von BAVARIA geben diesen Bereichen eine private Atmosphäre, in der es sich gern - auch über längere Zeit - leben lässt.

In all our yachts of the CRUISER series the exceptional amount of space is underlined by the elaborate interior.

Furthermore, we attach great importance to integrating spacious stowage spaces into the design of the cabins to ensure comfortable travelling with a larger crew over longer periods of time.

The centre of living aboard our yachts is the salons. The comfort and functionality of the settee around the table can be adjusted to your own taste and choices through a great number of options. Today, eleven types of upholstery and three variants of wood are available for the interior.

Another important part of our concepts is the pantry. The classical and fully equipped pantries are integrated into the interior. Would you like a microwave in your pantry? No problem! We have made space for that.

The timeless modern spirit of the new CRUISER Line dictates the equipment of our wet rooms. "Elegant functionality" perfectly describes the concept of the living rooms aboard. Easily cleanable surfaces, ergonomically arranged details, stylish shapes and the exclusive appearance of the wooden elements – all these characteristics give our wet rooms a futuristic yet cosy atmosphere.

The entire concept of individual interior and comfortable living aboard our yachts is completed by the variations of cabin choices. Great height in the salon, plenty of stowage space and cupboards as well as appealing surfaces continue throughout the design line of the new BAVARIA CRUISER yachts and make a private atmosphere, in which it is enjoyable to spend longer periods and live in.

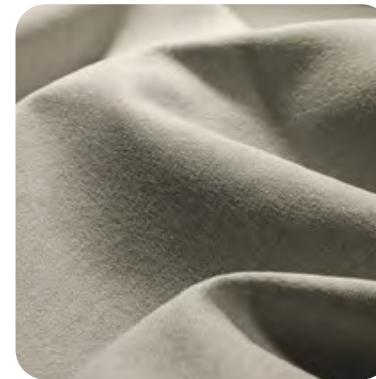

Melange Sand



Melange Navy

Standard



Melange Anthrazit

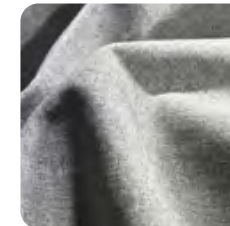

Melange Stone



Melange Mint

Option

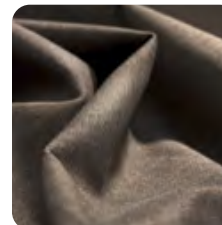

Melange Mocca

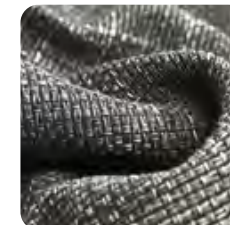

Melange Sturdy

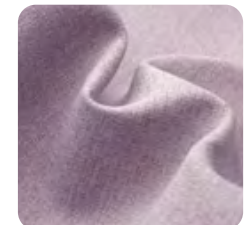

Melange Rosé

Option Kunstleder
Option artificial leather

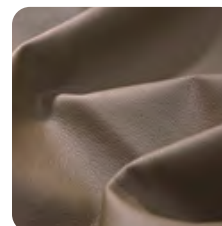

Coffee



Cognac

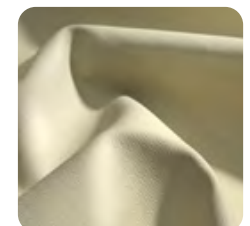

Champagner

BAVARIA./ CRUISER 55.





BAVARIA YACHTS



BAVARIA./ CRUISER 55.



INTERIEUR./ INTERIOR. CRUISER 55.



Nasszelle achtern./ Eigner-Kabine./ Eignerbad./ Kleiderschrank Stb./ Headroom aft./ Owners headroom./ Wardrobe Stb.



KABINEN-VERSIONEN./ CABIN VERSIONS. CRUISER 55.



3-Kabinen-Version./ 3-cabin version

Große Eigner-Kabine im Vorschiff, eine Backbord- und eine Steuerbord-Kabine, jeweils mit Nasszelle (Dusche/WC).

Spacious owner's cabin, port and starboard aft cabin, each equipped with a shower/toilet.



4-Kabinen-Version B./ 4-cabin version B:

Zwei Doppelbett-Kabinen im Vorschiff, jeweils mit Nasszelle (Waschbecken/WC) und einer zentralen Dusche, eine Backbord- und eine Steuerbord-Kabine, jeweils mit Nasszelle (Dusche/WC).

Two double bed cabins in foreship, each including a washing basin/toilet and a shared central shower, port and starboard aft cabins, each equipped with a shower/toilet.



4-Kabinen-Version A./ 4-cabin version A

Große Eigner-Kabine im Vorschiff mit Nasszelle (Dusche/WC), zwei Backbord-Kabinen (1x Doppelbett, 1x Stockbett) und eine Steuerbord-Kabine mit Nasszelle (Dusche/WC).

Spacious owner's cabin equipped with a shower/toilet, two port side aft cabins (1x double bed, 1x bunk bed) and a starboard aft cabin equipped with a shower/toilet.



5-Kabinen-Version./ 5-cabin version

Zwei Doppelbett-Kabinen im Vorschiff, jeweils mit Nasszelle (Waschbecken/WC) und einer zentralen Dusche, zwei Backbord-Kabinen (1x Doppelbett, 1x Stockbett) und eine Steuerbord-Kabine mit Nasszelle (Dusche/WC).

Two double bed cabins in foreship, each including a washing basin/ toilet and a shared central shower, two portside aft cabins (1x double bed, 1x bunk bed) and starboard aft cabin equipped with a shower/toilet.

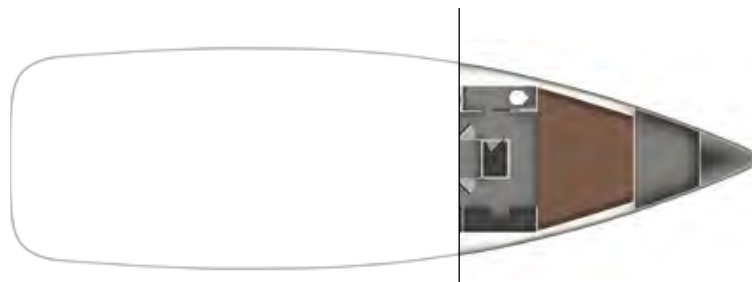

Eigner-Version nach Umbau der Charter-Version./ Owner's version after modification of the charter Version

Es besteht die Möglichkeit, auch nachträglich, aus zwei Doppelbett-Kabinen im Vorschiff eine einzelne Eigner-Kabine zu machen. Weitere Informationen dazu erhalten Sie bei Ihrem Bavaria-Händler.

There's also the possibility of converting the two double bed cabins in the forward area into a single owner's cabin – at a later date. For more information, please contact your local BAVARIA dealer.



TECHNISCHE DATEN./ TECHNICAL DATA. CRUISER 55. SEGELPLAN./ SAILPLAN.

Length overall	Gesamtlänge	16,75 m
Lenght hull	Rumpflänge	16,16 m
Length waterline	Länge Wasserlinie	14,96 m
Beam overall	Gesamtbreite	4,76 m
Draught Standard	Tiefgang Standard (Option)	2,35 m (1,90 m)
Unloaden weight	Leergewicht	17.500 kg
Engine	Motor	Yanmar
Engine Power hp	Motorleistung	81 kw (110 PS)
Fuel tank	Kraftstofftank	380 l
Water tank	Wassertank	700 l
Cabins	Kabinen	3/4/5
Berths	Kojen	6/8/10
Height in Salon	Stehhöhe im Salon	2,06 m
Main- & Headsail	Großsegel & Rollgenua (Standardausf.)	145 m ²
Height above Mast	Masthöhe über Wasserlinie	23 m
Persons, max.	Passagiere	12
CE category	CE Kategorie	A



Der Segelplan./ The Sail Plan.

DECKSLAYOUT./ DECK LAYOUT. **CRUISER 55.** SEITENANSICHT./ SIDEVIEW.

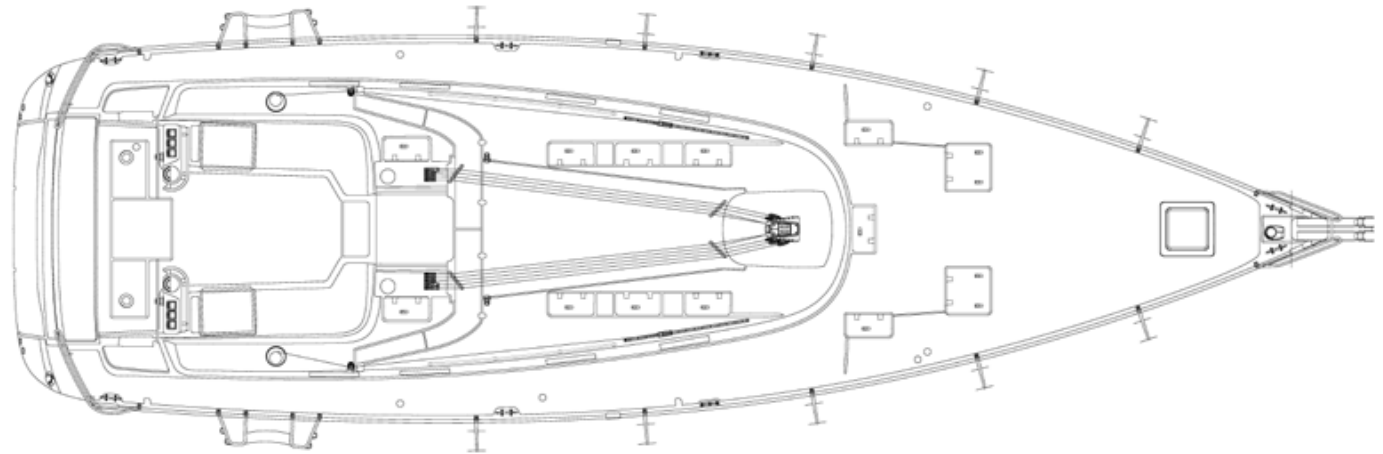

Deckslayout./ Deck layout.



Seitenansicht./Sideview.

BAVARIA./ CRUISER 50.



INTERIEUR./ INTERIOR. CRUISER 50.

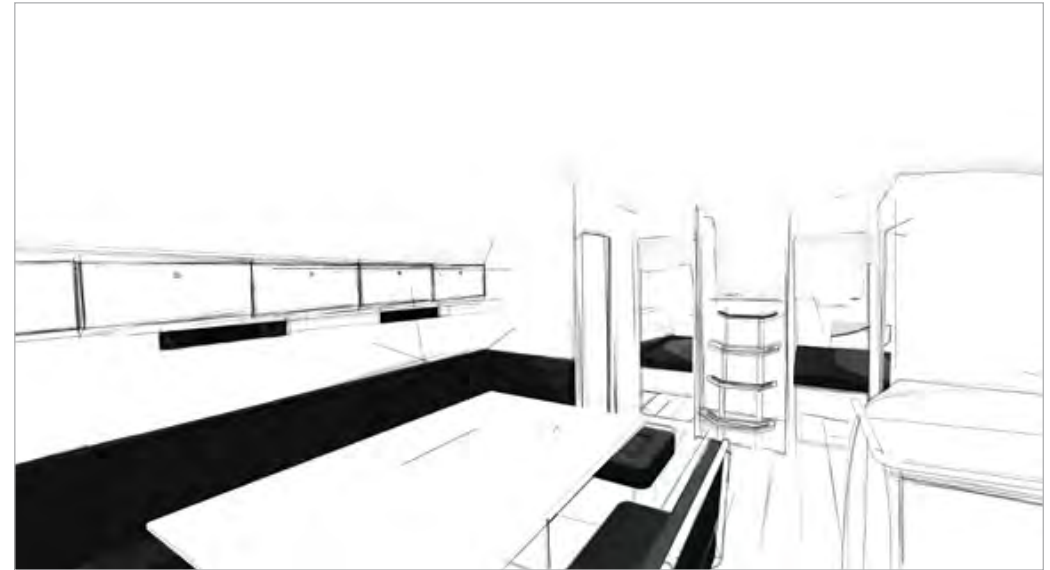

TECHNISCHE DATEN./ TECHNICAL DATA. **CRUISER 50.** SEGELPLAN./ SAILPLAN. DECKSLAYOUT./ DECK LAYOUT.



I = 19,50 m
 J = 6,10 m
 P = 18,52 m
 E = 6,17 m



Length overall	Gesamtlänge	15,57 m
Lenght hull	Rumpflänge	14,99 m
Length waterline	Länge Wasserlinie	13,86 m
Beam overall	Gesamtbreite	4,67 m
Draught Standard	Tiefgang Standard	2,25 m / 1,85 m
Unloaden weight	Leergewicht	14.100 kg
Engine	Motor Volvo Penta	D2-75
Engine Power	Motorleistung	55 kw (75 PS)
Fuel tank	Kraftstofftank	380 l
Water tank	Wassertank	560 l
Cabins	Kabinen	3/4/5
Berths	Kojen	6/8/10
Height in Salon	Stehhöhe im Salon	2,11 m
Main- & Headsail	Großsegel & Rollgenua (Standardausf.)	132/131 m ²
Height above Mast	Masthöhe über Wasserlinie	22,35 m
Persons, max.	Passagiere	12
CE category	CE Kategorie	A-12

Alle Daten vorläufig und ohne Gewähr./All data is subject to change without notice given and warranty.

INTERIEUR./ INTERIOR. CRUISER 50.



3 Kabinen-Version. / 3 Cabin Version.



4 Kabinen-Version A./ 4 Cabin Version A.



4 Kabinen-Version B./ 4 Cabin Version B



5 Kabinen-Version./ 5 Cabin Version.

BAVARIA./ CRUISER 45.







BAVARIA./ CRUISER 45.



INTERIEUR./ INTERIOR. CRUISER 45.



Salon./ Pantry./ Sitzcke./ Vorschiffs-Kabine./ Achterkoje./ Navigationstisch./ Vorschiffbad./ Salon./ Pantry./ Aft Cabin./ Settee./ Vorship./ Aft Bunk./ Navigation Table./Foreship Head.



TECHNISCHE DATEN./ TECHNICAL DATA. **CRUISER 45.** SEGELPLAN./ SAILPLAN. DECKSLAYOUT./ DECK LAYOUT.



Length overall	Gesamtlänge	14,27 m
Lenght hull	Rumpflänge	13,60 m
Length waterline	Länge Wasserlinie	12,74 m
Beam overall	Gesamtbreite	4,35 m
Draught Standard	Tiefgang Standard	2,10 m
Draught Option	Tiefgang Option	1,73 m
Unloaden weight	Leergewicht	12.600 kg
Engine	Motor Volvo Penta	D2 - 55
Engine Power	Motorleistung	41 kw (55 PS)
Fuel tank	Kraftstofftank	210 l
Water tank	Wassertank	360 l Option
Cabins	Kabinen	3/4
Berths	Kojen	6/8
Height in Salon	Stehhöhe im Salon	2,03 m
Main-& Headsail	Großsegel & Rollgenua (Standardausf.)	107 m ²
Height above Mast	Masthöhe über Wasserlinie	20,75 m



INTERIEUR./ INTERIOR. CRUISER 45.



3 Kabinen-Version./ 3 Cabin Version.



4 Kabinen- Version./ 4 Cabin Version

BAVARIA./ CRUISER 40.







BAVARIA./ CRUISER 40.



INTERIEUR./INTERIOR. CRUISER 40.



Eigner-Kabine./ Achter-Kabine./ Bad Achtern./ Pantry./ Sitzecke./ Owners Cabin./ Aft Cabin./ Headroom Aft./ Pantry./ Settee.



TECHNISCHE DATEN./ TECHNICAL DATA. SEGELPLAN./ SAILPLAN. CRUISER 40.

Length overall	Gesamtlänge	12,25 m
Lenght hull	Rumpflänge	11,94 m
Length waterline	Länge Wasserlinie	11,10 m
Beam overall	Gesamtbreite	3,92 m
Draught Standard	Tiefgang Standard	2,05 m
Draught Option	Tiefgang Option	1,65 m
Unloaden weight	Leergewicht	8.680 kg
Engine	Motor Volvo Penta	D1 - 30
Engine Power	Motorleistung	21kw (28 PS)
Fuel tank	Kraftstofftank	210 l
Water tank	Wassertank	210 l + 150 l Option
Cabins	Kabinen	3
Berths	Kojen	6
Height in Salon	Stehhöhe im Salon	1,97 m
Main- & Headsail	Großsegel & Rollgenua (Standardausf.)	81 m ²
Height above Mast	Masthöhe über Wasserlinie	18,68 m

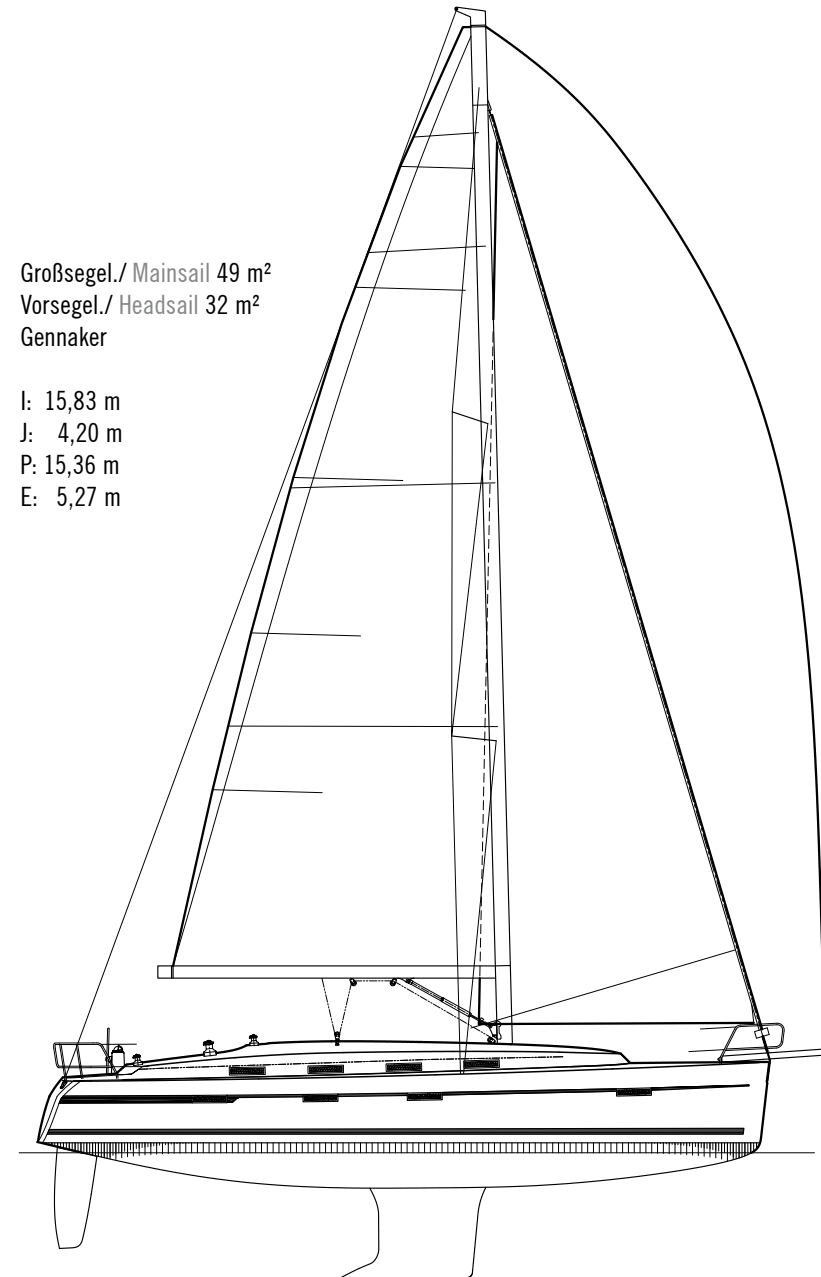

Großsegel./ Mainsail 49 m²
 Vorsegel./ Headsail 32 m²
 Gennaker

I: 15,83 m
 J: 4,20 m
 P: 15,36 m
 E: 5,27 m

Der Segelplan./ The Sail Plan.



DECKSLAYOUT./ DECK LAYOUT. **CRUISER 40.** INTERIEUR./ INTERIOR.



Decks layout./ Deck layout.



3 Kabinen./ 3 cabins..

TECHNISCHE DATEN./ TECHNICAL DATA. CRUISER 40 S.



Length overall	Gesamtlänge	11,99 m
Lenght hull	Rumpflänge	11,99 m
Length waterline	Länge Wasserlinie	10,69 m
Beam overall	Gesamtbreite	3,96 m
Draught Standard	Tiefgang Standard	2,35 m
Draught Option	Tiefgang Option	1,65 m
Unloaden weight	Leergewicht	8.115 kg
Engine	Motor Volvo Penta	D1 - 30 / D2-40 opt.
Engine Power	Motorleistung	21kw (29 PS)
Fuel tank	Kraftstofftank	210 l
Water tank	Wassertank	210 l + 150 l Option
Cabins	Kabinen	3
Berths	Kojen	6
Height in Salon	Stehhöhe im Salon	1,97 m
Main- & Headsail	Großsegel & Rollgenua (Standardausf.)	91 m ²
Height above Mast	Masthöhe über Wasserlinie	19,20 m

Mit der Sportversion der CR 40 steht Ihnen eine neue Yacht zur Verfügung, die nicht nur den gewohnten Komfort eines Cruisers bietet, sondern auch die besonderen Eigenschaften eines Cruiser Racers besitzt.

Die von Farr Yacht Design weiterentwickelte 40 S ist mit einem längeren Kiel, einem Performance Rigg, Regattabeschlägen, Carbonspibaum, Composite Steuerrädern und vielen weiteren Details ausgestattet und optimiert worden.

Dieser Yacht vertrauen auch die Profis - die 40 S ist offizieller Ausstatter der Match Race World-cups Stops in Deutschland.

With the new Sports-Version of the CR 40, a new yacht has been made available to you with the well-known comfort of the existing CRUISER line, but with the addition of the special features of a Cruiser Racer.

The 40.S was designed in cooperation with Farr Yacht Design and equipped with a longer keel, a performance rigg, regatta fittings, carbon-spi-boom, composite steering wheels and many more details.

Even professionals rely on this type of yacht – the 40.S is the official yacht for the Match Race Worldcup Stop-over in Germany.

SEGELPLAN./ SAILPLAN. CRUISER 40 S.

Großsegel./ Mainsail 49 m²
Vorsegel./ Headsail 32 m²
Gennaker

I: 15,83 m
J: 4,22 m
P: 15,80 m
E: 5,66 m

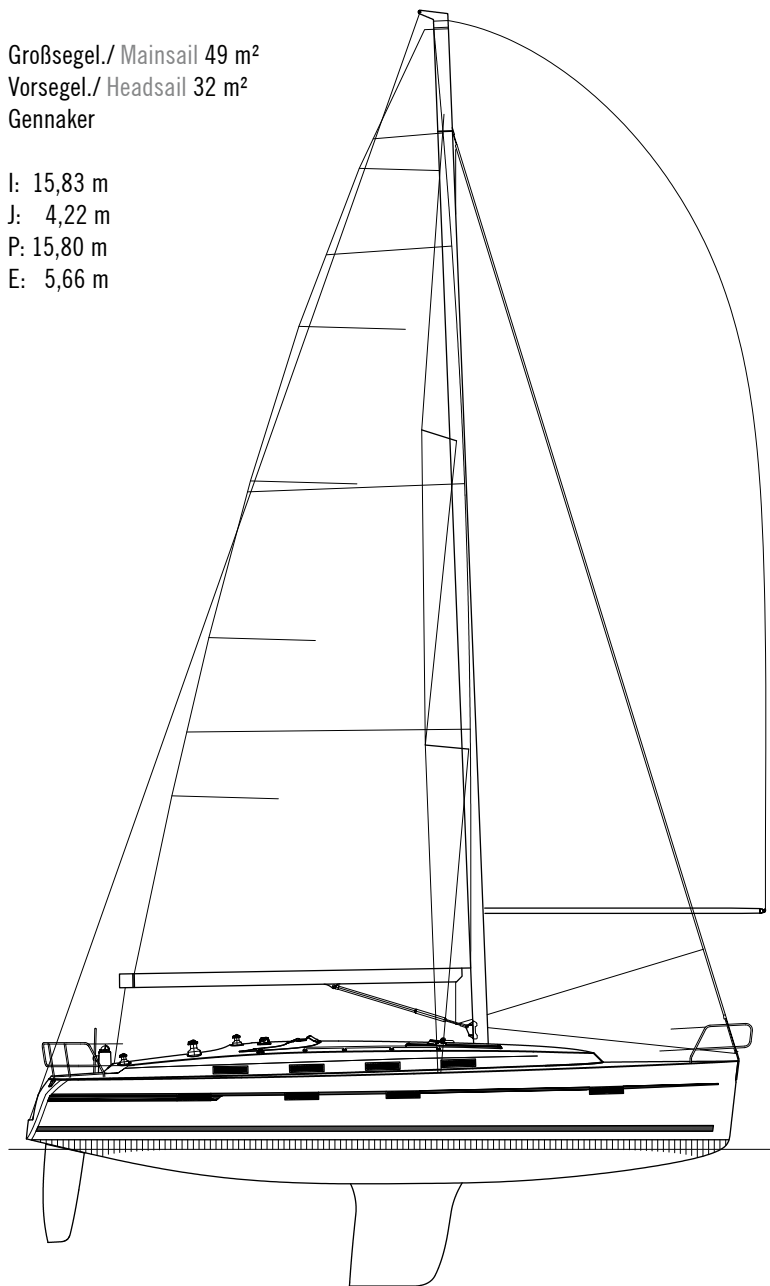

BAVARIA./ CRUISER 36.







BAVARIA./ CRUISER 36.



INTERIEUR./ INTERIOR. CRUISER 36.



Salon./ Navigationstisch eingeklappt./
Kleiderschrank in der Vorschiffs-Kabine./ Flaschenregal im Salon./
ausgezogener Navigationstisch./ Vorschiffs-Kabine./
Salon./ Navigation table folded in./Wardrobe Foreship./
Bottle shelf./ Navigation table flipped out./ Foreship Cabin.



TECHNISCHE DATEN./ TECHNICAL DATA. CRUISER 36.

SEGELPLAN./ SAILPLAN.

Length overall	Gesamtlänge	11,30 m
Lenght hull	Rumpflänge	10,90 m
Length waterline	Länge Wasserlinie	9,90 m
Beam overall	Gesamtbreite	3,67 m
Draught Standard	Tiefgang Standard	1,95 m
Draught Option	Tiefgang Option	1,63 m
Unloaden weight	Leergewicht	7.000 kg
Engine	Motor Volvo Penta	D1 - 20
Engine Power	Motorleistung	13 PS
Fuel tank	Kraftstofftank	150 l
Water tank	Wassertank	210 l + 150 l Option
Cabins	Kabinen	2
Berths	Kojen	4
Height in Salon	Stehhöhe im Salon	1,95 m
Main- & Headsail	Großsegel & Rollgenua (Standardausf.)	69 m ²
Height above Mast	Masthöhe über Wasserlinie	16,95 m

Großsegel./Mainsail 42 m²
 Vorsegel./Headsail 27 m²
 Gennaker

I: 14,10 m
 E: 5,10 m
 P: 13,62 m
 J: 3,73 m

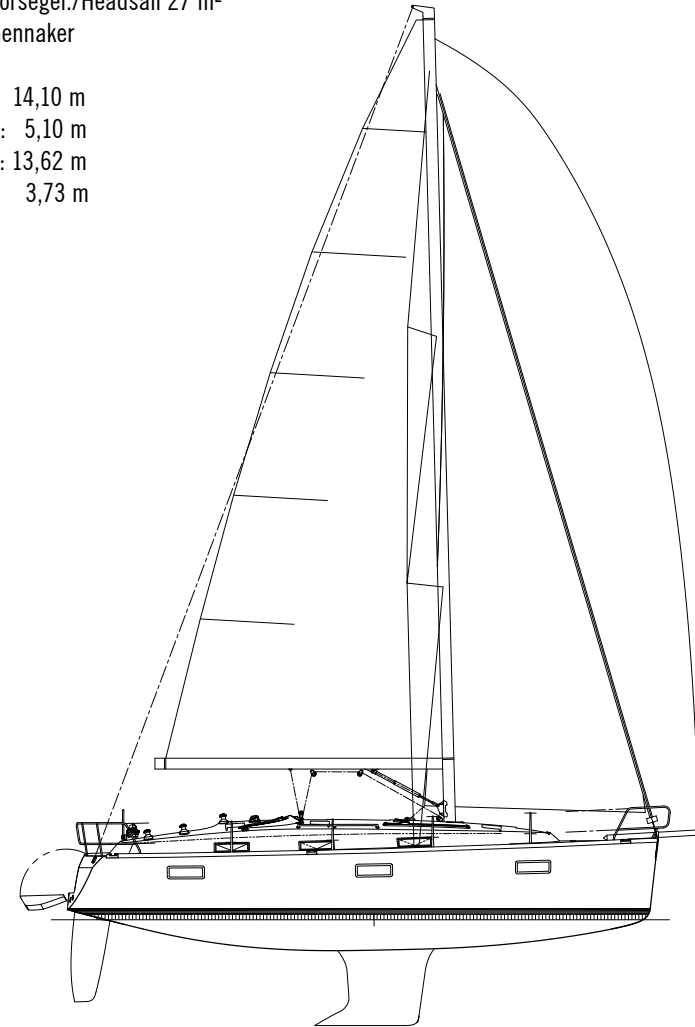

Der Segelplan./ The Sail Plan.



DECKSLAYOUT./ DECK LAYOUT. **CRUISER 36.** INTERIEUR./ INTERIOR.



Das Decks layout./The deck layout.



Das 2-Kabinen-Interieur./The 2-cabins Interior.



Das 3-Kabinen-Interieur./The 3-cabins Interior.

BAVARIA./ CRUISER 32.







BAVARIA./ CRUISER 32.



INTERIEUR./ INTERIOR. CRUISER 32.



Bad./ Vorschiffskabine./ Pantry./ Salon./ Achterkabine./ Head Room./ Foreship Cabin./ Pantry./ Aft Cabin.



TECHNISCHE DATEN./ TECHNICAL DATA. CRUISER 32.

SEGELPLAN./ SAILPLAN.

Length overall	Gesamtlänge	9,99 m
Lenght hull	Rumpflänge	9,75 m
Length waterline	Länge Wasserlinie	8,85 m
Beam overall	Gesamtbreite	3,42 m
Draught Standard	Tiefgang Standard	1,95 m
Draught Option	Tiefgang Option	1,50 m
Unloaden weight	Leergewicht	5.200 kg
Engine	Motor Volvo Penta	D1 - 20
Engine Power	Motorleistung	14 kw (18 PS)
Fuel tank	Kraftstofftank	150 l
Water tank	Wassertank	150 l
Cabins	Kabinen	2
Berths	Kojen	4
Height in Salon	Stehhöhe im Salon	1,84 m
Main- & Headsail	Großsegel & Rollgenau (Standardausf.)	51 m ²
Height above Mast	Masthöhe über Wasserlinie	14,80 m

Großsegel./ Mainsail 42 m²
 Vorsegel./ Headsail 27 m²
 Gennaker

I: 14,10 m
 E: 5,10 m
 P: 13,62 m
 J: 3,73 m

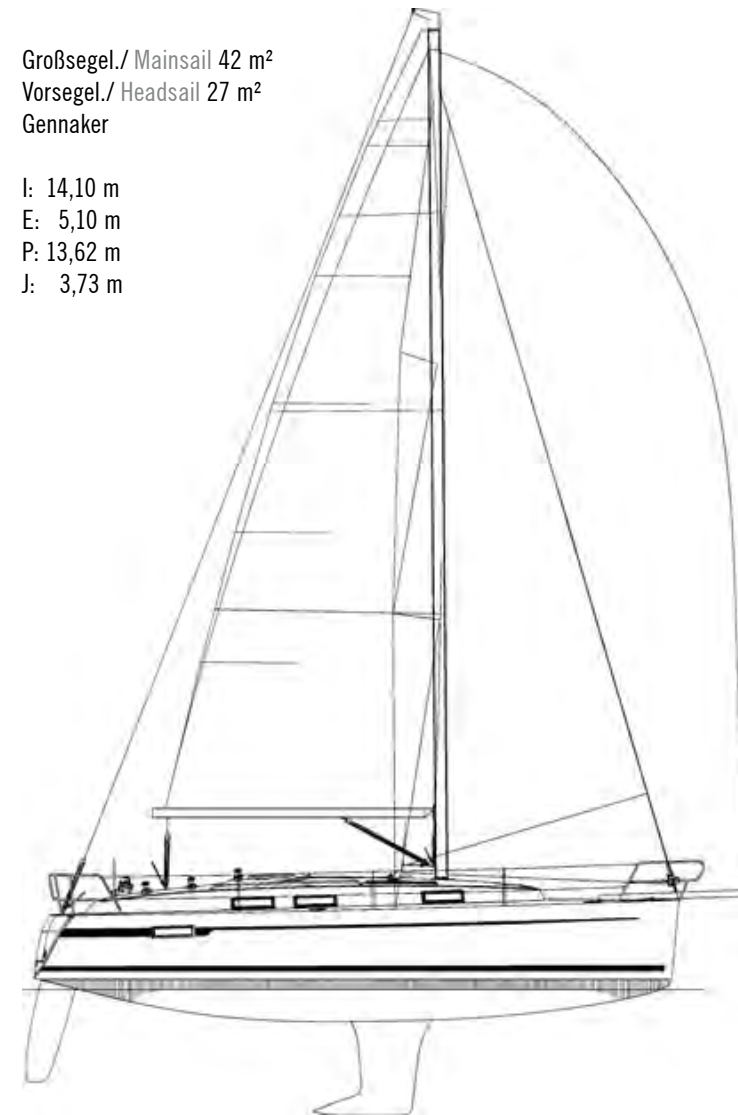

Der Segelplan./The Sail Plan.

DECKSLAYOUT./ DECK LAYOUT. **CRUISER 32.** INTERIUER./ INTERIOR.



Deckslayout./ The deck layout.



Das Interieur./The Interior.



DIE WERFT./ THE SHIPYARD. BAVARIA./ ERFAHRUNG UND INNOVATION.

Die BAVARIA-Werft ist seit über 30 Jahren weltweit führend in der Serienproduktion von Yachten. Durch diese langjährige Erfahrung entwickelte unser Unternehmen den effizientesten Produktionsablauf in dieser Branche.

Alle Yachten werden ausschließlich auf Bestellung angefertigt. Schwerpunkt ist hier die Kombination von traditionellem und modernstem Boots- und Yachtbau. Automation und fachlich kompetente Mitarbeiter arbeiten Hand in Hand und sorgen dafür, dass Ihre persönlichen Wünsche und Pläne Wirklichkeit werden.

So tätigen wir große Investitionen in Hinblick auf die Verarbeitung bester und moderner Materialien. Unsere hausinterne Konstruktions- und Entwicklungsabteilung erhöht die Sicherheit unserer Yachten durch eine komplexe Konstruktion und Struktur der Schiffe, so dass eine höhere Belastbarkeit erreicht wird, als gefordert. Aber auch im Inneren der Yachten sorgen unsere In-House Designer für das persönliche Ambiente. Vor Auslieferung eines jeden Schiffes erfolgt eine gewissenhafte und komplexe Prüfung durch unser eigenes Qualitätsmanagement-Team. Insgesamt sind 1.300 Hände am Produktionsprozess beteiligt.

Präzision und Qualität ist die höchste Maxime der BAVARIA-Werft. Schon bei der Planung arbeitet unser erfahrenes Konstruktions-Team mit modernster 3D-Technik. Eine umfangreiche Qualitätskontrolle aller Zulieferteile und Materialien erfolgt schon bei der Anlieferung. Die Vorproduktion der einzelnen Baugruppen und Komponenten wird rechnergestützt gesteuert (CNC), so dass ein optimaler Produktionsprozess gewährleistet ist. Die automatische Lackierstraße unserer Tischlerei verfügt über eine moderne UV-Trocknung. Ferner stehen automatisch klimatisierte Laminier- und Temperräume zur Gewährleistung eines optimalen Ergebnisses zur Verfügung. Neben dem Einsatz hochmoderner Technologie legt BAVARIA großen Wert auf steigende Handwerksqualität. Darauf sind wir stolz und unterlegen uns freiwillig den strengen Zertifizierungsverfahren durch den Germanischen Lloyd.

Alles aus einer Hand – die Herstellung der Schiffe erfolgt ausschließlich in unserer Werft in Giebelstadt auf einer Produktionsstrecke von insgesamt 6 km – vom ersten Montageschritt bis zur Fertigstellung.

The BAVARIA shipyard has been the worldwide leader for series production based yachts for over 30 years. Thanks to the long lasting experience, our company has developed one of the most efficient production lines within the market.

All yachts are solely built based on order. The main focus lies upon the combination of traditional and modern yacht building. Automation and highly-skilled workmen work hand in hand to make your personal plans and dreams come true. We focus specifically on investing in the best and most up to date materials. Our internal construction and development department ensures the maximum on safety for your yachts through a complex construction and structure of the boats to gain high capacities. Our in-house designers care for a more personal ambience of the interior onboard. Before each boat is delivered to the customer, the yacht undergoes a thorough and complex testing system done by our quality management team. More than 1.300 hands are involved in the production process.

Precision and quality are both the highest maxim of the BAVARIA shipyard. Quality starts with the first sketch: Even at the beginning of the planning stages, our experienced construction team uses the most modern 3D-technology.

A comprehensive quality control of all parts and material is already done straight after the product deliveries. The preproduction of the individual sub assembly and components is PC-controlled (CNC) to ensure an optimized production process. The automatically-run coating line of our carpentry has a modern UV drying application. Furthermore, there are many automatically-climatised coating and temper rooms to guarantee the best possible results. Along with the deployment of highly-modern technology, BAVARIA pays special attention to steadily improved craftsmanship quality. We are very proud and put ourselves under the strict certification process done by the Germanischer Lloyd (GL).

We are a one-stop shipyard – the boats are purely and only made in our shipyard in Giebelstadt on a production line measuring a total of six km – from the first step to the final completion.





BAVARIA. PARTNER./ PARTNERS



Um ein Premium Produkt herzustellen benötigt man die besten Partner im Boot. Durch unsere enge Zusammenarbeit mit den Spezialisten und Marktführern im Ausstattungsbereich, können Sie sicher sein, ein auf Ihre individuellen Ansprüche rundum perfekt abgestimmtes Produkt zu erhalten.

In order to produce a premium product you need the best partners onboard. Thanks to our close cooperation with specialists and market leaders of the equipment sector, you can be assured to receive a perfectly rounded up product.

GARMIN

 **MARX**

**NAUTI
SATTLER**

LIROS

**ELVSTROM
SAILS**

**VOLVO
PENTA**

 **SELDÉN**

WINNER
Reversible Winches





Bavaria Yachtbau GmbH, Bavariastraße 1, D-97232 Giebelstadt, Tel. +49 9334 942-0, Fax +49 9334 942-1160, www.bavaria-yachtbau.com, info@bavaria-yachtbau.com

Die abgebildeten Yachten sind teilweise mit aufpreispflichtigen Extras ausgestattet. Angaben über die Beschaffenheit basieren auf Konstruktionszeichnungen und können von der tatsächlichen Ausführung abweichen. Dieser Katalog ist kein Vertragsbestandteil. Alle Beschreibungen, Darstellungen etc. dienen lediglich der Veranschaulichung.

The illustrated yachts are partially equipped with optional features only available at extra cost. Information on the configuration is based on design drawings and may differ from the actual version. This catalogue is not part of the contract. All descriptions, illustrations etc. solely serve as demonstration.

