

Spinnaker Pole heel Lift System

Fitting and Assembly

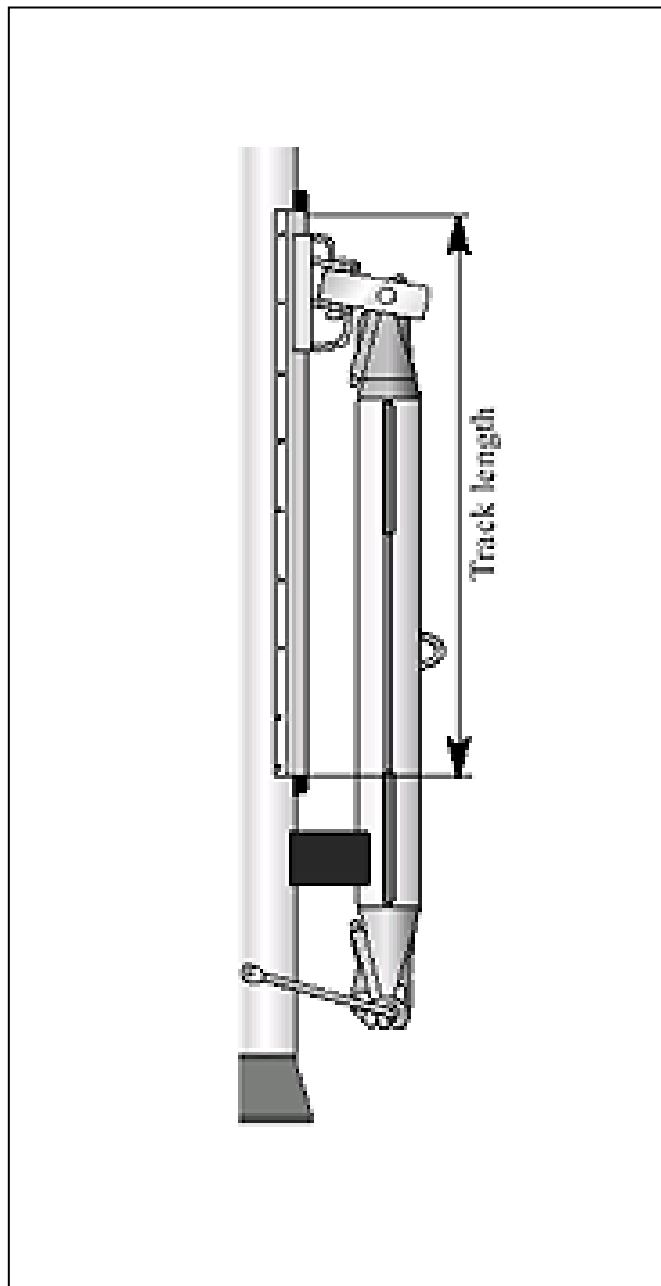

General

This instruction describes fitting single spinnaker pole tracks.
Track types: "RCB 30W" and "25mm".

Assembly - single track

1. Turn the mast with the A-line facing up.
2. Mark the height measure (Ref. point) and draw a line perpendicular to the A-line through the mark.
3. Place the track upper end in level with the Ref. point, centred over the A-line and fix it with packing tape. (Do not cover any predrilled holes). If the track passes cast aluminium spreader brackets, see section "Assembly—single track with bedding" below before proceeding.
4. Drill the uppermost hole-pair Ø 4,9 mm or Ø 6,5 mm depending on type of rivet. Place rivets in the holes to keep the track in position.
5. Continue to drill every four or five hole-pairs and place rivets in the holes along the way. Make sure the track does not slip out of position.
6. When the end of the track is reached, drill the remaining holes. The inserted rivets will keep the track in position.
7. Remove the track and clean with the air-gun.
8. Grind the track ends with a fine file.

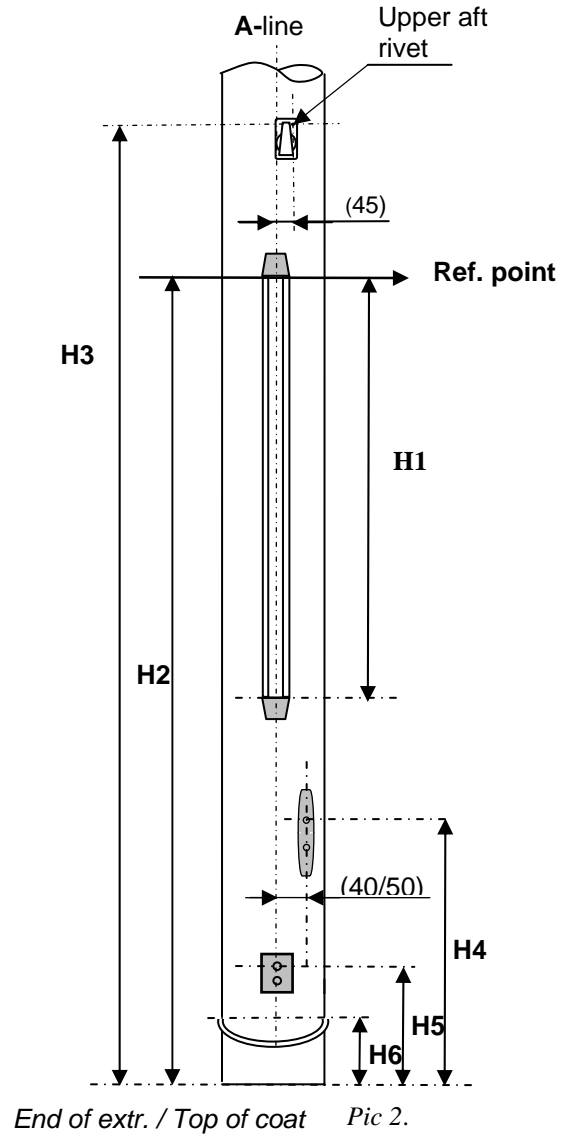
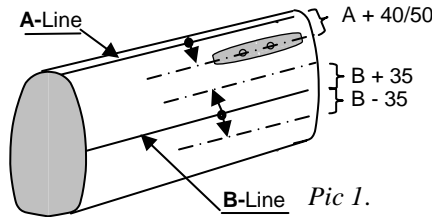

| (T)= Triple fastening | | | | | | |
|--------------------------|-----------------|------------|-------------|-------------|---------|------------|
| (D)= Double fastening | H1 | H2 | H3 | H4 | H5 | H6 |
| Boat | Length of track | Ref. point | Block | Cleat | Suppot | Hoop |
| Bavaria-30+31 Sport | 2400 | 3250 | 3550 / A+45 | 600 / A+40 | 350 A+0 | 200 / B+0 |
| Bavaria-30+31 Furlin | 2400 | 3250 | 3550 / A+45 | 600 / A+40 | 350 A+0 | 200 / B-10 |
| Bavaria-33+34 Sport (D) | 3400 | 4000 | 4300 / A+45 | 600 / A+40 | 350 A+0 | 200 / B+0 |
| Bavaria-33+34 Furlin (D) | 3400 | 4000 | 4300 / A+45 | 600 / A+40 | 350 A+0 | 200 / B-10 |
| Bavaria-37 Sport | 3400 | 4140 | 4440 / A+45 | 700 / A+50 | 350 A+0 | 200 / B+0 |
| Bavaria-37 Furlin | 3400 | 4140 | 4440 / A+45 | 700 / A+50 | 350 A+0 | 200 / B-10 |
| Bavaria-39 Sport (D) | 3400 | 4700 | 5000 / A+45 | 1000 / A+50 | 350 A+0 | 200 / B+35 |
| Bavaria-39 Furlin (D) | 3400 | 4700 | 5000 / A+45 | 1000 / A+50 | 350 A+0 | 200 / B+35 |
| Bavaria-42 Sport (D) | 4800 | 5600 | 5900 / A+45 | 600 / A+50 | 350 A+0 | 200 / B+35 |
| Bavaria-42 Furlin (D) | 4800 | 5600 | 5900 / A+45 | 600 / A+50 | 350 A+0 | 200 / B+35 |
| Bavaria-46 Sport (D) | 4800 | 6200 | 6500 / A+45 | 1000 / A+50 | 350 A+0 | 200 / B+80 |
| Bavaria-46 Furlin (D) | 4800 | 6200 | 6500 / A+45 | 1000 / A+50 | 350 A+0 | 200 / B+50 |
| Bavaria-50 Sport (T) | 4800 | 6550 | 6850 / A+45 | 1200 / A+50 | 350 A+0 | 200 / B+80 |
| Bavaria-50 Furlin (T) | 4800 | 6550 | 6850 / A+45 | 1200 / A+50 | 350 A+0 | 200 / B+80 |
| Bavaria-40 V Furlin (D) | 3400 | 4250 | 4550 / A+45 | 1000 / A+50 | 350 A+0 | 200 / B+50 |
| Bavaria-40 V Sport (D) | 3400 | 4250 | 4550 / A+45 | 1000 / A+50 | 350 A+0 | 200 / B+50 |
| Bavaria-44 V Furlin (T) | 4800 | 5000 | 5300 / A+45 | 1000 / A+50 | 350 A+0 | 200 / B+50 |
| Bavaria-44 V Sport (T) | 4800 | 5000 | 5300 / A+45 | 1000 / A+50 | 350 A+0 | 200 / B+50 |
| Bavaria-50 V Furlin (D) | 4800 | 6100 | 6400 / A+45 | 1200 / A+50 | 350 A+0 | 200 / A+0 |
| Bavaria-50 V Sport (D) | 4800 | 6100 | 6400 / A+45 | 1200 / A+50 | 350 A+0 | 200 / A+0 |

9. Re-position the track and fasten with rivets.
10. Punch out all mandrel heads.
11. Place the end stops and mark the holes with a pencil.
12. Drill and rivet the upper end stop. If track 25mm/R34 is used, place a washer (164-002) under the end stop. Drill the lower end stop holes (RCB 30W: with buffer 520-516) to $\text{Ø} 4,9$ mm and tap M6. Fix the lower end stop with M6 screws with the car on the track. Use Schneidmittel or similar to lubricate the threads. If track 25mm/R34 is used, place a washer (164-002) under the end stop.

Assembly - single tracks with bedding (RCB 30W only)

1. Turn the mast with the A-line facing up.
2. Mark the height measure (Ref. point) and draw a line perpendicular to the A-line through the mark.
3. Place the track in level with the Ref. point, centred over the A-line.. Proceed with "Cut-out for spreader bracket" below.
4. Grind the edges.
5. Place the track upper edge in level with the height measure, (Ref. point) centred over the A-line and located over the cut out for spreader bracket.
6. Measure out the length of the bedding and place it under the track on both sides of spreader bracket. See pic 3.
7. Grind the bedding ends with a fine file.
8. Fix the track and bedding with packing tape (hard), centred over the A-line. Do not cover any predrilled holes.
9. Drill the uppermost hole-pair with $\text{Ø} 6,5$ mm. Place rivets in the holes to keep the track and bedding in position.
10. Continue to drill every four or five hole-pairs and place rivets in the holes along the way. Make sure the track and bedding does not slip out of position.
11. When the end of the track is reached, drill the remaining holes. The inserted rivets will keep the track in position, remove the packing tape.
12. Loosen the track and bedding, blow clean from burrs.
13. Fit the track with bedding, insert the rivets and fasten it.
14. Punch out the mandrel heads and
15. Place the end stops with buffers and mark the holes with a pencil.
16. Drill $\text{Ø} 6,5$ mm and rivet the upper end stop with buffer (520-516) see pic 4. Put the lower end stop with buffer (520-516) in position, drill the lower end stop holes to $\text{Ø} 4,9$ mm and tap M6.
17. Slide the car onto the track and fix the lower end stop (with buffer) with M6 screws. Use schneidmittel or similar to lubricate the threads.



Pic 3.



Pic 4.

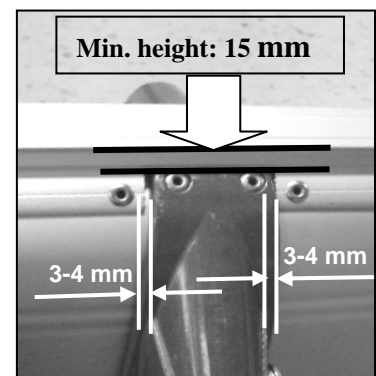

Pic 5

Cut-out for spreader bracket (RCB 30W only)

- Mark for a cut-out in the track, 3-4 mm each side of the spreader bracket and leave min. 15mm of track height to ensure that the cars can pass with clearance. See pic 5.
- Make the cut out and grind all edges.

Double fastening (reinforced track)

If double fastening is specified, drill and rivet between the original rivets, up until 3000 mm from end of extrusion / top of coat. See pic. 6. (No double fastening is required above 3000 mm from end of extrusion / top of coat.)

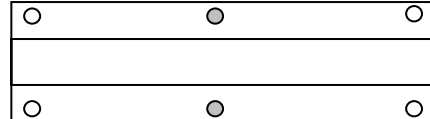

Pic 6

Triple fastening (reinforced track)

If triple fastening is specified, drill and rivet two rivets between the original rivets, up until 3000 mm from end of extrusion / top of coat. See pic. 7. (No triple fastening is required above 3000 mm from end of extrusion / top of coat.)

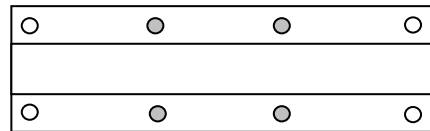

Pic 7

Assembly - cleat

1. Mark the height **H4** and the side (A / 40 mm or 50mm, see table page 1) measurement for the cleat.
2. Use the cleat as a template and mark the lower hole.
3. Drill both holes $\varnothing 4,9$ mm and enlarge to $\varnothing 6,5$ mm.
4. Fasten the cleat with the long rivets (use rivet pistol with long nozzle).
5. Punch out the mandrel heads.

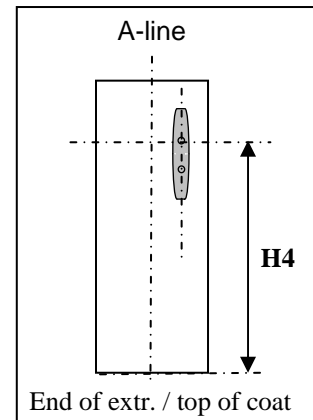

Pic 8

Assembly - Hoop and support

508-090-02 (Hoop + support):



Hoop

1. Mark **H6**, the location of the hoop rivet holes and the support upper hole acc. to table above. Support on the A-line and Hoop offset B-line (-B, B or +B).
2. Drill the holes for the hoop $\varnothing 6,5$ mm.
3. Add nylon washers between hoop and mast and fix with rivets. **Note:** Hoop ends may need to be adjusted to fit mast section, before it is fitted. Clamp the hoop in a vice and bend carefully, see pic 9.
4. Punch out the mandrel heads.

Support

5. Use washer 164-408 and mark the two holes with a pencil. (Upper hole on height measure **H5**.)

6. Drill $\varnothing 4,9$ mm in the marks, enlarge to $\varnothing 6,8$ mm and tap M8.
7. Add washer 164-408 into support and insert screws. (Screws resting on washer). Add Schneidmittel or similar on the threads and fasten the support.

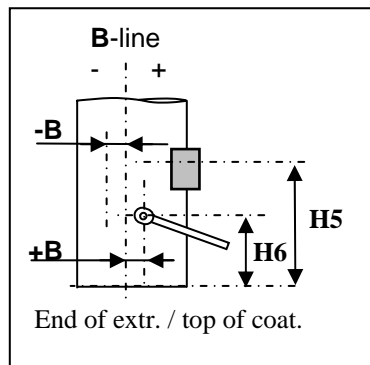

Pic 9

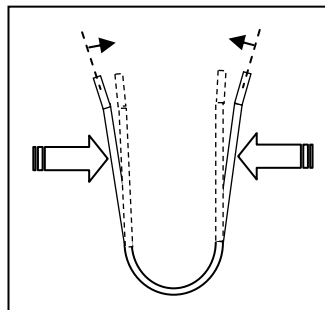

Pic 10

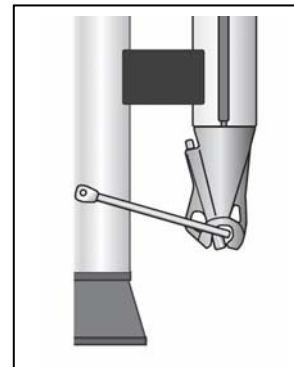

Pic 11

Assembly – Hoop/bracket and support

508-212-02 (Hoop/bracket + support):

Before assembly, add insulating lacquer on hoop/bracket back surface and let dry.

Adjust bracket to fit radius to mast, see point 1 below.

1. Position support/bracket with the upper holes on the marked height line. Mark the holes with a pencil, drill $\varnothing 6,5$ mm and fasten with rivets. When fitted on larger masts the bracket radius will not fit. To adjust the radius, drill the two middle holes $\varnothing 4,9$ mm, tap M6 and fit with temporary M6 screws. Drill and fit the outer rivets. Remove the temporary screws, drill $\varnothing 6,5$ mm and replace the screws with rivets. If necessary, the webs can be bent back slightly using a large adjustable spanner.
2. Punch out the mandrel heads.
3. Fit hoop to bracket. (Washers to be fitted between bracket and hoop.)
4. To fit the support, see above, section *Assembly - Hoop and support (508-090-02)*.

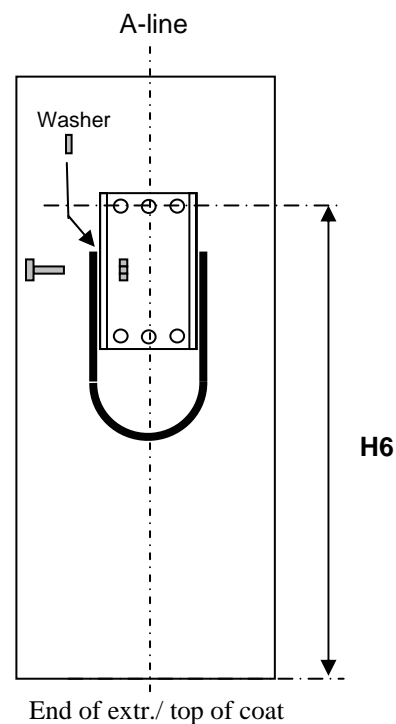

Pic 12.

Check points

- When joining two tracks (Bav 50), fit the shorter track piece on top and be sure to fit the tracks exactly in line. Grind the edges in the join gently.

DINGHIESKEELBOATSYACHTS

Seldén Mast AB, Sweden
 Tel +46 (0)31 69 69 00
 Fax +46 (0)31 29 71 37
 e-mail info@seldenmast.com

Seldén Mast Limited, UK
 Tel +44 (0) 1329 504000
 Fax +44 (0) 1329 504049
 e-mail info@seldenmast.co.uk

Seldén Mast Inc., USA
 Tel +1 843-760-6278
 Fax +1 843-760-1220
 e-mail info@seldenus.com

Seldén Mast A/S, DK
 Tel +45 39 18 44 00
 Fax +45 39 27 17 00
 e-mail info@seldenmast.dk

Seldén Mid Europe B.V., NL
 Tel +31 (0) 111-698 120
 Fax +31 (0) 111-698 130
 e-mail info@seldenmast.nl

Seldén Mast SAS, FR
 Tel +33 (0) 251 362 110
 Fax +33 (0) 251 362 185
 e-mail info@seldenmast.fr

www.seldenmast.com

Dealer:

The Seldén Group is the world's leading manufacturer of masts and rigging systems in carbon and aluminium for dinghies, keelboats and yachts. The Group consists of Seldén Mast AB in Sweden, Seldén Mast A/S in Denmark, Seldén Mast Ltd in the UK, Seldén Mid Europe B.V. in the Netherlands, Seldén Mast SAS in France and Seldén Mast Inc in the USA.

Our well known brands are Seldén and Furlex. The worldwide success of Furlex has enabled us to build a network of over 750 authorised dealers covering the world's marine markets. So wherever you sail, you can be sure of fast access to our service, spare parts and know-how.

