

Spinnakerbom-byggsats, "end-for-end"

Monteringsinstruktion for spinnakerbommar

Verktyg som behövs:

Bågfil

Borrmakin

Borr Ø 4

1. Beräkna längden på röret enligt tabell 1 och fig. 1.
2. Markera längden på röret.
3. Kapa röret i rätt längd. Det går lätt att få ett rakt snitt om man ritar efter ett papper som viks runt röret (fig. 2).
4. Kapa röret och grada snittytorna.
5. För in slitslisterna.
6. Stoppa i ändbeslagen i röret.
7. Markera hålen för skruvarna enligt PS735, för spinnaker beslag 534-865 eller PS736 för spinnaker beslag 534-854.
8. Borra med borr Ø 4 enligt markeringarna.
9. Skruva fast beslagen.
10. För slitlisterna ut mot ändbeslagen och lås dem genom att stuka spårets kanter. Det går utmärkt med en skruvmejsel (fig. 3).
11. Mät ut mitten, borra Ø 4 mm och skruva fast liftbygeln och ev. nedhalsbygeln. OBS, liftbygglarna kan ersättas av hanfötter, se tabell 2.

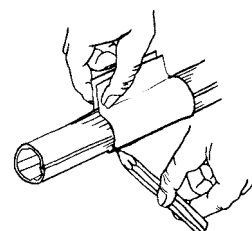
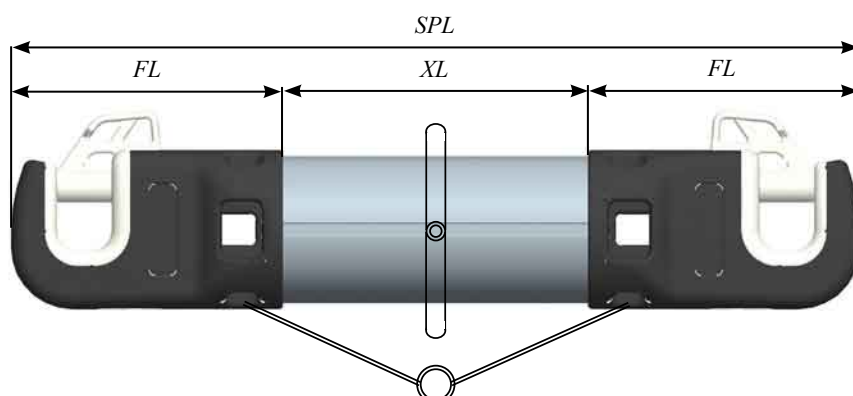

Fig. 2

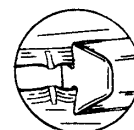

Fig. 3

Tabell. 1

Profil	SPL - FL = XL
48/48	SPL - (90 + 90) = rörlängd
60/60	SPL - (110 + 110) = rörlängd
72/72	SPL - (90 + 90) = rörlängd
84/84	SPL - (110 + 110) = rörlängd
96/96	SPL - (130 + 130) = rörlängd

Tabell. 2

Hanfot		
Art. nr.	Lin dia.	Max SPL
613-051-04	Ø 4	3250
613-051-05		4500
613-051-06		5500

Spinnaker pole kit, end-for-end

Assembly instructions for kit spinnaker poles

Tool required:

Hack saw

Drill

Drill bit Ø 4

1. Calculate the length of extrusion XL, use table 1 and fig. 1
2. Mark the calculated length on the extrusion, it is easy to mark a straight and square cut if you draw along a paper folded around the extrusion (fig. 2).
3. Cut the extrusion and chamfer the edges.
4. Side in the plastic pole savers.
5. Insert the pole ends into the extrusion.
6. Mark the holes for the screw according PS735 pole end 534-865 or PS736 for pole ends 534-854
7. Drill Ø 4 holes thru the extrusion and pole ends.
8. Fit the pole end with the screws.
9. Push the pole savers against the pole end and lock them in position by deforming the tracks with a screw driver (fig 3).
10. Mark the midpoint of the extrusion drill two holes for the lift eye. Fit the lift eyes. **NOTE:** The lift eyes can be replace with bridles, see table 2.

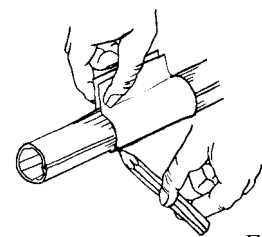
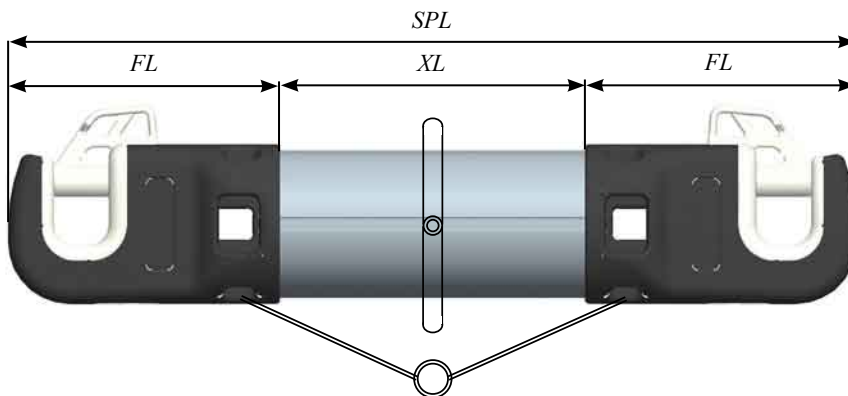

Fig. 2

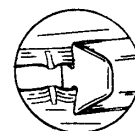

Fig. 3

Table. 1

Extrusion	SPL - FL = XL
48/48	SPL - (90 + 90) = extrusion length
60/60	SPL - (110 + 110) = extrusion length
72/72	SPL - (90 + 90) = extrusion length
84/84	SPL - (110 + 110) = extrusion length
96/96	SPL - (130 + 130) = extrusion length

Table. 2

Bridle		
Part no.	Line dia.	Max SPL
613-051-04	Ø 4	3250
613-051-05		4500
613-051-06		5500

Spinnakerbaum Bausatz A

Montageanleitung für Spinnakerbaum Bausätze

Folgendes Werkzeug wird benötigt:

Metallsäge,

Bohrmaschine und Bohrer Ø 4 mm

Schraubendreher und Hammer

1. Ermitteln Sie, gemäß der unten stehenden Zeichnung (Abb.1) und der Tabelle 1, die erforderliche Länge (XL) des Profils.
2. Markieren Sie die ermittelte Länge auf dem Profil. Um eine gerade Markierung zu erhalten, benutzen Sie ein Stück Papier wie in Abb. 2 dargestellt.
3. Sägen Sie das Profil auf die erforderliche Länge und entgraten Sie die Schnittstelle.
4. Schieben Sie die Schutzleisten in die entsprechenden Nuten.
5. Setzen Sie die Endbeschläge auf die Profilenden.
6. Markieren Sie die Bohrlöcher für die Schrauben. Nehmen Sie die Zeichnung PS735 für Endbeschlag 534-865 oder PS736 für Endbeschlag 534-854 zur Hilfe.
7. Bohren Sie die Bohrlöcher Ø 4mm durch das Profil und die Endbeschläge.
8. Montieren Sie die Endbeschläge mit den Schrauben.
9. Schieben Sie die Schutzleisten an die Endbeschläge und sichern Sie die Leisten durch das Eindrücken der Nuten an den inneren Enden der Leisten. (Abb. 3).
10. Markieren Sie die Mitte des Profils in den Nuten und bohren Sie zwei Löcher für die Lift-Augen-Bügel.
ACHTUNG: Alternativ können die Bügel gegen einen Hahnepot getauscht werden, siehe Tab. 2.



Abb. 2



Abb. 3

Tabelle. 1

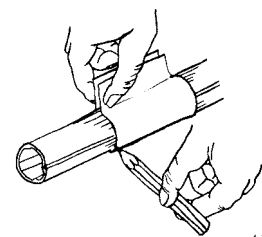
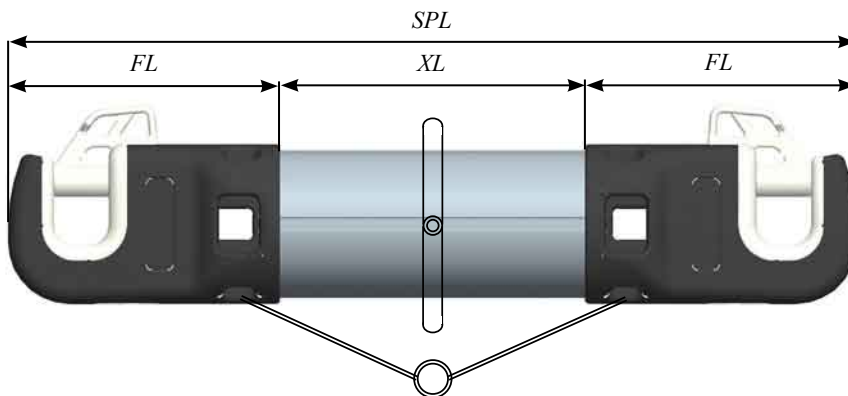
Profil	SPL - FL = XL
48/48	SPL - (90 + 90) = Profil Länge
60/60	SPL - (110 + 110) = Profil Länge
72/72	SPL - (90 + 90) = Profil Länge
84/84	SPL - (110 + 110) = Profil Länge
96/96	SPL - (130 + 130) = Profil Länge

Tabelle. 2

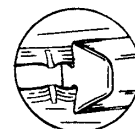
Hahnepot		
Art.-Nr.	Draht Ø	Max SPL
613-051-04	Ø 4	3250
613-051-05		4500
613-051-06		5500

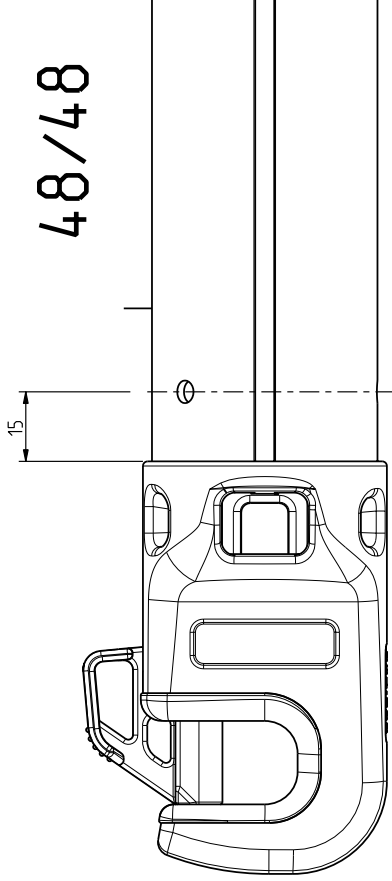

48/48

D (HOLE DIAMETER)	
RIVET	SCREW (SPINN. POLE KIT)
Ø4.9	Ø4

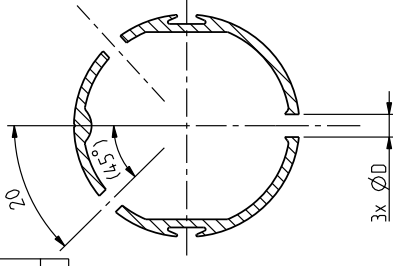

60/60

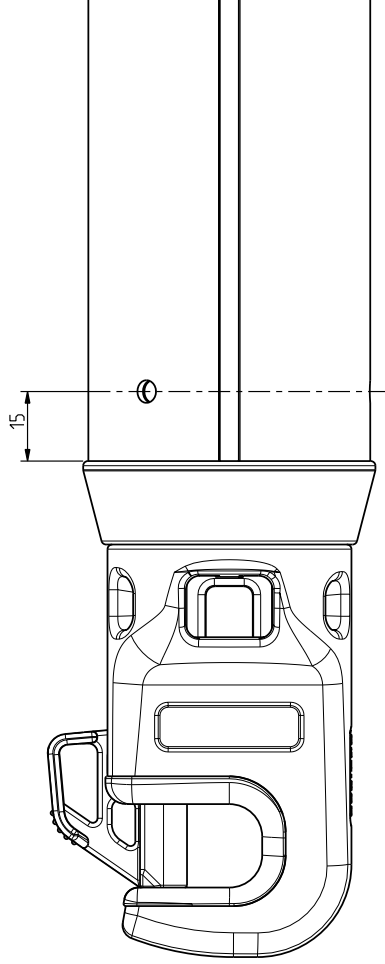

D (HOLE DIAMETER)	
RIVET	SCREW (SPINN. POLE KIT)
Ø4.9	Ø4

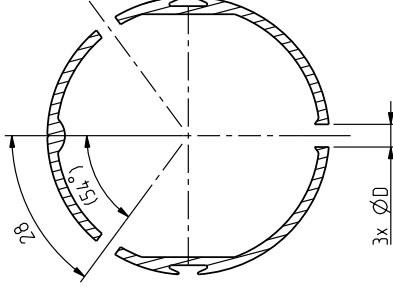

Item	Qty	Description	Dimension	Part No.
		SELDEN	LOCATION FASTENERS	
			SPINN POLE END	
			534-865	
		Tolerance acc. to SS-ISO 2768-x unless otherwise stated	Release	Revision File
Drawn	JG	Date	06-07-06	Scale
				1:1
		Replaced by	P	3050
		Replacing	Approved	Part No.
				PST35

No	Qty	Revision	Date	Sign

72/72 AND 84/84

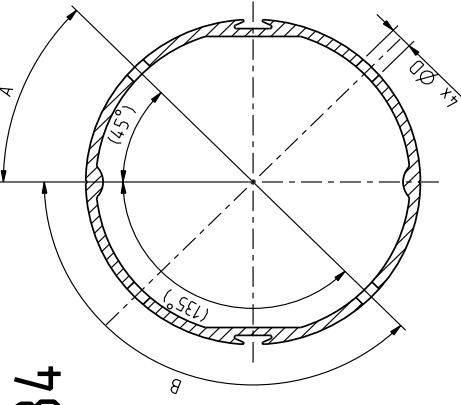

SECTION	A	B	C
72/72	29	86	90
84/84	33	99	105

D (HOLE DIAMETER)	
RIVET	SCREW (SPINN. POLE KIT)
Ø4.9	Ø4

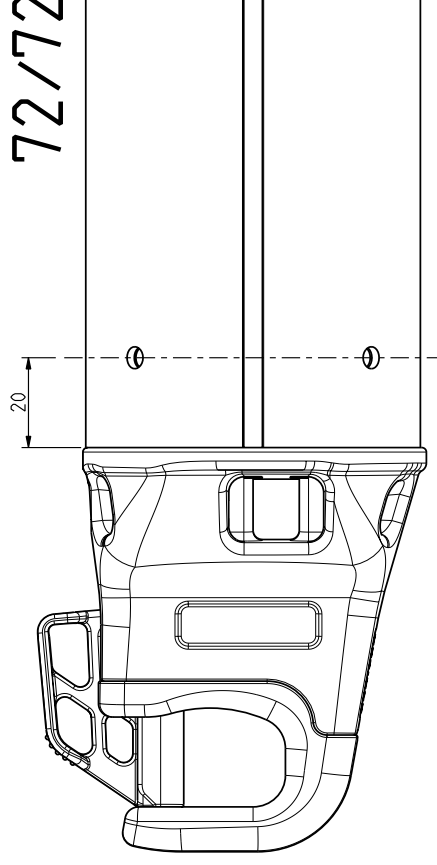

96/96

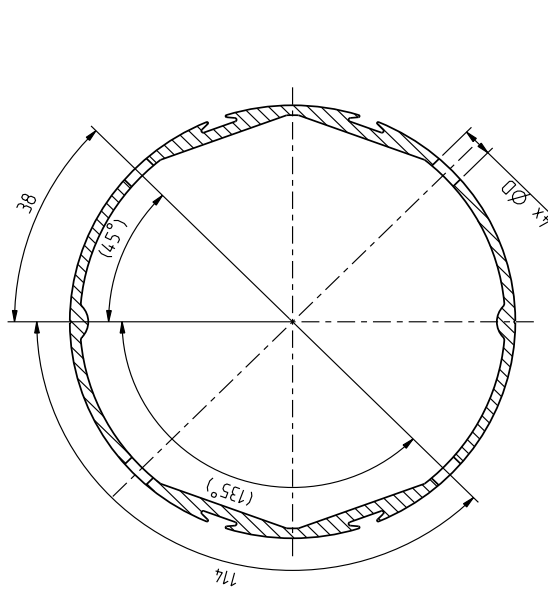

D (HOLE DIAMETER)	
RIVET	SCREW (SPINN. POLE KIT)
Ø6.5	Ø4

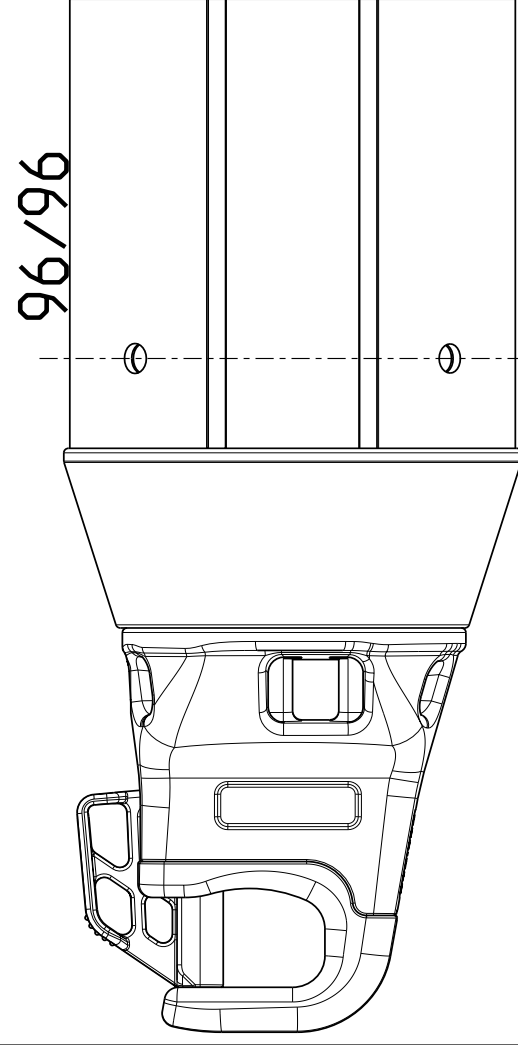

Item Qty	Description	Dimension	Part No.
	SELDEN		
	LOCATION FASTENERS		
	SPINN POLE END		
	534-854		
Tolerance acc. to SS-ISO 2768-c unless otherwise stated		Replaced by	Release
Drawn	JG	Date	06-07-06
		Scale	1:1
		Replacng	
		Approved	
		File	3050
No	Qty	Revision	PS736

No	Qty	Revision	Date	Sign

Notes/Comments

Dotted lines for writing notes or comments.

DINGHIES KEELBOATS YACHTS

Seldén Mast AB, Sweden
Tel +46 (0)31 69 69 00
Fax +46 (0)31 29 71 37
e-mail info@seldenmast.com

Seldén Mast Limited, UK
Tel +44 (0) 1329 504000
Fax +44 (0) 1329 504049
e-mail info@seldenmast.co.uk

Seldén Mast Inc., USA
Tel +1 843-760-6278
Fax +1 843-760-1220
e-mail info@seldenus.com

Seldén Mast A/S, DK
Tel +45 39 18 44 00
Fax +45 39 27 17 00
e-mail info@seldenmast.dk

Seldén Mid Europe B.V., NL
Tel +31 (0) 111-698 120
Fax +31 (0) 111-698 130
e-mail info@seldenmast.nl

Seldén Mast SAS, FR
Tel +33 (0) 251 362 110
Fax +33 (0) 251 362 185
e-mail info@seldenmast.fr

www.seldenmast.com

Dealer:

The Seldén Group is the world's leading manufacturer of masts and rigging systems in carbon and aluminium for dinghies, keelboats and yachts. The Group consists of Seldén Mast AB in Sweden, Seldén Mast A/S in Denmark, Seldén Mast Ltd in the UK, Seldén Mid Europe B.V. in the Netherlands, Seldén Mast SAS in France and Seldén Mast Inc in the USA. Our well known brands are Seldén and Furlex. The worldwide success of Furlex has enabled us to build a network of over 750 authorised dealers covering the world's marine markets. So wherever you sail, you can be sure of fast access to our service, spare parts and know-how.

