

Single Line Reef Conversion Kit

Instructions for modifying standard slab reefing

Tools Required

- Pilotlines
- Knife
- Tape
- Screwdriver (Phillips or Torx)
- Adjustable wrench or shackle opener
- Felt pen (for marking reefing lines)
- Sailmaker's needle and twine (for joining lines)
- Wire rope or similar. $L = \text{Boom length} + 50\text{cm}$. (For threading pilot lines)
- Trestles, clamp

What the Kit Contains

- 2 lines with an eye. Length $\sim E$ -measure
- 2 lines. Length $\sim 4x$ resp. $6x E$ -measure
- 2 shackles
- 2 plate blocks
- 2 single blocks
- 2 sheaves with pin and circular clips

Reefing Line Runs

- Reef # 1, blue lines: Outer starboard slot.
- Reef # 2, red lines: Outer portside slot.

1. Preparations

- 1.1 Place the boom on two trestles with the sail groove uppermost. Hold it with a clamp to prevent movement.
- 1.2 Remove the outboard end-fitting. (Phillips or Torx screws).
- 1.3 Pull out the reefing lines from the end-fitting, and fix them with tape so they do not disappear inside the boom.
- 1.4 Feed the wire through the starboard outer sheave slot on the upper side of the gooseneck fitting, and through the whole length of the boom. Check that it is not twisted around any reefing lines.
- 1.5 Tie a pilot line to the end of the wire and secure it with a piece of tape. Pull it through the boom. Secure the pilot line with tape at both ends of the boom.
- 1.6 Repeat this procedure on the port side of the boom.
- 1.7 Fit the shaft with its two sheaves in the upper hole in the gooseneck (see fig.). The sheaves must be in the outer slots, and the shaft secured with the circular clips. Ensure that the pilot lines run correctly round their respective sheaves.
- 1.8 Fit the loose single sheave blocks ④ to the holes in the flanges of the boom end-fitting. The shackle threads shall face out towards the boom section wall.

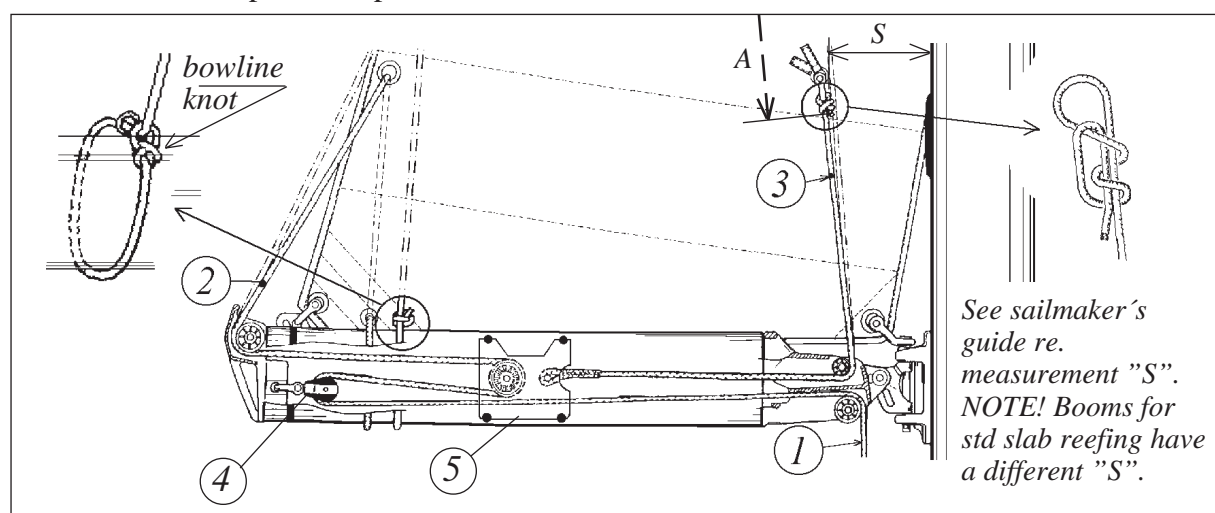

 **SELDÉN**

2. Fitting the Reefing Lines.

- 2.1. Select the short blue reefing line.
- 2.2. Tie the starboard pilot line at the aft end of the boom to the help loop sewn on the line.
- 2.3. Carefully pull the pilot line at the gooseneck until the reefing line appears. Remove the pilot line, and tie a stopper knot in the end of the reefing line.
- 2.4. Repeat actions 1, 2 and 3 with the short red reefing line on the port side of the boom.
- 2.5. Fit the plate blocks to the spliced eyes of the short reef lines③.
- 2.6. Feed the old port and starboard reefing lines through the single blocks through the plate blocks and out through the boom end sheave slots as illustrated.
- 2.7. Push in the plate blocks with their

anti-friction rollers. Adjustment of the bend angles of the blocks may be necessary to allow the block to fit into the extrusion. Check that it has plenty of play, but cannot dislodge.

- 2.8. Refit the boom end fitting. Grease the screws with Vaseline or similar to prevent corrosion.
- 2.9. Join the old reefing lines to the new long ones. (The old lines must be replaced as they are too short.) This is easiest done by sewing the lines together end-to-end and putting some tape over the join.
- 2.10. Pull through the new reefing lines. Make stopper knots in their ends.

3. Adjustment of Reefing Lines

- 3.1. Belay the reefing line① either in the cockpit or where the line exits the gooseneck fitting.
- 3.2. Pull the reefing line②, until the plate block ⑤ is stopped by the outer boom end fitting. Belay the line temporarily.
- 3.3. Tighten the reefing line③, and mark it where it exits the upper surface of the gooseneck fitting.
- 3.4. Free the reefing line①. Pull out about 1 m of reefing line③.
- 3.5. Put a new mark on the reefing line③ A mm nearer the block than the first mark. A acc. to the table below:

150 mm	for section	120/62
200 mm	— ” —	143/76
250 mm	— ” —	171/94
350 mm	— ” —	200/117
400 mm	— ” —	250/140

- 3.6. Tie on the shackle at the new mark with the knot illustrated. Ensure that the mark (A) is just visible below the knot. By using a shackle the knot does not have to be re-tied after each dismantling or refitting.
- 3.7. Undo reefing line②. Pull it through its reef cringle on the leech, and tie it to the boom with a little slack. It is important that the line is made fast exactly as illustrated to avoid the sail being torn. Fit the second reefing line in a similarly way.
- 3.8. Hoist the sail and check that the forward reefing lines③ are a little slack. Surplus line is cut off after any necessary adjustments have been made. Melt or whip the line ends.
- 3.9. Check that the boom has a topping lift or a fixed rod kicker to prevent it from dropping into the cockpit when reefing.

Caution!

The space between the boom sides and internal running blocks is limited. Check that new fittings, pop rivets or screws do not obstruct the movement of the blocks.

