

SmartPilot  
X-Series  
Commissioning &  
Setup Guide (SeaTalk)  
for SPX-10, SPX-30,  
SPX-SOL & SPX-CAN  
Systems

Document reference: 81307-1  
Date: December 2007

SeaTalk is a registered trademark of Raymarine Ltd.  
Raymarine, SeaTalk<sup>®</sup>, SmartPilot, AutoLearn, AutoRelease, AutoTack, AutoTrim, GyroPlus and WindTrim are trademarks of  
Raymarine Ltd

© Handbook contents copyright Raymarine plc

# Contents

Preface .....	iii
Safety notices .....	iii
EMC Conformance .....	iii
Warranty .....	iii
Pressure washing .....	iii
Product documents .....	iv
Product disposal .....	iv
Chapter 1:Procedures .....	1
1.1 Applicability .....	1
Requirement.....	1
SPX-CAN systems.....	1
Rudder reference information.....	2
SeaTalk Controller differences.....	2
1.2 Commissioning procedures .....	3
Dockside preparation.....	3
Step 1 - Switching on.....	3
Step 2 - Checking SeaTalk and NMEA connections .....	4
Step 3 - Checking rudder bar and steering operating sense .....	5
Step 4 - Dealer calibration settings.....	6
Finishing dockside preparation .....	10
Seatrial calibration .....	10
Getting started .....	10
Swinging the compass.....	11
Aligning compass heading.....	12
Aligning rudder bar .....	13
AutoLearn .....	14
Commissioning complete .....	16
1.3 Manual set-up .....	16
Requirement.....	16
Checking SPX system operation .....	16
Adjustable parameters.....	17
Setting response level .....	17
Rudder gain .....	17
Checking.....	17
Adjusting.....	18
Counter rudder .....	18
Checking.....	18
Adjusting.....	18
AutoTrim .....	19
Adjusting.....	19
Rudder damping.....	19
Chapter 2:SPX system settings .....	21
2.1 Introduction .....	21
Calibration modes .....	21
Display calibration.....	21
User calibration.....	21
Seatrial calibration .....	21
Dealer calibration.....	21
Accessing the Calibration modes.....	22
Adjusting calibration values .....	22

2.2 Display calibration .....	23
RUDD BAR screen .....	23
HDG screen.....	23
Data pages .....	23
Setting up data pages.....	24
2.3 User calibration .....	25
AutoTack (sail boat only).....	26
Setting default AutoTack angle.....	26
Selecting Relative Tack .....	26
Gybe inhibit (sail boat only).....	26
Wind selection (sail boat only) .....	26
WindTrim (sail boat only) .....	27
Response level.....	27
2.4 Dealer calibration .....	27
Seatrial calibration lock .....	28
Vessel type .....	28
Drive type .....	29
Align rudder .....	29
Rudder limit .....	30
Rudder gain .....	30
Counter rudder .....	30
Rudder damping.....	30
AutoTrim .....	30
Response level .....	31
Turn rate limit.....	31
Off course angle .....	31
AutoTack .....	32
Gybe inhibit.....	32
Wind selection .....	32
WindTrim .....	32
Power Steer .....	32
Cruise speed .....	33
Latitude .....	33
System reset.....	33
2.5 System defaults .....	35
SmartPilot X-Series Specifications.....	37
Glossary .....	39
Index.....	41

# Preface

## Safety notices



**WARNING:** Product installation & operation

This equipment must be installed, commissioned and operated in accordance with the Raymarine instructions provided. Failure to do so could result in personal injury, damage to your boat and/or poor product performance.



**WARNING:** Electrical safety

Make sure you have switched off the power supply before you make any electrical connections.



**WARNING:** Navigational safety

Although we have designed this product to be accurate and reliable, many factors can affect its performance. Therefore, it should serve only as an aid to navigation and should never replace commonsense and navigational judgement. Always maintain a permanent watch so you can respond to situations as they develop.

## EMC Conformance

All Raymarine equipment and accessories are designed to the best industry standards for use in the recreational marine environment. Their design and manufacture conforms to the appropriate Electromagnetic Compatibility (EMC) standards, but correct installation is required to ensure that performance is not compromised.

## Warranty

To register your new Raymarine product, please take a few minutes to fill out the warranty card. It is important that you complete the owner information and return the card to us to receive full warranty benefits. You can also register online at [www.raymarine.com](http://www.raymarine.com) by following the **Login or create an account** link.

## Pressure washing

Subjecting any Raymarine product to high pressure washing may cause subsequent water intrusion and failure of the product. Raymarine will not warranty product subjected to high pressure washing.

## Product documents

This document is part of a series of books associated with the Raymarine SmartPilot X (SPX) series of autopilot systems.

Title	Part number
ST6002 SmartPilot Controller Operating Guide	81269
ST7002 SmartPilot Controller Operating Guide	81270
ST8002 SmartPilot Controller Operating Guide	81271
ST70 AutoPilot Controller - SPX System Commissioning	81287
SmartPilot Surface Mount Controller Installation Guide	87058
SPX SmartPilot System Installation Guide, SPX 10, SPX 30, SPX Solenoid	87072
Fluxgate compass installation sheet	87011
Warranty Booklet	80017

These documents can be downloaded from [www.raymarine.com/handbooks](http://www.raymarine.com/handbooks)

To the best of our knowledge, the information in the product documents was correct when they went to press. However, Raymarine cannot accept liability for any inaccuracies or omissions in product documents.

In addition, our policy of continuous product improvement may change specifications without notice. Therefore, Raymarine cannot accept liability for any differences between the product and the accompanying documents.

## Important

This book does not apply to the SPX-5 series of autopilots. These have their own Installation & Setup Guides (Part Numbers 87075, 87075 and 87076).

## Product disposal



### **Waste Electrical and Electronic (WEEE) Directive**

The European WEEE Directive requires that waste electrical and electronic equipment is recycled.

Products carrying the crossed out wheeled bin symbol (illustrated above) must not be disposed of in general waste or landfill, but in accordance with local regulations for such products.

Although the WEEE Directive does not apply to all Raymarine products, we support its policy and ask you to be aware of the correct method for disposing of such products.

Please contact your local dealer, national distributor or Raymarine Technical Services for information on product disposal.

# Chapter 1: Procedures



**WARNING:** Calibration requirement  
All autopilot systems must be commissioned before use.

## 1.1 Applicability

This chapter describes the commissioning and initial setup procedures for the following combinations of Raymarine SmartPilot X (SPX) autopilot systems and Pilot Controllers:

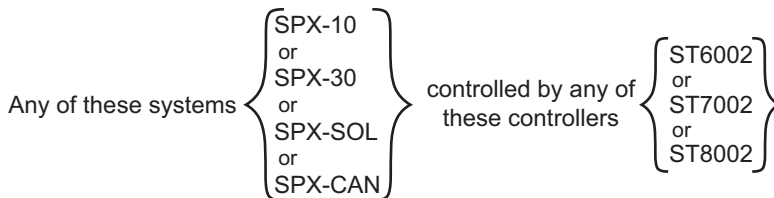

**Note:** *This book does NOT apply to SPX-5 systems or to systems using ST70 Pilot Controllers.*

If your SPX system is controlled with an ST70 Pilot Controller, the information in this book does not apply. Instead use the procedures in *ST70 AutoPilot Controller - SPX System Commissioning* (part no. 81287), to commission the system.

### Requirement

**The commissioning procedures are mandatory** and must be carried out after installation, before an SPX system is used to steer the boat. The commissioning procedures comprises a series of dockside preparatory procedures and a short seatrial.

Additional setup procedures enable you to fine tune your SPX system for optimum performance with your boat. These procedures are not mandatory and you may find that you do not need to use them if the SPX system operates to your satisfaction after commissioning.

### SPX-CAN systems

An SPX-CAN system connected to a Volvo Penta IPS system, must be auto-configured in accordance with the procedure in the SPX-CAN Installation Guide, before attempting to commission the SPX-CAN system.

If you experience any problems when commissioning and setting up an SPX-CAN system connected to a Volvo Penta IPS system, repeat the auto configuration procedure, then start the commissioning procedure again.

## Rudder reference information

In SPX-30, SPX-SOL & SPX-CAN systems, the rudder position is shown by a rudder reference bar and indicator on the Pilot Controller display.

**Note:** *The SPX-30 and SPX-SOL systems obtain rudder reference information from a rudder reference transducer. The SPX-CAN system rudder reference information is provided by the associated Volvo IPS system.*

The basic SPX-10 system is supplied without a rudder reference transducer, so in the basic system, the Pilot Controller display does not show a rudder reference bar or indicator. However, the SPX-10 system is compatible with the Raymarine rudder reference transducer, and this can be fitted as an option.

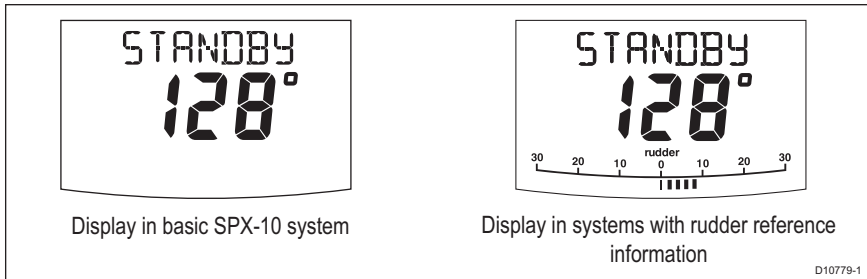

## SeaTalk Controller differences

Minor differences in the control functions of the ST6002, ST7002 and ST8002 SeaTalk Pilot Controllers are as follows:

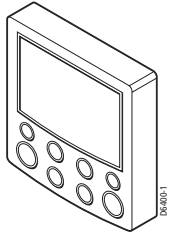
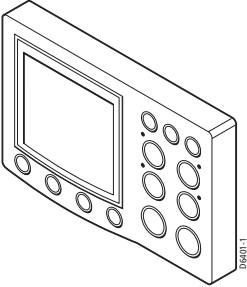
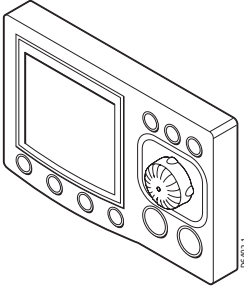
ST6002 Controller	ST7002 Controller	ST8002 Controller
		
<ul style="list-style-type: none"> <li>• <b>standby &amp; auto</b> function keys</li> <li>• <b>+1, -1, +10 &amp; -10</b> course change keys</li> <li>• <b>disp &amp; track</b> extended function keys</li> </ul>	<ul style="list-style-type: none"> <li>• <b>standby &amp; auto</b> function keys</li> <li>• <b>+1, -1, +10 &amp; -10</b> course change keys</li> <li>• <b>resp, track, mode, res'm, disp, up &amp; down</b> extended function keys</li> </ul>	<ul style="list-style-type: none"> <li>• <b>standby &amp; auto</b> function keys</li> <li>• <b>Rotary</b> course change control</li> <li>• <b>resp, track, mode, res'm, disp, up &amp; down</b> extended function keys</li> </ul>



## 1.2 Commissioning procedures

### Dockside preparation

The dockside preparation procedures comprise:

1. Switching on.
2. Checking SeaTalk and NMEA 0183 connections.
3. Checking rudder bar and steering operating sense, for either:
  - SPX-10, SPX-30 & SPX-SOL systems
  - or
  - SPX-CAN system
4. Dealer calibration settings. These are:
  - Setting vessel type and drive type.
  - Aligning rudder bar (if rudder reference transducer fitted).
  - Setting rudder limits (if rudder reference transducer fitted).



**WARNING:** Ensure safe control

For safe control of your boat, you **MUST** complete the dockside preparation before starting the initial seatrial.

If you are commissioning an SPX-CAN system connected to a Volvo Penta IPS system, ensure the IPS system has been auto-configured in accordance with the procedure in the SPX-CAN Installation Guide, before attempting to carry out the commissioning procedure.

**With the boat safely tied up**, complete the following dockside preparation.

### Step 1 - Switching on

1. When you have installed your SPX system, switch on the main power breaker.

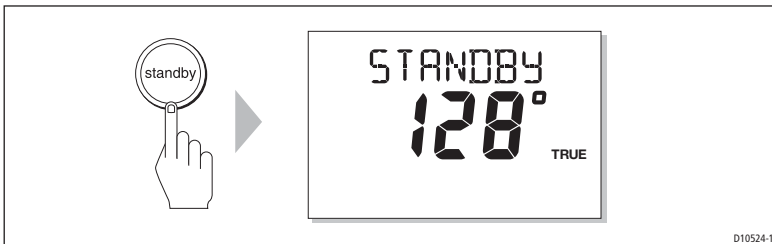

2. If the SPX controller and computer are active, the controller will beep and show the controller type for a few seconds, then show the **STANDBY** screen. You may also see a **CALIBRATE REQUIRED** message. This is displayed for a short time if either:
  - The vessel type is not selected.
  - The compass is not calibrated.
 These will be calibrated during commissioning.
3. Check that the **STANDBY** screen displays a live compass heading.

### Troubleshooting

- If the Pilot Controller does not beep or the display is blank, switch off the power, then check the fuse/circuit breaker and the SeaTalk fuse in the SPX Course Computer.
- If the display shows the **SEATALK FAIL** or **NO PILOT** alarm message, check the SeaTalk connections.
- If the **STANDBY** screen does not display a live compass heading, check the sensor connections.

## Step 2 - Checking SeaTalk and NMEA connections

### SeaTalk connections

If you have connected the Pilot Controller to other SeaTalk instruments or controllers, check the links as follows:

1. Select display lighting level 3 (**LAMP 3**) on one of the other SeaTalk instruments or controllers.
2. Check that the Pilot Controller display lights are on. If the lights are not on, check the SeaTalk cabling between the Pilot Controller and the other units.

### NMEA navigator connections

If the SPX system is connected to an NMEA navigator, ensure this is providing waypoint information, then check the links by displaying the default navigation data pages on the Pilot Controller:

1. Press disp to display the first data page (**XTE**), and check that this page shows the expected data.
2. Press disp again to check each successive data page (**BTW**, **DTW** etc).

If the display shows dashes instead of data values, ensure:

- The navigator is switched on and transmitting an active waypoint.
- The navigator is configured to transmit the required data format.
- There is not a cabling error. Check for open circuit, short circuit or reversed wires.

### Wind instrument connections

If the SmartPilot is connected to a SeaTalk or NMEA wind instrument, check the links as follows:

1. Simultaneously press standby and auto.

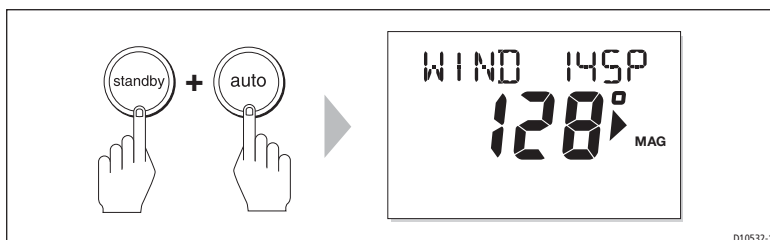

2. Check that the Pilot Controller displays the Wind Vane mode screen, with the locked wind angle and locked heading. If WIND mode is not displayed, the SPX system is not receiving wind data. Check the wind instrument and connections.

### Step 3 - Checking rudder bar and steering operating sense

Carry out the procedures appropriate to the system you are commissioning, i.e for either:

- SPX-10, SPX-30 or SPX-SOL system  
or
- SPX-CAN system connected to a Volvo IPS system.

#### SPX-10, SPX-30 & SPX-SOL systems

If a rudder reference transducer is fitted, check the rudder bar operating sense as follows:

1. Turn the wheel manually to starboard.
2. Check that the rudder bar on the controller display moves to starboard.

If the rudder bar moves the wrong way:

- i. Turn off the power.
- ii. Reverse the red and green wires connected to the RUDDER inputs on the SPX Course Computer.
- iii. Switch on the power and re-check.

Check the steering operating sense as follows:

1. Manually center the wheel, then press auto so the SPX system is in Auto mode.
2. Check that the display shows **AUTO**.

**Be ready to press standby if the rudder moves hardover.**

3. Press the **+10** key once or turn the **rotary control ½ turn** clockwise.

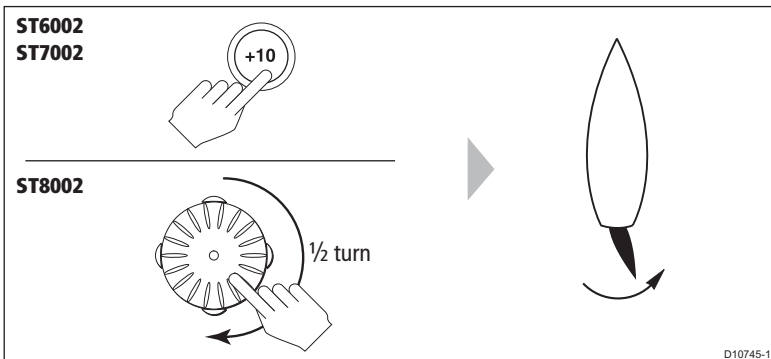

4. Check that the rudder moves to starboard a few degrees, then stops. If the rudder drives hard over, immediately press standby to prevent further rudder movement.
5. If the rudder moves to port or the rudder drives hard over:
  - i. Press standby.
  - ii. Turn off the power.
  - iii. Reverse the motor wires (on SPX-10 & SPX-30) or solenoid wires (on SPX-SOL), connected to terminals A and B on the SPX Course Computer.
  - iv. Switch on the power and re-check.

**Note:** If the rudder overshoots and has to drive back or starts to hunt back and forth, you will need to increase the rudder damping level manually (See page 30).

### SPX-CAN system connected to Volvo IPS system

Before making any adjustments to an SPX-CAN system, ensure the auto-configuration procedure (see the *SPX\_CAN System Installation Guide*) has been carried out.

Check the rudder bar operating sense as follows:

1. Power up the SPX-CAN system
2. Start the boat engine.
3. Turn the wheel manually.
4. Check that the rudder bar on the controller display follows the helm movement.  
If the rudder bar does not follow the helm, ensure the SPX-CAN system wiring is correct.

Check the steering operating sense as follows:

1. Manually center the wheel.
2. With the boat engine running, press auto.

**Be ready to press standby if the rudder moves hard over.**

3. Press the **+10** key once or turn the **rotary control ½ turn** clockwise.
4. Check that the rudder moves to starboard a few degrees, then stops. If the rudder drives hardover, immediately press standby to prevent further rudder movement.

## Step 4 - Dealer calibration settings

### Introduction



**WARNING:** Use Dealer calibration correctly

Improper use of Dealer calibration can seriously impair the SPX system performance and therefore adversely affect the steering capability. Do not change Dealer calibration settings other than as described in the product documentation.

To proceed with the dockside preparation, you need to carry out certain Dealer calibration setup functions. The exact requirement and consequently the calibration screens displayed, depend on which SPX system you are calibrating and whether a rudder reference transducer is fitted, as summarized in the following diagram.

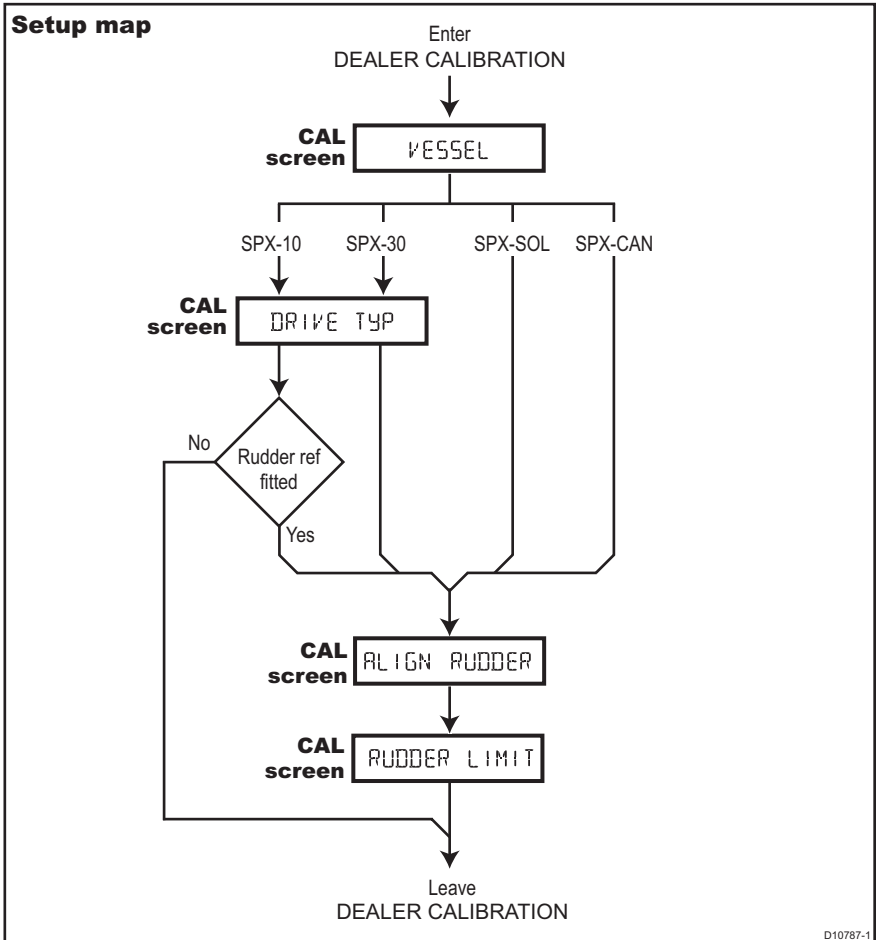

### Entering Dealer calibration

Enter Dealer calibration as follows:

1. Ensure the SPX system is in Standby mode.
2. Referring to the following table, use the appropriate procedure to enter Dealer calibration mode.

ST6002 Controllers	ST7002 and ST8002 Controllers
<ol style="list-style-type: none"> <li>1 Press and hold standby for two seconds to enter the Calibration mode</li> <li>2 When the screen shows <b>DISPLAY CAL</b>, press disp until you see the <b>DEALER CAL</b> screen</li> <li>3 Press auto: the display will change to <b>CAL</b></li> <li>4 Simultaneously press <b>-1</b> and <b>+1</b> to enter Dealer calibration mode</li> </ol>	<ol style="list-style-type: none"> <li>1 Press and hold standby for two seconds to enter the Calibration mode</li> <li>2 When the screen shows <b>DISPLAY CAL</b>, press disp or the up and down arrows, until you see the <b>DEALER CAL</b> screen</li> <li>3 Press auto: the display will change to <b>CAL</b></li> <li>4 Simultaneously press <b>-1</b> and <b>+1</b> (on the ST7002) or the up and down arrows (on the ST8002), to enter Dealer calibration mode</li> </ol>

**Note:** For more information on settings and calibration modes, refer to Chapter 2: SPX system settings.

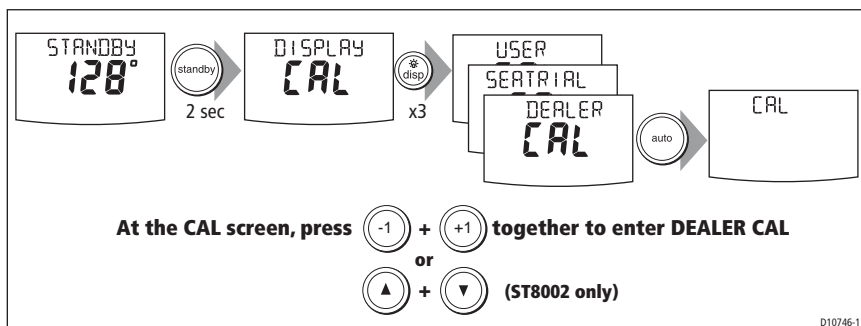

3. In Dealer calibration, access the vessel type screen, using disp if necessary. The vessel type screen shows either **VESSEL** or one of the vessel types (**DISPLACE**, **SEMI DISPLACE**, **PLANING**, **STERN DRV**, **WORK BOAT** or **SAIL BOAT**).

### Setting vessel type

The vessel type setting automatically determines appropriate default values for various other calibration settings. Some of these settings are checked later in this procedure and others should not require any adjustment. The default values for each vessel type are listed on page 35.

Set the vessel type as follows:

1. Use **-1** or **+1**, or the rotary control to set the appropriate vessel type, as in the following table.

Type	Description
<b>DISPLACE</b>	Power-driven boats which do not plane (Typically below 15 kts top speed)
<b>SEMI DISPLACE</b>	Faster power-driven boats which do not plane (Typically 15-20 kts top speed)
<b>PLANING</b>	Planing boats with inboard engine(s) and shaft drives (NOT boats with outdrives)
<b>STERN DRV</b>	Boats with outdrives or outboard engines

Type	Description
<b>WORK BOAT</b>	Commercial tugs, fishing vessels, etc
<b>SAIL BOAT</b>	Sailing boat

2. Press **disp** to confirm your selection and move to the next calibration screen. See the *Setup map* diagram above.

### Setting drive type

**Note:** On *SPX-SOL* and *SPX-CAN* systems, the drive type is set automatically so the *DRIVE TYP* calibration screen is not displayed.

On *SPX-10* and *SPX-30* systems the **DRIVE TYP** screen is displayed. Set the drive type as follows:

1. Use **-1** or **+1**, or the rotary control to set the appropriate drive type, as in the following table.

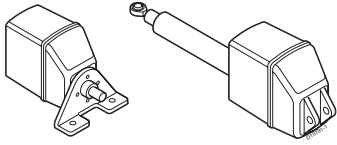
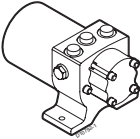
Drive	Drive Type Setting
	Drive Type 3 Linear Rotary Typically found on yachts  I/O (stern) Found on Powerboats
	Drive Type 4 Hydraulic reversing pump Used on yachts and powerboats with hydraulic steering

2. Press **disp** to confirm your selection and move to the next calibration screen. See the *Setup map* diagram above.

### Aligning rudder bar

If a rudder reference transducer is fitted, the **ALIGN RUDDER** screen is displayed.

Align the rudder indicator as follows:

1. Use the wheel to center the rudder.
2. Use **-1** or **+1**, or the rotary control to adjust the rudder indicator so it is at the center of the rudder bar on the Pilot Controller display.

The maximum adjustment available is  $\pm 9^\circ$ . If the offset is beyond these limits, you will need to physically adjust the alignment of the sensor.

3. Press **disp** to confirm the rudder bar alignment and move to the next screen. See the *Setup map* diagram above.

**Note:** You can also zero the rudder bar with the boat underway during the initial sea trial (see page 13).

### Setting the rudder limits

If a rudder reference transducer is fitted, the **RUDDER LIMIT** page displayed. Set the rudder limits as follows:

1. Turn the wheel to move the rudder:
  - i. To the port end stop and note the angle on the rudder bar.
  - ii. To the starboard end stop and note the angle on the rudder bar.
2. Use -1, +1, -10 and +10 or the rotary control to set the rudder limit to 5° less than the lowest angle you have noted.

### Finishing dockside preparation

Hold down standby for 2 seconds to save the Dealer calibration settings and return to Standby mode.

### Seatrial calibration

When you have successfully completed the dockside preparation, carry out a Seatrial calibration, to calibrate the compass and set up the autopilot steering characteristics.

#### Important

If you need to return to manual steering at any time during a Seatrial or any other procedure, **press the standby button**. NEVER compromise vessel safety.

#### EMC conformance

Always check the installation before going to sea to make sure that it is not affected by radio transmissions, engine starting etc.

This is particularly important when carrying out a Seatrial.

#### Seatrial conditions

The seatrial must be carried out only:

- In conditions of light wind and calm water.
- In waters that are clear of any obstructions, so the boat has plenty of clear space to maneuver.

In order to achieve optimum autopilot performance, course over ground (COG), speed over ground (SOG) or boat speed data are required at the SPX system (e.g. on SeaTalk). Ensure that the equipment providing this information (e.g. GPS), is switched on and fully operational, before starting a Seatrial.

### Getting started

Start the SeaTrial calibration as follows:

1. From Standby mode, hold down standby for 2 seconds, then press disp twice to see the **SEATRIAL CAL** screen.
2. Carry out the Seatrial calibration functions as described below, in the following sequence:
  - i. Swinging the compass
  - ii. Aligning compass heading
  - iii. Aligning rudder bar (only if rudder reference transducer is fitted)
  - iv. AutoLearn



## Swinging the compass

**Note:** This section does not apply if you have connected an NMEA compass to your SPX system. Refer to the handbook supplied with the NMEA compass for information about calibration.

The magnetic deviation correction procedure (commonly called “swinging the compass”) involves turning your boat in slow circles so the autopilot can automatically determine the deviation and apply any correction required. This procedure reduces deviation errors to a few degrees.

As magnetic deviation can cause significant compass errors on your boat, you **MUST** complete the compass swing before any other seatrial procedure.

To swing the compass:

1. With the SPX system in Standby mode, enter Seatrial calibration as follows:
  - i. Hold down standby for two seconds to enter Calibration mode.
  - ii. When you see the **DISPLAY CAL** screen, press disp until you see the **SEATRIAL CAL** screen.
  - iii. Press auto to enter Seatrial calibration.

**Note:** If you cannot access Seatrial calibration, disable the calibration lock. (see page 28).

2. Use disp as necessary, to move through the Seatrial Calibration items until you see **SWING COMPASS**.

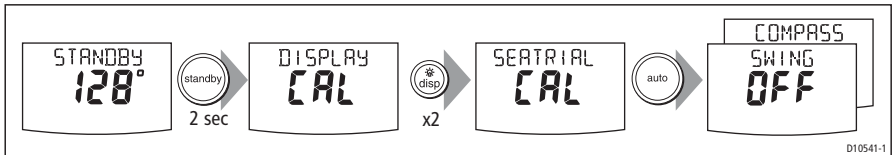

3. When you are ready to start, press +1, or turn the rotary control clockwise, to select **SWING COMPASS ON**.
4. Press auto to start the compass swing. The controller will display **TURN BOAT** indicating the start of the calibration process.
5. Ensuring you keep the boat’s speed below 5 knots, start slowly turning the boat in circles at a constant speed, maintaining a turn rate of approximately 3° per second, i.e. taking approximately 2 minutes to complete one turn. Complete at least two circles, in this manner.

If you turn the boat too quickly, the display will show a **TOO FAST** message. If this occurs, **apply less helm to reduce the rate of turn**.

**Note:** If necessary, you can quit the correction process by pressing standby or disp. If you then want to repeat the deviation correction, return to the **SWING COMPASS** screen.

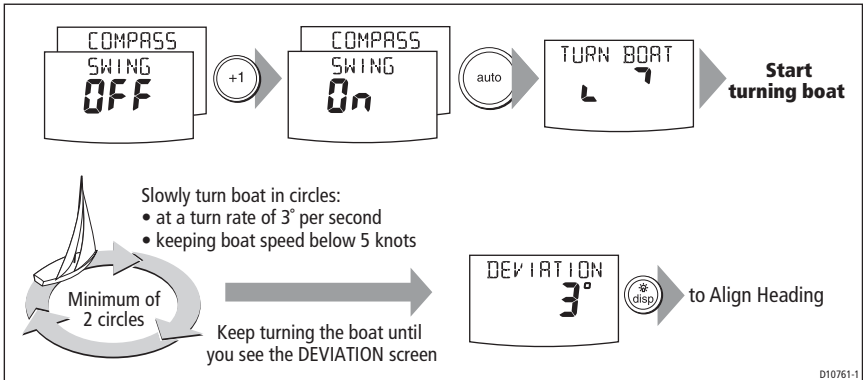

- Continue slowly turning the boat until the controller beeps and displays the **DEVIATION** screen. This indicates that the SPX system has completed the deviation correction.

**Note:** This screen shows the maximum deviation over 360° (not as an east/west value).

If the deviation figure exceeds 15°, the compass is being affected by ferrous objects on your boat. You should move the compass to a better location. Higher deviation figures are acceptable on steel boats.

### Aligning compass heading

Once the deviation is displayed, press **disp** to move to the Align Heading (**ALIGN HDG**) page, then:

- Manually steer the boat on a steady course at a speed sufficient to hold the course.
- If you have a GPS connected to your SPX system:
  - Increase the boat speed to more than 3 knots.
  - Press **auto**. The SPX system will then set the heading to agree with the COG (course over ground) heading received from the GPS.

As many factors can cause a difference between heading and COG, you must fine-tune the heading alignment to match the boat's steering compass (or a known transit bearing). To do this:

- Use **-1**, **+1**, **-10** and **+10** or the rotary control to adjust the displayed heading until it matches the boat's steering compass (or a known transit bearing).
- Hold down **standby** for 2 seconds to exit Seatrial calibration and save the new compass settings.

**Align the autopilot heading**

**(a) Coarse adjustment:** If COG is available from GPS, press  to set autopilot heading to COG value, then fine tune manually (see below).

**(b) Fine adjustment:** If COG is not available (or after setting heading to COG), align autopilot heading manually:

**ST6002 & ST7002**

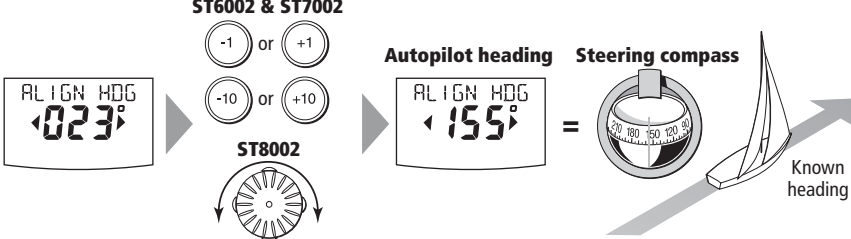



**Autopilot heading** = **Steering compass**

Adjust the autopilot heading so it shows the same value as the boat's steering compass

---

**Save changes**

 2 sec



To:

- save deviation correction
- save heading alignment
- return to STANDBY mode

D10277-1

Although compass calibration removes most of the alignment error, small errors (a few degrees) may remain. Once you have completed the initial compass calibration, you can make further adjustments to the alignment without having to swing the compass again.

Check the heading reading against a number of known headings, plot a deviation curve, and determine the heading alignment value that will give the lowest **average** alignment error. You can then enter this value on the Heading Alignment screen, as described above.

If the average heading error is more than 5°, check there are no items close to the compass that could cause an unwanted magnetic influence. You should also consider moving the fluxgate compass and performing the compass deviation correction procedure again, circling more slowly and in more favorable conditions.

## Aligning rudder bar

If the rudder reference transducer is fitted, use this procedure to align the rudder bar on the Pilot Controller display:

1. Access the **ALIGN RUDDER** screen in Seatrial calibration:
  - i. From Standby mode, hold down standby for 2 seconds, then press disp twice to see the **SEATRIAL CAL** screen.
  - ii. Press auto to enter Seatrial calibration, then press disp three times to see the **ALIGN RUDDER** screen.
2. Steer straight ahead then use -1, +1, -10 and +10 or the rotary control to set the displayed rudder bar to zero.

## AutoLearn



**WARNING:** Ensure there is enough clear sea space. The AutoLearn process takes the boat through a number of maneuvers, which can result in sudden, sharp turns, especially when the AutoLearn function is run on more maneuverable boats. Therefore, ensure there is a significant amount of **CLEAR SEA SPACE** in front of the boat, before starting an AutoLearn process.

The next stage of the Seatrial is to carry out an AutoLearn routine. This is a self-learning calibration feature that automatically adjusts rudder gain, counter rudder and AutoTrim for optimum performance on your boat.

If you need to return to manual steering at any time during an AutoLearn routine or any other procedure, **press the standby button**. NEVER compromise vessel safety.

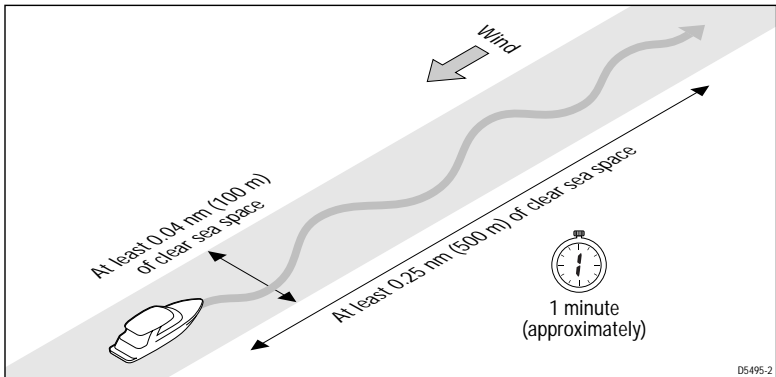

Ensure you have sufficient sea room to complete the AutoLearn, then carry out the AutoLearn as follows:

1. If you are not already in Seatrial calibration:
  - i. From Standby mode, hold down standby for 2 seconds, then press disp twice to see the **SEATRIAL CAL** screen.
  - ii. Press auto to enter Seatrial calibration
  - iii. Press disp four times to see the **AUTOLEARN** screen.
2. In Seatrial calibration, press disp as necessary, until the **AUTOLEARN** screen is displayed.
3. With the **AUTOLEARN** screen displayed, prepare to start the AutoLearn:
  - **power boats:** steer straight ahead (rudder centered). For non-planing boats, set a comfortable cruising speed. For planing boats set the speed so the boat is just planing.
  - **sail boats:** with the sails down, steer straight ahead (rudder centered) and motor the boat at typical cruising speed.
4. If conditions are not calm, head into the wind and waves.

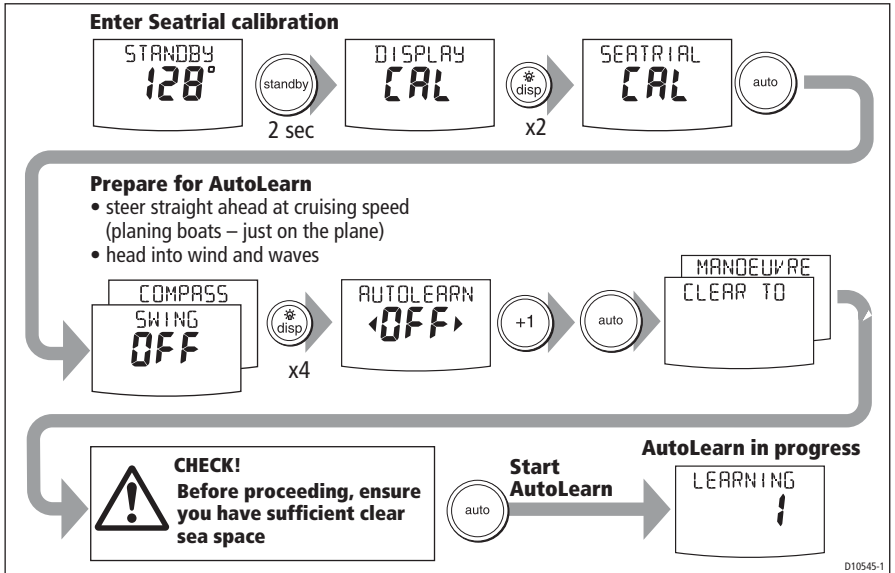

- When you are ready to proceed:
  - On ST6002 and ST7002 systems, press +1.
  - On ST8002 systems, turn the rotary control clockwise,
- Press auto. The screen will then show the **CLEAR TO MANOEUVRE** message.
- Ensure it is safe to continue, then press auto to start the AutoLearn maneuvers:
  - The boat will start a series of zig-zag turns and the display will show **LEARNING** with a number to indicate the current AutoLearn stage. This number increases as AutoLearn progresses.
  - A typical AutoLearn completes within 7 to 27 steps (depending on boat characteristics and sea conditions).

**Note:** To cancel an AutoLearn, press *standby* or *disp*.

- When the SPX system has finished learning, the controller will beep and display either **LRN PASS** or **LRN FAIL**:
  - **LRN PASS** = AutoLearn completed successfully
  - **LRN FAIL** = AutoLearn was not successful, so should be repeated. A failure code will also be displayed:
    - 1 = AutoLearn has not been carried out.
    - 2 = AutoLearn failed, due to manual interruption.
    - 3 Not used.
    - 4 = AutoLearn failed, probably due to drive or compass failure.
    - 5 = AutoLearn failed, probably due to motor current limiting.
    - 6 = AutoLearn failed, probably due to boat locking in a turn.
- If the AutoLearn was successful, hold down **standby** for 2 seconds to store the new settings.

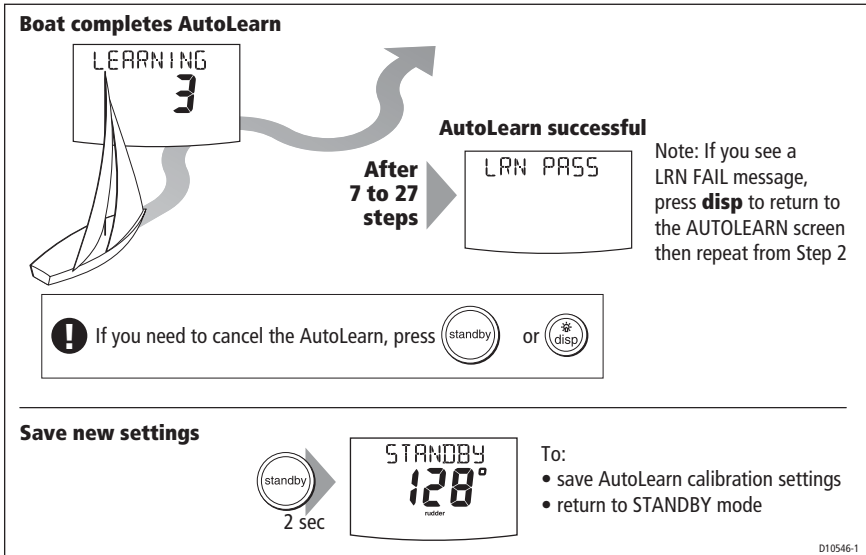

10. The seatrial is now complete. Hold down standby for 2 seconds to exit Seatrial calibration and save the settings.

## Commissioning complete

If you have successfully completed the dockside preparation and seatrial calibration, the SPX system is now commissioned and ready for use.

After you have used your SPX system, you may decide to change the value of some parameters to improve pilot performance with your boat. If you feel this is necessary, use the appropriate procedures under *Manual setup*, below.

## 1.3 Manual set-up

### Requirement

#### Checking SPX system operation

Before manually adjusting any settings, familiarize yourself with basic SPX system operation, as follows:

1. Steer onto a compass heading and hold the course steady at a normal cruising speed. If necessary, steer the boat manually for a short time to check how the boat steers.
2. Press auto to lock onto the current heading. The SPX system should hold the locked heading in calm sea conditions.
3. Use -1, +1, -10 and +10 and observe how the SPX system alters the course to port and starboard.
4. Press **standby** to return to manual steering.

## Adjustable parameters

If you feel you need to fine tune the SPX system performance, you can do so by using one or more of the procedures below to adjust:

- Rudder gain.
- Counter rudder
- AutoTrim.

If your SPX system 'hunts', i.e. continuously moves the steering backwards and forwards by small amounts, you can also adjust rudder damping to prevent this.

Over time you may wish to repeat these adjustments using a range of sea conditions and headings to achieve optimum all-round performance for your particular vessel and preferences.

Adjust these settings when motoring your boat at cruising speed.

## Setting response level

Before proceeding with any manual adjustment, set the response level to **5** as follows:

1. Enter Dealer calibration as described on *page 7*.
2. Use disp as necessary to access the **RESPONSE** screen.
3. Use the -1 or +1 key or the **up** and down arrow keys to set a response of **5**.
4. Hold down standby for 2 seconds to save the setting and leave Dealer calibration.

## Rudder gain

Boats can vary widely in their response to helm, and by adjusting the rudder gain you can change the steering characteristics of the SPX system. Rudder gain is a measure of how much helm the SPX system applies to correct course errors – higher settings mean more rudder is applied.

## Checking

Complete the following test to determine whether the rudder gain is set correctly:

1. Ensure you have set the SPX response to level **5**, as described above.
2. Motor your boat at a typical cruising speed in clear water.  
It is easier to recognize the steering response in calm sea conditions where wave action does not mask steering performance.
3. Press auto to enter Auto mode, then alter course by 40°:
  - If the rudder gain is adjusted correctly, the 40° course change should result in a crisp turn followed by an overshoot of no more than 5°.
  - If the rudder gain setting is too high, the 40° course change will result in a distinct overshoot of more than 5° and there may be a distinct 'S' in the course, as at **(A)**.  
Correct this oversteer by **reducing** the rudder gain, as described below.
  - If the rudder gain is too low, the boat's performance will be sluggish – it will take a long time to make the 40° turn and there will be no overshoot **(B)**.  
Correct this understeer by **increasing** the rudder gain, as described below.

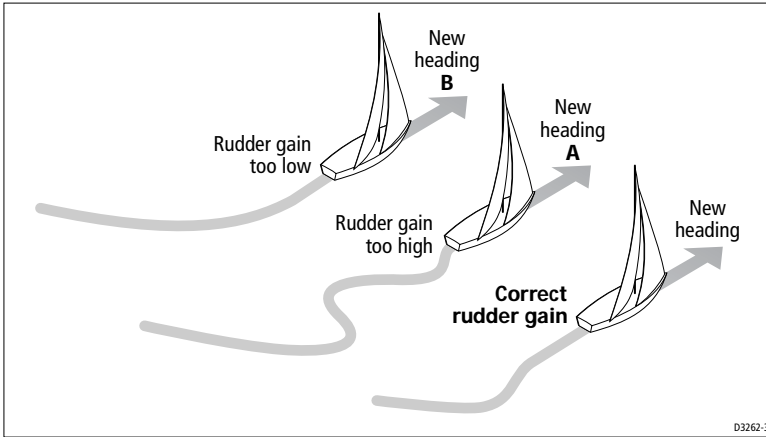

## Adjusting

To adjust the rudder gain:

1. Enter Dealer calibration as described on *page 7*.
2. Use disp as necessary to access the **RUDD GAIN** screen (see *page 30*).
3. Use the -1 or +1 keys or the rotary control to adjust the rudder gain.
4. Hold down standby for 2 seconds to save the changes and leave Dealer calibration.
5. Press auto to check SPX system performance in Auto mode.

## Counter rudder

Counter rudder is the amount of rudder the SPX system applies to try to prevent the boat oversteering. Higher counter rudder settings result in more rudder being applied.

## Checking

To check the counter rudder setting

1. Ensure you have set the response to level **5**, as described above.
2. Motor your boat at cruising speed in clear water.
3. Press auto to switch the SPX system to Auto mode, then make a 90° course change:
  - When gain and counter rudder are both set correctly, the boat performs a smooth continuous turn with minimal overshoot.
  - If the counter rudder is too low, the boat will still overshoot.
  - If counter rudder is too high, the boat will 'fight the turn' and make a series of short, sharp turns: this results in a very 'mechanical' feel as the boat changes course.

## Adjusting

To adjust the counter rudder:

1. Enter Dealer calibration as described on *page 7*.
2. Use disp as necessary to access the **COUNT RUD** screen (see *page 30*).



3. Use -1 or +1 or the rotary control to adjust the counter rudder.
4. Hold down standby for 2 seconds to save the changes and leave Dealer calibration.
5. Press auto to check the SPX system performance in Auto mode.

## AutoTrim

You may also need to adjust the AutoTrim setting. AutoTrim determines how quickly the SPX system applies 'standing helm' to correct for trim changes caused, for example, by changes in the wind load on the sails or superstructure, or an imbalance of engines.

Increasing the AutoTrim level reduces the time the SPX system takes to get back onto the correct course, but makes the boat less stable. If the SPX system:

- Gives unstable course keeping and the boat 'snakes' around the desired course, **decrease** the AutoTrim level
- Hangs off course for excessive periods of time, **increase** the AutoTrim level

## Adjusting

Before attempting to adjust the AutoTrim setting, ensure you have sufficient experience using the SPX system.

On sail boats you can only evaluate the effect of AutoTrim while under sail.

If you need to adjust AutoTrim, go up one level at a time and use the lowest acceptable value. The possible settings range from **OFF** (no trim correction) to **6** (fastest trim correction).

To adjust the AutoTrim:

1. Enter Dealer calibration as described on *page 7*.
2. Use disp as necessary to access the **AUTOTRIM** screen (see *page 30*).
3. Use -1 or +1 or the **rotary control**, to adjust the AutoTrim level.
4. Hold down standby for 2 seconds to save the changes and leave Dealer calibration.
5. Press auto to check the SPX system performance in Auto mode.

## Rudder damping

On SPX systems with a rudder reference transducer, you can set the rudder damping to prevent autopilot 'hunting', i.e. continuously moving the steering backwards and forwards by small amounts. To set up the rudder damping:

1. Enter Dealer calibration as described on *page 7*.
2. Use disp as necessary to access the **RUDD DAMP** page.
3. Use -1, +1, -10 and +10 or the rotary control to set the rudder damping so the hunting stops. Use the lowest rudder damping value at which hunting stops..
4. Hold down standby for 2 seconds to save the changes and leave Dealer calibration.



---

# Chapter 2: SPX system settings

## 2.1 Introduction

This chapter describes the SPX system calibration settings and factory default settings. The calibration settings can be adjusted to best suit your operating requirements, but as many will have been adjusted to optimum values when commissioning the system, they should not normally require further change.

If you change the calibration settings after the SPX system has been commissioned, you do not need to repeat the commissioning process. However, **DO NOT** manually adjust autopilot settings before the commissioning procedures in *Chapter 2* have been completed.

### Calibration modes

There are four calibration modes, namely Display calibration, User calibration, Seatrial calibration and Dealer calibration.

Each calibration mode uses a series of screens to set calibration values.

#### **Display calibration**

The items in Display calibration affect only the SPX system Pilot Controller. They are stored in the controller and do not affect any other controllers connected through SeaTalk.

You can adjust the Display calibration settings as often as necessary – for example, to add or change information displayed on data pages.

#### **User calibration**

The User calibration mode includes settings that you may need to adjust on a regular basis to respond to changing conditions.

#### **Seatrial calibration**

The Seatrial calibration mode is used **ONLY** when commissioning your SPX system, as described in *Chapter 3*, so is not described again here. **Do not access Seatrial calibration during normal operation.**

#### **Dealer calibration**

The Dealer calibration mode includes items that have a significant impact on operation and can affect your boat's safety.

After you have completed the initial installation and seatrial, you should not normally need to alter the Dealer calibration values.

## Accessing the Calibration modes

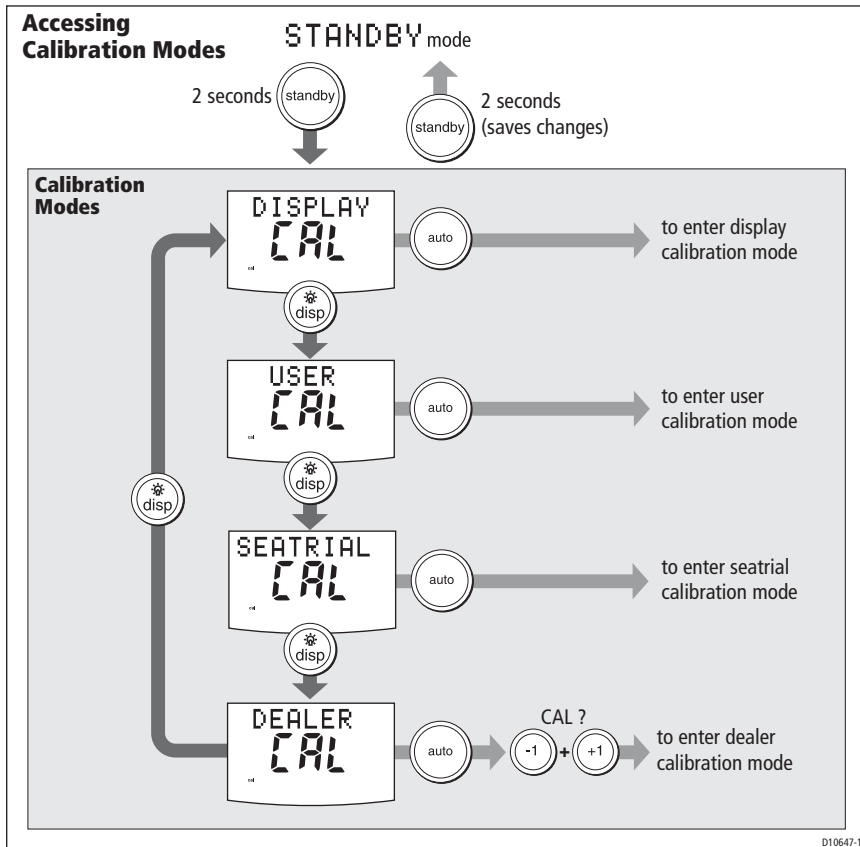

## Adjusting calibration values

To adjust calibration values:

1. Access the required calibration mode (refer to the diagram above).
2. Press disp to scroll through the available options. To view the previous option, press and hold disp for 1 second.
3. Use -1, +1, -10 and +10 to change the values.

When you have made all required changes, press and hold standby for 2 seconds to save changes and exit.

## 2.2 Display calibration

Display calibration provides settings to adjust the information displayed on the Pilot Controller.

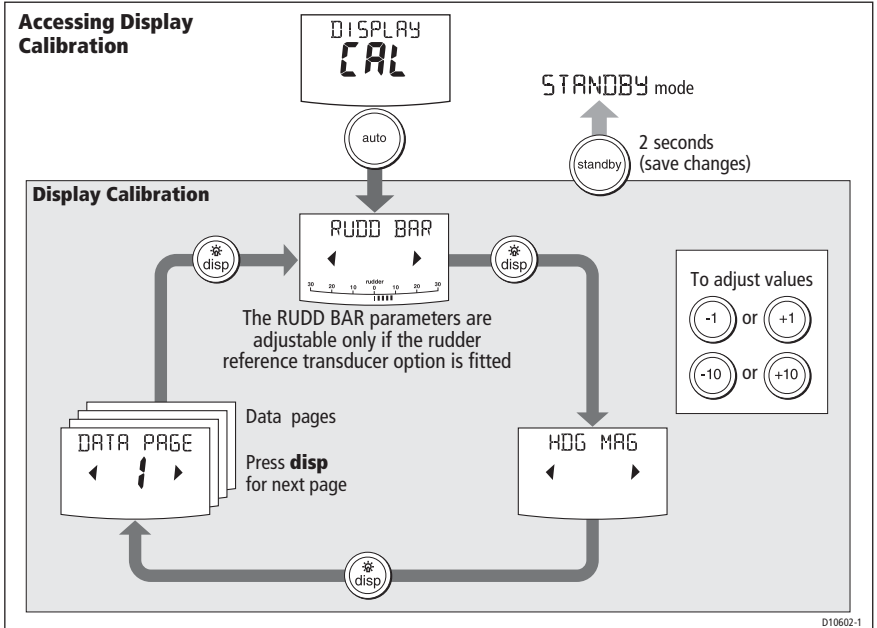

### RUDD BAR screen

This screen gives you access to the other Display calibration screens.

### HDG screen

You can choose whether to use magnetic or true heading data values. The options are:

- **HDG MAG** - Magnetic heading. If you select this, the screen will indicate **MAG** for heading values, during normal operation.
- **HDG TRUE** - True heading. If you select this the screen will indicate **TRUE** for heading values, during normal operation.

### Data pages

The Pilot Controller has fifteen user-configurable data pages. Each data page can be configured to display SeaTalk/NMEA data, which can be viewed during normal operation.

The default data page settings are:

Data Page	Default Setting
1	<b>XTE</b> (Cross Track Error)
2	<b>BTW</b> (Bearing to Waypoint) - see Note below
3	<b>DTW</b> (Distance to Waypoint) - see Note below
4	<b>RESPONSE</b>
Remaining pages	<b>NOT USED</b> (see <i>Setting up data pages</i> below)

## Setting up data pages

When setting up your data pages, we recommend that you:

- Retain the **BTW** and **DTW** data pages. If your SPX system receives a man overboard (MOB) message, these data pages will show the bearing and distance to the MOB location.
- Disable data pages you do not need to **NOT USED**. These will then not be displayed during normal operation, thereby improving the access time to the other data pages.

Available Data Pages	Displayed as
Speed Knots	<b>SPEED KTS</b>
Log	<b>LOG XXXX.X</b>
Trip	<b>TRIP XXX.X</b>
Average Speed	<b>AV. SPD</b>
Wind Direction	e.g. <b>WIND PORT</b>
Wind Speed	<b>WIND KTS</b>
Depth Metres	<b>DEPTH M</b> - see Note below
Depth Feet	<b>DEPTH FT</b> - see Note below
Depth Fathoms	<b>DEPTH FA</b> - see Note below
Heading	<b>HEADING</b>
Water Temperature, Degrees C	<b>WATER °C</b> - see Note below
Water Temperature, Degrees F	<b>WATER °F</b> - see Note below
Course Over Ground	<b>COG</b>
Speed Over Ground, Knots	<b>SOG KTS</b>
Cross Track Error	<b>XTE</b>
Distance to Waypoint	<b>DTW</b>

Available Data Pages	Displayed as
Bearing to Waypoint	<b>BTW</b>
Rudder Gain	<b>RUDD GAIN</b>
Response	<b>RESPONSE</b>
Watch	<b>WATCH</b> - used to control the Watch timer
Universal Time Coordinated	<b>UTC</b>

**Note:** There are 3 depth data pages (meters, feet and fathoms) and 2 water temperature data pages (°C and °F). The SPX system will display the depth data or water temperature in the units defined by the data page you select.

## 2.3 User calibration

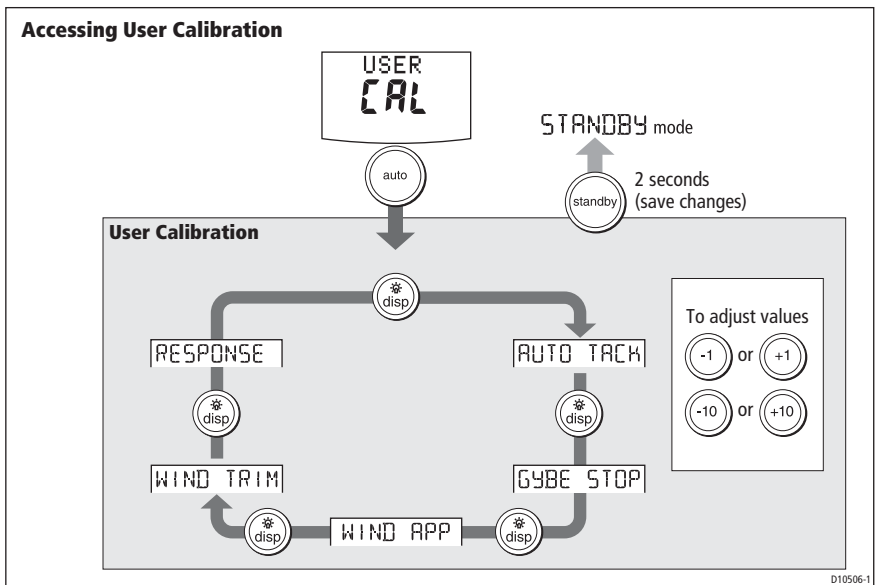

For information on how to access User calibration, see *Accessing the Calibration modes*, page 22.

The User calibration mode includes settings that you may need to adjust on a regular basis to respond to changing conditions.

## AutoTack (sail boat only)

Use this screen to select how the vessel performs when using AutoTack. You can either:

- Set a default AutoTack angle. This is the angle through which the boat will turn when an AutoTack is performed.  
or
- Select Relative Tack operation. With Relative Tack selected, the apparent wind angle when AutoTack is initiated, is mirrored the other side of the wind, on the opposite tack.

Screen Text	Options
<b>AUTO TACK</b>	40° to 125° in 1° steps

## Setting default AutoTack angle

To set the required AutoTack angle:

- If the SPX system is receiving wind information, set the AutoTack angle to the required change of heading.
- If the SPX system is not receiving wind information, set the AutoTack angle to 20° greater than the actual required change of heading.  
For example, to tack through 80° (i.e when sailing at 40° to the wind), set the AutoTack angle to 100°.

## Selecting Relative Tack

To select Relative Tack, use -1 and -10, to reduce the tack angle value to 30°. This action selects Relative Tack and the screen displays **rEL**, to indicate this.

## Gybe inhibit (sail boat only)

With gybe inhibit on:

- You will be able to perform an AutoTack into the wind
- The SPX system will prevent the boat from performing an AutoTack away from the wind, to prevent accidental gybes,

With gybe inhibit off, you can perform an AutoTack into or away from the wind.

Screen Text	Options
<b>GYBE STOP</b>	ON (Default) = Gybe inhibit on (gybes prevented) OFF = Gybe inhibit off (gybes permitted)

## Wind selection (sail boat only)

This screen determines whether the boat steers to apparent or true wind in Wind Vane mode.

Options	
<b>WIND APP</b> (Default)	SPX system steers to apparent wind angle
<b>WIND TRUE</b>	SPX system steers to true wind angle



## WindTrim (sail boat only)

WindTrim controls how quickly the SPX system responds to changes in the wind direction. Higher wind trim settings will result in a system that is more responsive to wind changes.

Screen Text	Options
<b>WIND TRIM</b>	Range = 1 to 9 1 to 3 - Least responsive to wind changes (less system activity) 4 to 6 - Moderate response to wind changes 7 to 9 - Most responsive to wind changes (more system activity)

## Response level

This sets the default SPX system response level. The response level controls the relationship between course keeping accuracy and the amount of helm/drive activity. You can make temporary changes to response during normal operation, as described in the Pilot Controller Operating Guide.

Screen Text	Options
<b>RESPONSE</b>	Range = 1 to 9 <b>Levels 1 to 3</b> minimize the amount of pilot activity. This conserves power, but may compromise short-term course-keeping accuracy <b>Levels 4 to 6</b> should give good course keeping with crisp, well controlled turns under normal operating conditions <b>Levels 7 to 9</b> give the tightest course keeping and greatest rudder activity (and power consumption). This can lead to a rough passage in open waters as the SPX system may 'fight' the sea.

## 2.4 Dealer calibration

For information on how to access Dealer calibration, see *Accessing the Calibration modes, page 22*.



### WARNING: Dealer calibration

Changing the Dealer calibration values can have a significant affect on the SPX system steering characteristics and therefore on the safety of your boat.

Some Dealer calibration values are adjusted during the commissioning process (see *Chapter 1: Commissioning & setup*), and once the SPX system has been commissioned you should not normally need to change Dealer calibration values.

However if you decide you want to change Dealer calibration values, be aware that many of these have a **significant impact on the SPX system operation and can affect your boat's safety**.

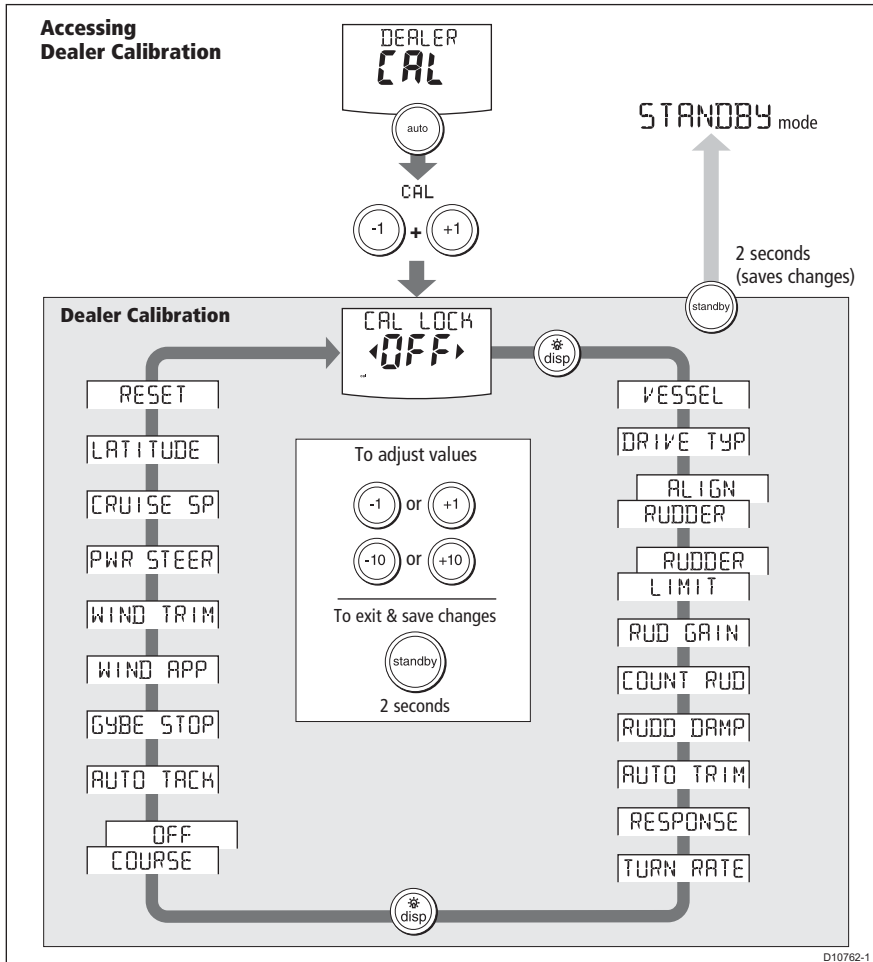

## Seatrial calibration lock

This screen controls the access to Seatrial calibration.

Screen text	Options
<b>CAL LOCK OFF</b>	Calibration lock off – Seatrial calibration can be accessed (default)
<b>CAL LOCK ON</b>	Calibration lock on – Seatrial calibration cannot be accessed

## Vessel type

Selecting the correct vessel type, enables the SPX system to set appropriate values for other calibration settings, to give optimum performance. Refer to the table on *page 35* for default values.

Options	
<b>DISPLACE</b>	Power-driven boats which do not plane (Typically below 15 kts top speed)
<b>SEMI DISPLACE</b>	Faster power-driven boats which do not plane (Typically 15-20 kts top speed)
<b>PLANING</b>	Planing boats with inboard engine(s) and shaft drives (NOT boats with outdrives)
<b>STERN DRV</b>	Boats with outdrives or outboard engines
<b>WORK BOAT</b>	Commercial tugs, fishing vessels, etc
<b>SAIL BOAT</b>	Sailing boat

### Drive type

The drive type setting controls how SPX-10 and SPX-30 systems drive the steering system.

**Note:** *On SPX-SOL and SPX-CAN systems, the DRIVE TYP calibration screen is not displayed, as the drive type is set automatically.*

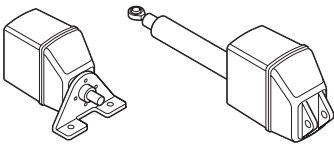
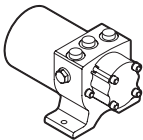
Drive	Drive Type Setting
 <p style="text-align: center; font-size: small;">D6404-1</p>	<p>Drive Type 3</p> <ul style="list-style-type: none"> <li>Linear</li> <li>Rotary</li> </ul> <p>Typically found on yachts</p> <p>I/O (stern)</p> <p>Found on Powerboats</p>
 <p style="text-align: center; font-size: small;">D6405-1</p>	<p>Drive Type 4</p> <ul style="list-style-type: none"> <li>Hydraulic reversing pump</li> </ul> <p>Used on yachts and powerboats with hydraulic steering</p>

### Align rudder

The align rudder screen is displayed only if a rudder reference transducer is fitted.

If a rudder reference transducer is fitted, use this screen is used to calibrate the rudder bar display. This should be set when commissioning the SPX system (see *page 34*).

Screen Text	Range
<b>ALIGN RUDDER</b>	-9° to +9° in 1° steps

## Rudder limit

The rudder limit screen is displayed only if a rudder reference transducer is fitted.

If a rudder reference transducer is fitted, this screen is used to set the limits of the rudder control just inside the mechanical end stops, and thus avoid putting the steering system under unnecessary load. This should be set when commissioning the SPX system (*see page 10*).

Screen Text	Range
<b>RUD LIMIT</b>	10° to 40° in 1° steps

## Rudder gain

Rudder gain is a measure of how much helm the SPX system applies to correct course errors. The higher the setting the more rudder will be applied.

The rudder gain setting is set automatically as part of the AutoLearn process (*see page 14*).

Screen Text	Range
<b>RUDDER GAIN</b>	1 to 9

## Counter rudder

Counter rudder is the amount of rudder the SPX system applies to try to prevent the boat from yawing off course. Higher counter rudder settings result in more rudder being applied.

The default counter rudder gain is set as part of the initial seatrial AutoLearn process (*see page 14*).

Screen Text	Range
<b>COUNT RUD</b>	1 to 9 (Do NOT set to 0)

## Rudder damping

On SPX systems with a rudder reference transducer, you can set the rudder damping to prevent autopilot 'hunting'. Increasing the rudder damping value reduces hunting. When adjusting the value, increase the damping one level at a time until the autopilot stops hunting. Always use the lowest acceptable value

Screen Text	Range
<b>RUDD DAMP</b>	1 to 9

## AutoTrim

The AutoTrim setting determines the rate at which the SPX system applies 'standing helm' to correct for trim changes caused by varying wind loads on the sails or superstructure.

The default AutoTrim is set as part of the AutoLearn process (see *page 14*).

If you need to change the setting, increase the AutoTrim one level at a time and use the **lowest** acceptable value:

- If the SPX system gives unstable course keeping or excessive drive activity with a change in the heel angle, decrease the AutoTrim level.
- If the SPX system reacts slowly to a heading change due to a change in the heel angle, increase the AutoTrim level.
- If the AutoTrim level is too high, the boat will be less stable and snake around the desired course.

Setting	Effect
<b>AUTO TRIM OFF</b>	No trim correction
<b>AUTO TRIM 1 to 6</b>	Auto trim applied: 1 = Slowest, 6 = Fastest

## Response level

This sets the default SPX system response level setting. The response level controls the relationship between course keeping accuracy and the amount of helm/drive activity. You can make temporary changes to response during normal operation (see your *Pilot Controller Operating Guide* for details).

Screen Text	Options
<b>RESPONSE</b>	Range = 1 to 9 <b>Levels 1 to 3</b> minimize the amount of pilot activity. This conserves power, but may compromise short-term course-keeping accuracy <b>Levels 4 to 6</b> should give good course keeping with crisp, well controlled turns under normal operating conditions <b>Levels 7 to 9</b> give the tightest course keeping and greatest rudder activity (and power consumption). This can lead to a rough passage in open waters as the SPX system may 'fight' the sea.

## Turn rate limit

This limits your boat's rate of turn under SPX system control.

Screen Text	Range
<b>TURN RATE</b>	1° to 30° per second in 1° steps

## Off course angle

This screen determines the angle used by the **OFF COURSE** alarm (see your *Operating Guide*). The **OFF COURSE** alarm operates if the pilot strays off course by more than the specified angle for more than 20 seconds.

Screen Text	Range
<b>OFF COURSE</b>	15° to 40° in 1° steps

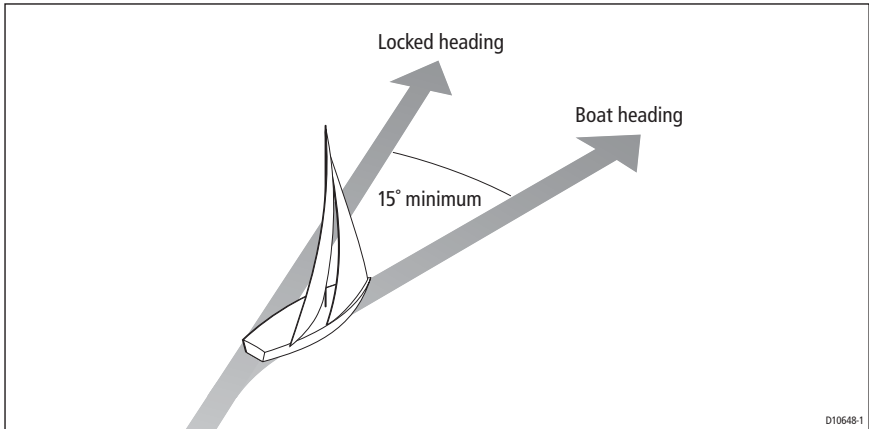

## AutoTack

The AutoTack angle is the angle through which the boat will turn when you select an automatic tack (see [page 26](#)).

## Gybe inhibit

With gybe inhibit on:

- You will be able to perform an AutoTack into the wind
- To prevent accidental gybes, the SmartPilot will prevent the boat from performing an AutoTack away from the wind

With gybe inhibit off, you can perform an AutoTack into or away from the wind. See also [page 26](#).

## Wind selection

**Note:** *Only available if appropriate wind data is available.*

This screen determines whether the boat steers to apparent or true wind in Wind Vane mode. See [page 26](#).

## WindTrim

WindTrim controls how quickly the SPX system responds to changes in the wind direction. Higher wind trim settings will result in a system that is more responsive to wind changes. See [page 27](#).

## Power Steer

If you have a joystick connected to your SPX system, use this screen to select the required joystick mode of operation. For detailed operating information, refer to the guide supplied with the joystick

Options	
<b>OFF</b>	Joystick off
<b>1</b>	<b>1 = Proportional power steer</b> Proportional power steer applies rudder in proportion to joystick movement – the further the joystick is held over, the greater the applied rudder.
<b>2</b>	<b>2 = Bang-bang power steer</b> Bang-bang power steer applies continuous rudder in the direction of the lever movement – to improve control, the speed of rudder movement changes with the angle of the lever. For maximum speed, push the lever hardover. If you return the lever to the center position, the rudder will remain in its current position.

## Cruise speed

Set the cruise speed to the boat's typical cruising speed. If neither the speed through the water nor the speed over ground are available via SeaTalk or NMEA, the SPX system will use the cruise speed value you set here as a default when adjusting autopilot settings.

Screen Text	Range
<b>CRUISE SP</b>	4 to 60 knots

## Latitude

If valid latitude data is available via SeaTalk or NMEA, the SPX system will use this data instead of the calibration value.

Screen Text	Range
<b>LATITUDE</b>	0° to 80° in 1° steps

## System reset

**CAUTION:** Losing settings at system reset

Do NOT carry out a System RESET unless advised to do so by a Raymarine dealer. If you complete a reset you will lose the SPX system calibration settings. You will then need to repeat the SPX system commissioning process.

Carrying out a System reset will reset User calibration, Seatrial calibration and Dealer calibration settings to their default values.

**Note:** *the Display calibration settings will not change, as these are stored in each individual controller*

To carry out a system reset:

1. Select the System reset (**RESET**) screen in Dealer calibration.
2. Press +1 then press auto.
3. The screen will then show an **ARE YOU SURE** message. Either:
  - Press auto to cancel the reset
  - or
  - Press +1 again to select **YES**, then press auto to reset the SPX system.

4. You will then see the **VESSEL** (vessel type) screen:

- Hold down standby for 2 seconds to save the new settings, then turn the SPX system computer power off and back on.

If you reset the system parameters, you must carry out the SPX system commissioning again before using the SPX system.



## 2.5 System defaults

<b>Vessel type</b>	Factory Default	Displacement	Semi-Displacement	Planing	Stern Drive (I/O)	Work Boat	Sail Boat
Calibration Lock	OFF	OFF	OFF	OFF	OFF	OFF	OFF
Vessel Type	0	DISPLACE	SEMI DISPLACE	PLANING	STERN DRV	WORK BOAT	SAIL BOAT
Drive Type*	3	4	4	4	3	4	3
Rudder Alignment	0	0	0	0	0	0	0
Rudder Limit	30	30	30	20	20	30	30
Rudder Gain	4	5	4	4	4	5	2
Counter Rudder	4	3	5	5	5	2	2
Rudder Damping	2	2	2	2	2	3	2
AutoTrim	2	2	3	3	3	2	1
Response:	5	5	5	5	5	5	5
Turn Rate Limit	5	5	5	5	5	5	5
Off Course Angle	20	20	20	20	20	20	20
Power Steer (Joystick)	1						
AutoRelease:	OFF				OFF		
AutoTack Angle	90	90					100
Gybe Inhibit	On	On					On
Wind Type	APP	APP					APP
Wind Trim	5	5					5
Cruise Speed	8	8	8	8	20	8	8
Latitude	0	0	0	0	0	0	0
Autopilot Reset	OFF	OFF	OFF	OFF	OFF	OFF	OFF

\*The drive type can only be set up for SPX-10 and SPX-30 systems. In SPX-SOL and SPX-CAN systems, appropriate drive type values are applied automatically and cannot be changed.



# SmartPilot X-Series Specifications

Nominal supply voltage	
X-10	12 or 24 V DC (fuse protected at 15A)
X-30	12 or 24 V DC (fuse protected at 40A)
X-SOLENOID	12 or 24 V DC (fuse protected at 15A)
X-CAN	12 or 24 V DC (fuse protected at 10A)
Operating voltage range	10 V to 32 V DC
Power consumption (standby) (all types)	300 mA
Gyro	internal GyroPlus fitted onto circuit board as standard
Environmental conditions	
operating temperature	-10°C to 55°C (14°F to 131°F)
non-operating temperature	-20°C to 70°C (-4°F to 158°F)
relative humidity limit	80%
water protection	drip resistant when mounted vertically
Storage conditions when packed	
temperature range	-5°C to 50°C (23°F to 122°F)
relative humidity limit	75%
Dimensions	(width, height, depth) 307mm (12.1 in), 195 mm (7.7 in), 70 mm (2.8 in)
Weight (all types)	2.2 kg (4.85 lbs)
Inputs	
All types	Fluxgate compass, NMEA 0183 v2.3, SeaTalk, SeaTalk <sup>ng</sup> , power, sleep switch.
X-10, X 30 & X-SOLENOID only	Rudder position sensor,
Outputs	
X-10, X -30	NMEA 0183 v2.3, SeaTalk, SeaTalk <sup>ng</sup> , drive motor, drive clutch
X-SOLENOID	NMEA 0183 v2.3, SeaTalk, SeaTalk <sup>ng</sup> , bypass valve, solenoid drive
X-CAN	NMEA 0183 v2.3, SeaTalk, SeaTalk <sup>ng</sup> , CAN (IPS)
Steering drive compatibility	
X 10	All Type 1 drives/pumps (excluding CR pumps) (drive voltage must match boat's supply voltage)
X 30	All Type 1, Type 2 and Type 3 drives / pumps (drive voltage must match boat's supply voltage)
X-SOLENOID	CR pumps etc.
X-CAN	Volvo Penta IPS system.
Drive motor output	
X-10	continuous 10A at supply voltage
X-30	continuous 30A at supply voltage

Drive clutch output	
X-10	1.2A at 12 / 24 V selectable
X-30	3.0A at 12 / 24 V selectable
X-SOLENOID	2.0A at 12 / 24 V selectable
SeaTalk output	
X-10	2A at 12 V (fuse protected at 2A)
X-30, X-SOLENOID	3A at 12 V (fuse protected at 3A)
X-CAN	3A at 12 V (fuse protected at 3A)
SeaTalk <sup>ng</sup> output	
X-10	2A at 12 V (fuse protected at 2A)
X-30, X-SOLENOID	3A at 12 V (fuse protected at 3A)
X-CAN	3A at 12 V (fuse protected at 3A)
NMEA 0183 v2.3 inputs/outputs	See relevant installation guide for received/transmitted NMEA 0183.
NMEA fast heading output	HDG
X-10, X-30, X-SOLENOID	10 Hz 0.1° resolution
X-CAN	
Fuses	Standard automotive blade fuses
Power Terminals	X-10: 15A. X-30: 40A. X-SOLENOID: 15A. X-CAN:10 A
SeaTalk Terminals	X-10: 2A. X-30, X-SOLENOID and X-CAN:3 A
EMC compliance:	Europe 2004/108/EC (EMC) Australia and New Zealand: C-Tick, Compliance Level 2

# Glossary

Term	Meaning
AST (Advanced Steering Technology)	AST (Advanced Steering Technology) is Raymarine's unique advanced steering algorithm. It uses inputs from a wide variety of sensors to tune the autopilot's operation to provide superior control of the boat in any condition.
AutoLearn	Self-learning calibration feature available on S1G, S2G and S3G systems.
AWG	American Wire Gauge
CE	Marked on products that comply with defined European Community standards
CR pump	Constant Running hydraulic pump
EMC (Electromagnetic Compatibility)	When powered up, all electrical equipment produces electromagnetic fields. These can cause adjacent pieces of electrical equipment to interact with one another, and this can degrade their performance. By following the EMC guidelines in this handbook, you can minimize these effects by ensuring optimum Electromagnetic Compatibility (EMC) between equipment.
Fluxgate	Standard Raymarine compass supplied with core pack
GPS	Global Positioning System
GyroPlus	Raymarine's GyroPlus yaw sensor that measures the boat's rate of turn. It is built into the S1G, S2G and S3G systems.
Hz	Hertz (cycles per second)
I/O drive	Inboard/Outboard or stern drive
MARPA	Mini Automatic Radar Plotting Aid
NMEA	The NMEA (National Maritime Electronics Association) protocol is an internationally accepted serial communication interface standard for sharing data between electronic equipment. Raymarine products can share information with non-SeaTalk equipment using the NMEA 0183 protocol.
SeaTalk	SeaTalk is Raymarine's proprietary communication system. It links products to provide a single, integrated system sharing power and data.
SeaTalk bus	This refers to the continuous SeaTalk system connecting together a series of Raymarine units.
Yaw	Boat's rate of turn (°/sec)



# Index

## A

- Accessing calibration modes, 22
- Applicability, 1
- AutoLearn, 14
- AutoTack, 26
  - selecting Relative Tack, 26
  - setting angle, 26
- AutoTack angle, 32
- AutoTrim, 19, 30

## C

- Calibration modes, 21
- Checking system operation, 16
- Commissioning
  - Dockside, 3
    - align rudder indicator, 9
    - check basic operation - NOT SPX-CAN, 5
    - check basic operation - SPX-CAN only, 6
    - checking connections, 4
    - checking pilot operating sense, 5
    - set drive type, 9
    - set rudder limits, 10
    - set vessel type, 8
    - switching on, 3
  - requirement, 1
  - Seatrial, 10
    - AutoLearn, 14
    - conditions, 10
    - heading alignment, 12
    - swinging the compass, 11
- Counter rudder, 18, 30

## D

- Data pages
  - available functions, 24
  - setup, 23
- Dealer Calibration
  - Gybe inhibit, 32
- Dealer calibration, 6
  - align rudder indicator, 29
  - AutoTack angle, 32
  - AutoTrim, 30
  - counter rudder, 30
  - cruise speed, 33
  - drive type, 29
  - latitude, 33
  - off course warning angle, 31
  - power steer, 32
  - response level, 31
  - rudder damping, 30
  - rudder gain, 30

- rudder limit, 30
- seatrial calibration lock, 28
- system reset, 33
- turn rate limit, 31
- vessel type, 28
- wind type, 32
- WindTrim, 32

- Default settings, 35
- Display calibration, 23
  - data page setup, 23
  - heading selection, 23
- Dockside procedures, 3
- Drive type, 29
  - setup, 9

## G

- Glossary, 39
- Gybe inhibit, 26

## H

- Heading alignment, 12
- Heading selection, 23

## J

- Joystick setup, 32

## L

- Latitude, 33

## M

- Magnetic/true heading selection, 23
- Manual setup
  - AutoTrim, 19
  - checking operation, 16
  - counter rudder, 18

## O

- Off course warning angle, 31

## P

- Power steer (joystick) mode, 32
- Product disposal, iv

## R

- Relative Tack, 26
- Resetting the system, 33
- Response level, 27, 31
- Rudder damping, 30
- Rudder gain, 30
  - setup, 17
- Rudder indicator alignment, 29
  - setup, 9
- Rudder limits, 30
  - setup, 10

- S
  - Safety
    - electrical, iii
    - general, iii
    - navigation, iii
  - Seatrial Calibration, 10
    - AutoLearn, 14
    - conditions, 10
    - heading alignment, 12
    - swinging the compass, 11
  - Seatrial calibration lock, 28
  - Settings
    - Gybe inhibit, 32
  - Setup
    - accessing calibration modes, 22
    - AutoTack, 26
    - AutoTack angle, 32
    - AutoTrim, 19, 30
    - counter rudder, 18, 30
    - cruise speed, 33
    - data pages, 23
    - drive type, 9, 29
    - for joystick operation, 32
    - gybe inhibit, 26
    - heading selection, 23
    - latitude, 33
    - off course warning angle, 31
    - power steer (joystick) mode, 32
    - response level, 27, 31
    - rudder damping, 30
    - rudder gain, 17, 30
    - rudder indicator alignment, 9, 29
    - rudder limit, 30
    - rudder limits, 10
    - seatrial calibration lock, 28
    - turn rate limit, 31
    - vessel type, 8, 28
    - wind type, 26, 32
    - WindTrim, 27, 32
  - SPX-CAN
    - auto-configuration requirement, 1
  - Swinging the compass, 11
  - Switching on, 3
  - System defaults, 35
  - System reset, 33
- T
    - Turn rate limit, 31
  - U
    - User calibration, 25
      - gybe inhibit, 26
      - response level, 27
      - wind type, 26
      - WindTrim, 27
  - V
    - Vessel type, 28
      - setup, 8
  - W
    - Wind type, 26, 32
    - WindTrim, 27, 32