

# EXTURN<sup>®</sup>

## INSTALLATION AND OPERATION MANUAL

EXTURN 110 | 130 | 180 | 230 | 300 | 400 | 600  
v2.0



# CONTENT

## 1. PREPARATION

1.1. Introduction	3
1.2. Safety Regualtions	3
1.3. Necessary Tools	3

## 2. PRODUCT CONTENTS

2.1. Mounting kit „Basic“	4
2.2. Mounting kit „Adapter“	5
2.3. Elektroniks and reference sticker	6
2.4. Control elements (separately available)	6
2.5. Cable Sets (separately available)	6

## 3. MOUNTING GENERAL

3.1. Mounting Variants	7
3.2. Restrictions	7
3.3. Choice of the mounting position	8
3.4. Measuring of the mounting position	8
3.5. Main drilling and sealing	9
3.6. The reference sticker	9
3.7. Redox reaction and mounting adjustments	10

## 4. MOUNTING KIT BASIC

4.1. Measuring of the mounting bolts	11
4.2. Bolting and sealing	11
4.3. Mounting illustration GRP	12
4.4. Mounting illustration steel and aluminium	13

## 5. MOUNTING KIT ADAPTER

5.1. Adapter positioning (round chine)	14
5.2. Bolting and sealing	14
5.3. Ausbildung Adaptersockel (Knickspant)	15
5.4. Mounting illustration GRP	18
5.5. Mounting illustration steel and aluminium	19

## 6. MOUNTING DUPLEX

6.1. General Instructions	20
6.2. Measuring of the mounting position	20

## 7. ELECTRICAL INSTALLATION

7.1. General Instructions	21
7.2. EXTURN and EXTURN Duplex Performance Specifications	21
7.3. Fuse protection and wire cross section	21
7.4. Choice of battery	22
7.5. Wiring	22
7.6. Installation of the E-BOX	22
7.7. Installation of joystick and touch panel (optional)	23
7.8. Installation of the radio remote control (optional)	23
7.9. Installation of multiple control elements	23

## 8. OPERATION

8.1. EXTURN as bow thruster	24
8.2. EXTURN as stern thruster	24
8.3. Bow and stern thrusters combined	25
8.4. Operation with multiple control elements	25
8.5. Important User Information	25
8.6. Maintenance	25
8.7. Troubleshooting	26

## 9. GUARANTEE BOND

**26**

## 10. APPENDIX

10.1. Dimension sheet EXTURN	27
10.2. Control Circuit Scheme EXTURN 12 V	28
10.3. Control Circuit Scheme EXTURN 24 V	29
10.4. Dimension sheet EXTURN Duplex	30
10.5. Control Circuit Scheme EXTURN Duplex 12 V	31
10.6. Control Circuit Scheme EXTURN Duplex 24 V	33
10.7. Technical Facts	35
10.8. Propeller Replacement	36
10.9. Template for joystick and touch panel	37

## 1. PREPARATION

### 1.1. Introduction

Thank you for choosing MARINNO's worldwide first external bow and stern thruster:

# EXTURN<sup>®</sup>

The driving power of the EXTURN bow and stern thruster depends on the boat length and assembly position: the efficiency, apart from the hull form, depends on various other factors, like, among other things, boat weight, freeboard surface, operational area and wind force.

The indicated power will be achieved under optimal circumstances. In order to ensure this, the choice of the assembly position, the assembly, as well as the electrical installation and wiring should be conducted with care and by specialists.

EXTURN has a substantial task: To increase safety and comfort on board. Regular maintenance work is not necessary. With professional assembly and with consideration of the recommendations contained in this manual, EXTURN will soon become indispensable for manoeuvring your boat.



### 1.2. Safety Regulations

Read this manual carefully. Provide the safety regulations also to all persons who are engaged with the assembly or the operation of EXTURN.

- The electrical installation must principally be accomplished by a specialist!
- During the operation of EXTURN never touch moving parts!
- Do not operate EXTURN, neither in the water nor outside of the water, if there are people standing close to the bow and stern thruster!
- When working on the EXTURN, always switch off the EXTURN main switch!
- Always switch the EXTURN main switch off when the bow and stern thruster is not used for a longer period!
- When craning, the belt may not be placed where it touches the EXTURN bow and stern thruster!

### 1.3. Necessary Tools

For the assembly of the EXTURN bow and stern thruster the following tools are needed depending on the mounting variant:

- Measuring tape
- Cord or levelling rule
- Hand drill
- Drill bits Ø 1,8 mm, 6 mm, 9 mm, 12 mm, 18 mm
- Hole saw Ø 50 - 51 mm
- Hole saw Ø 62 mm
- Pipe wrench size SW46
- Socket wrench size SW13
- Flat wrench size SW10
- Allen wrench size SW4
- Suitable sealant (e.g. Sikaflex)

## 2. PRODUCT CONTENTS

### 2.1. Mounting kit "Basic" (Article No. 50151)

#### Attachment "distance" (Article No. 50395):

4x safety nut M8



4x disk M8



1x sheet  
(B01.M5.003.B3)

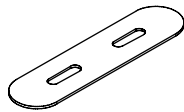

1x isolator  
(B01.M5.005.B3)

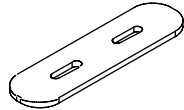

2x sealing D18 12,5 mm  
(B01.M5.006.B3)



4x sealing D18 25 mm  
(B01.M5.004.B3)



2x teflon-washer

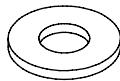

2x mounting bolt 250  
(B01.M3.002.B3)

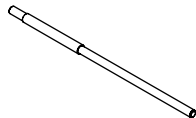

2x distance piece  
(B01.M5.001.B3)

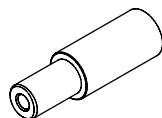

#### Attachment "main connection" (Article No. 50396):

2x hexagon nut

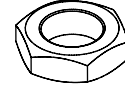

1x disk M30



1x disc  
(B01.M1.002.03)



1x metal sheet  
(B01.M1.001.03)

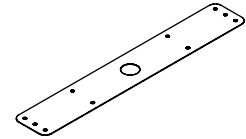

1x Dichtung D50 12,5 mm  
(B01.M1.003.03)

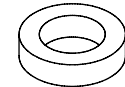

3x sealing D50 25 mm  
(B01.M1.004.03)

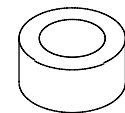

1x pad  
(B01.M1.005.03)

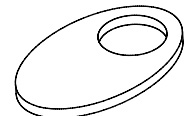

1x isolator  
(B01.M7.001.03)

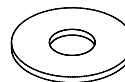

## 2.2. Mounting kit "Adapter" (Article No. 50152)

### Attachment "adapter" (Article No. 50390):

4x safety nut M8



4x disk M8



1x sheet  
(B01.M5.003.B3)

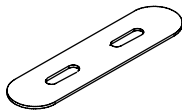

1x isolator  
(B01.M5.005.B3)

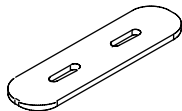

2x sealing D18 12,5 mm  
(B01.M5.006.B3)



4x sealing D18 25 mm  
(B01.M5.004.B3)



2x tefl on-washer

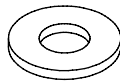

2x mounting bolt 250  
(B01.M3.002.B3)

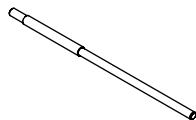

1x adapter  
(B01.M3.001.B3)

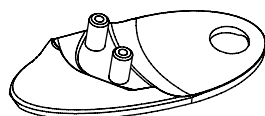

### Attachment "main connection GRP" (Article No. 50391):

2x hexagon nut

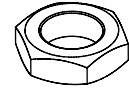

1x disk M30



1x disk  
(B01.M1.002.03)



1x metal sheet  
(B01.M1.001.03)

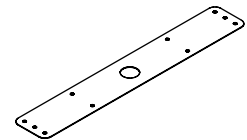

1x sealing D50 12,5 mm  
(B01.M1.003.03)

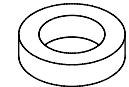

3x sealing D50 25 mm  
(B01.M1.004.03)

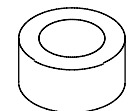

1x isolator  
(B01.M7.001.03)



### 2.3. Electronics and reference sticker

- 1x main relay (Article No. 50305)
- 1x E-BOX 103 (Article No. 50309)
- 2x crane operator reference sticker (black)
- 2x crane operator reference sticker (white)



Fig. 1: main relay



Fig. 2: E-BOX 103

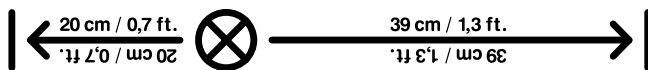

Fig. 3: crane operator reference sticker

### 2.4. Control Elements (separately available)

To operate EXTURN, one of the following separately available control elements is necessary:

- Control Element „joystick panel” (Article No. 50102):
  - (1) 1x joystick panel
  - (2) 1x seal
  - (3) 4x tapping screw
  - (4) 4x rubber plug

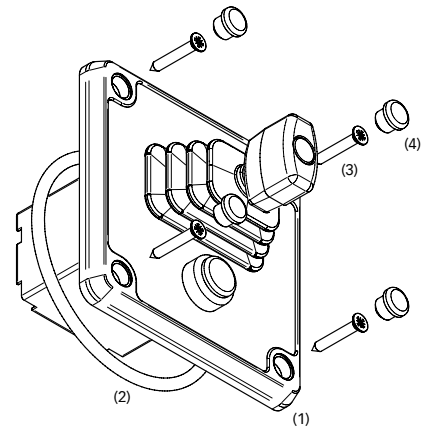

Fig. 4: joystick panel product content

- Control Element „touch panel” (Article No. 50101)
- Control Element „radio remote control” (Article No. 50105)



Fig. 5: radio remote control and receiver

### 2.5. Cable Sets (separately available)

Likewise, for the connection between E-BOX and bow thruster and main relay, a control cable with appropriate length is required:

- Control cable 2 m, incl. special connector (Article No. 50125)
- Control cable 8 m, incl. special connector (Article No. 50126)
- Control cable 15 m, incl. special connector (Article No. 50127)

Available for connecting the joystick or touch panel with the E-Box over a longer distance:

- Panel extension cable 2 m (Article No. 50120)
- Panel extension cable 6 m (Article No. 50121)

### 3. MOUNTING GENERAL

#### 3.1. Mounting Variant

The areas of application of the respective EXTURN mounting kits constitute as follows:

Area of application	Mounting kit „Basic“	Monuting kit „Adapter“
bow thruster ROUND CHINE	+	+
bow thruster HARD CHINE	-	+
stern thruster ROUND CHINE	+	+
stern thruster bathing platform	+	+
stern thruster “vertical transom”	+	-

#### 3.2. Restrictions

EXTURN as bow thruster:

- The permitted driving speed for the use of EXTURN is 35 knots (no constant load!).
- From approx. 15 knots driving speed EXTURN must be outside the water!

**CAUTION!**

The permitted driving speed for the use of EXTURN is 35 knots!

EXTURN as stern thruster:

- The mounting on the slide surface of a glider is not permitted!
- On GRP-boats with a speed from 12 knots the hull construction must comply to the guidelines of GL (Germanic Lloyd)!
- It has to be assured that the incident flow of the rudder and drive is not affected!
- The propeller needs free sight at starboard and port, so it is not permitted to mount two EXTURNS side by side in one axis!

**CAUTION!**

The mounting on the slide surface of a glider is not permitted!

### 3.3. Choice of the mounting position

The mounting of the EXTURN bow and stern thruster is unbelievably simple and can be carried out without large expenditure of time. Nevertheless, it should principally be done by a specialist.

In order to achieve the optimal efficiency of EXTURN when used as bow thruster, it should be positioned as far down and in front as possible, though 30 cm under the waterline is sufficient.

When operated as a stern thruster, naturally, it should be positioned as far down and in the back as possible, however, again, 30 cm under the waterline is sufficient.

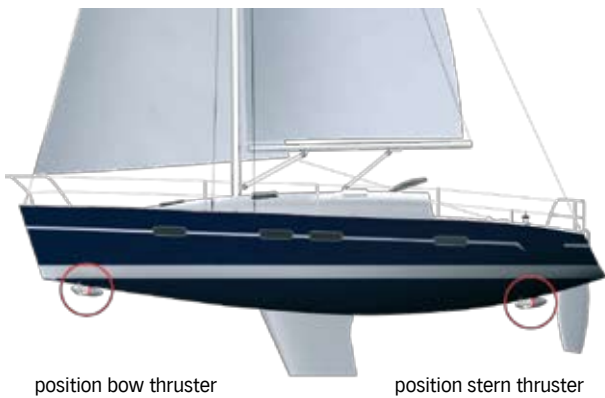

Fig. 6: mounting sailboat

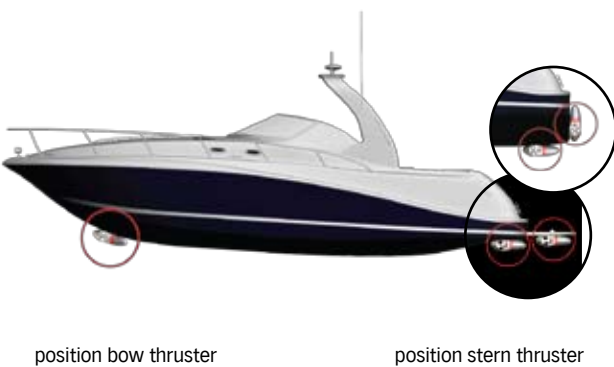

Fig. 7: mounting motorboat

### 3.4. Measuring of the mounting position

The EXTURN bow and stern thruster must be positioned exactly on the middle line of the boat. In order to determine this, it is recommended to draw a line from the keel to the bow or stern with a cord or a measuring tape and fix it. Subsequently, by means of this line, the desired position can be shifted easily forward or backward.

For the choice of the mounting position, it is to be likewise made certain that the required hole with a diameter of 50 - 51 mm is not drilled at an unsuitable position (e.g. bulkhead). The metal sheet to be used (except on steel and aluminium boats) has a width of 80 mm. So that it can be placed without problems, the borehole must be at least 60 mm from the next bulkhead. For the reasons mentioned above, the positioning should be measured exactly in any case before the execution of the drilling, also inside the boat.

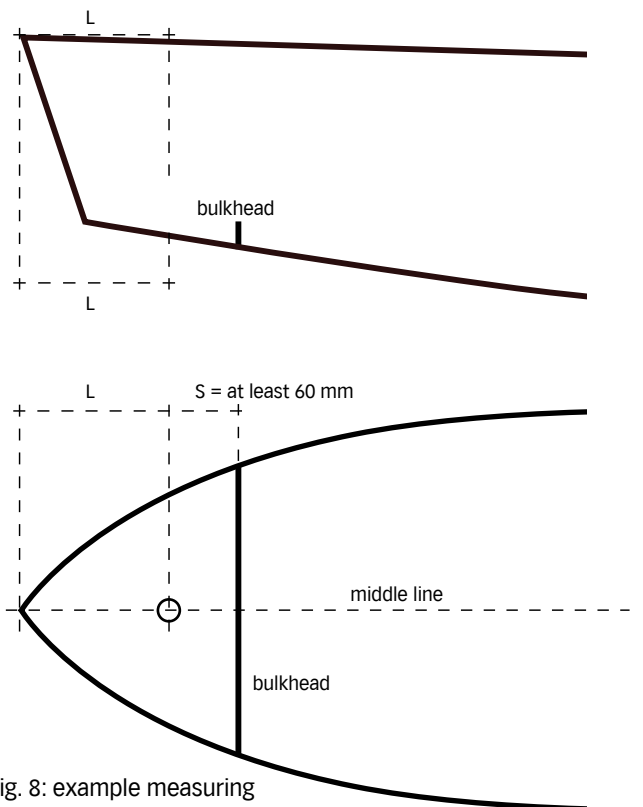

Fig. 8: example measuring



When mounted on a glider waterline and gliding line have to be marked with a tape. The bottom edge of EXTURN has to be above the gliding line by all means!



Fig. 9: measurement on a glider

**CAUTION!**

On a glider the bottom edge of EXTURN has to be above the gliding line by all means!

**3.5. Main drilling and sealing**

The drilling for the hollow shaft needs a diameter of 50 - 51 mm. It is recommended to use a hand-held drill.

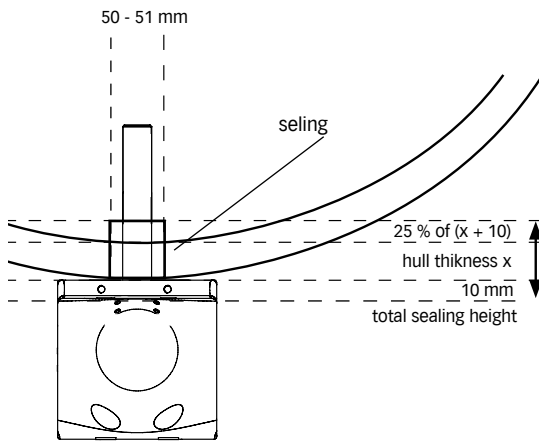

Fig. 10: drilling and total sealing height

Subsequently, exactly measure the height of the drill hole, it is very important for the sealing. Depending on the hull thickness, several seals must be used. It is to be considered that those seals are compressed by about 25 % when tightening the bolts.

The total sealing height results as follows:

**hull thickness x 1,25**

Example: Total sealing height with hull thickness of 30 mm:

$30 \times 1,25 = 40 \text{ mm}$

**3.6. The reference sticker**

After conclusion of the mounting, the reference stickers for the crane operator should be attached to both sides of the boat hull, as demonstrated in fig.11, to indicate the position of the bow and stern thruster.

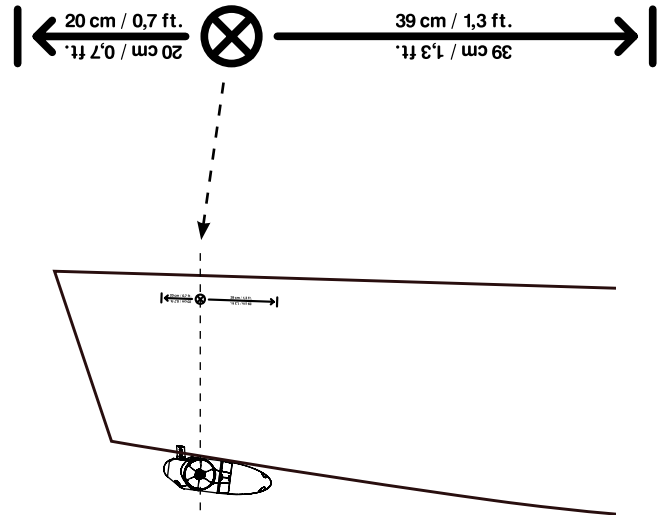

Fig. 11: attaching crane operator reference sticker

**CAUTION!**

The craning belt may not be placed where it touches the EXTURN bow or stern thruster!

### 3.7. Redox reaction and mounting adjustment

It is necessary to pay attention to special material properties to assure correct potential equalization and avoid redox reaction between EXTURN and the boat hull. (see table).

Since mounting with welded bolts is possible on hulls out of steel or aluminium, it has to be adjusted to the respective hull. However, it is recommended to use the provided mounting kits.

	<b>GRP</b>	<b>Steel</b>	<b>Aluminium</b>	<b>Wood</b>
<b>Specifics</b>	none	direct contact prevention between EXTURN and fastening elements and hull	direct contact prevention between fastening elements and hull	none
<b>Critical range</b>	none	8 mm	2 mm	none
<b>Usage of welded mounting bolts</b>	-	must be isolated from EXTURN with rubber	must not be isolated from EXTURN	-
<b>Usage sealing "main connection"</b>	compelling	compelling	compelling	compelling
<b>Usage "metal sheet"</b>	compelling	no!	no!	yes
<b>Usage "isolator"</b>	no	compelling!	compelling!	no

#### **CAUTION!**

On hulls out of steel or aluminium after mounting it has to be verified with a multimeter that there is no direct connection between the EXTURN bow and stern thruster and the boat hull!!!

## 4. MOUNTING KIT BASIC

### 4.1. Measuring of the mounting bolts

First the pad (1) must be glued on the bow thruster. Afterwards mount the thruster temporary via the main connection and mark the front boreholes for the mounting bolts.

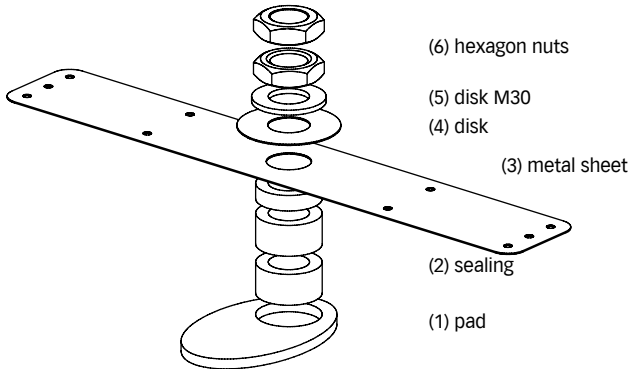

Fig. 12: main connection GRP

Measure the length for the distance pieces (fig. 13) and demount the thruster. Then make the drillings for the mounting bolts with diameter 9 mm (on GRP) or 18 mm (on steel or aluminium) and cut the distance pieces as measured before (fig. 14).

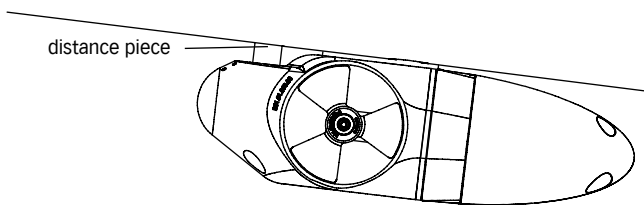

Fig. 13: distance piece length

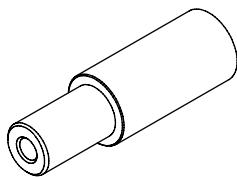

Fig. 14: distance piece

### CAUTION!

On hulls out of steel or aluminium it is compellent to use the isolator instead of the metal sheet!

### 4.2. Bolting and sealing

Bolt down the thruster via the main connection, thereby paying attention to the right number of seals (fig. 10). The sequence corresponds to the one in fig. 12, whereby, depending on the hull thickness, several seals (2) must be used. It is to be considered that those seals are compressed by about 25 % when tightening the bolts (fig. 10).

Ideally, coat the metal sheet (3) at the lower surface with sealant (e.g. Sikaflex). Don't press it to the hull by hand so that the metal sheet can adapt to the hull shape automatically when tightening the bolts. Apply disk (4) and disk M30 (5) and tighten the two hexagon nuts (6) firmly. Thereby the sealings (2) are compressed and fill out the drill hole completely. It is recommended to press against the thruster from the outside to prevent the sealings from being pressed out of the borehole when tightening the bolts. The metal sheet (3) adapts to the hull shape.

On hulls out of steel or aluminium it is compellent to use the isolator instead of the metal sheet (see 4.4. Mounting illustration steel and aluminium)!

Finally plug the distance pieces on the thruster. Insert the mounting bolts like illustrated in fig. 15 cutting them in the boat interior as necessary. Apply seals (2) according to the hull thickness (note: hull thickness + 25 %). On hulls out of GRP and boreholes of 9 mm the seals (2) can be omitted by using suitable sealant (e.g. Sikaflex).

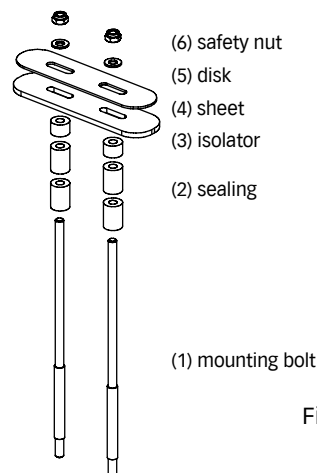

Fig. 15: assembly mounting bolts

Total sealing height for mounting bolts:

**hull thickness x 1,25**

Example: total sealing height with hull thickness 30 mm:

$$30 \times 1,25 = 37,5 \text{ mm}$$

### 4.3. Mounting illustration GRP

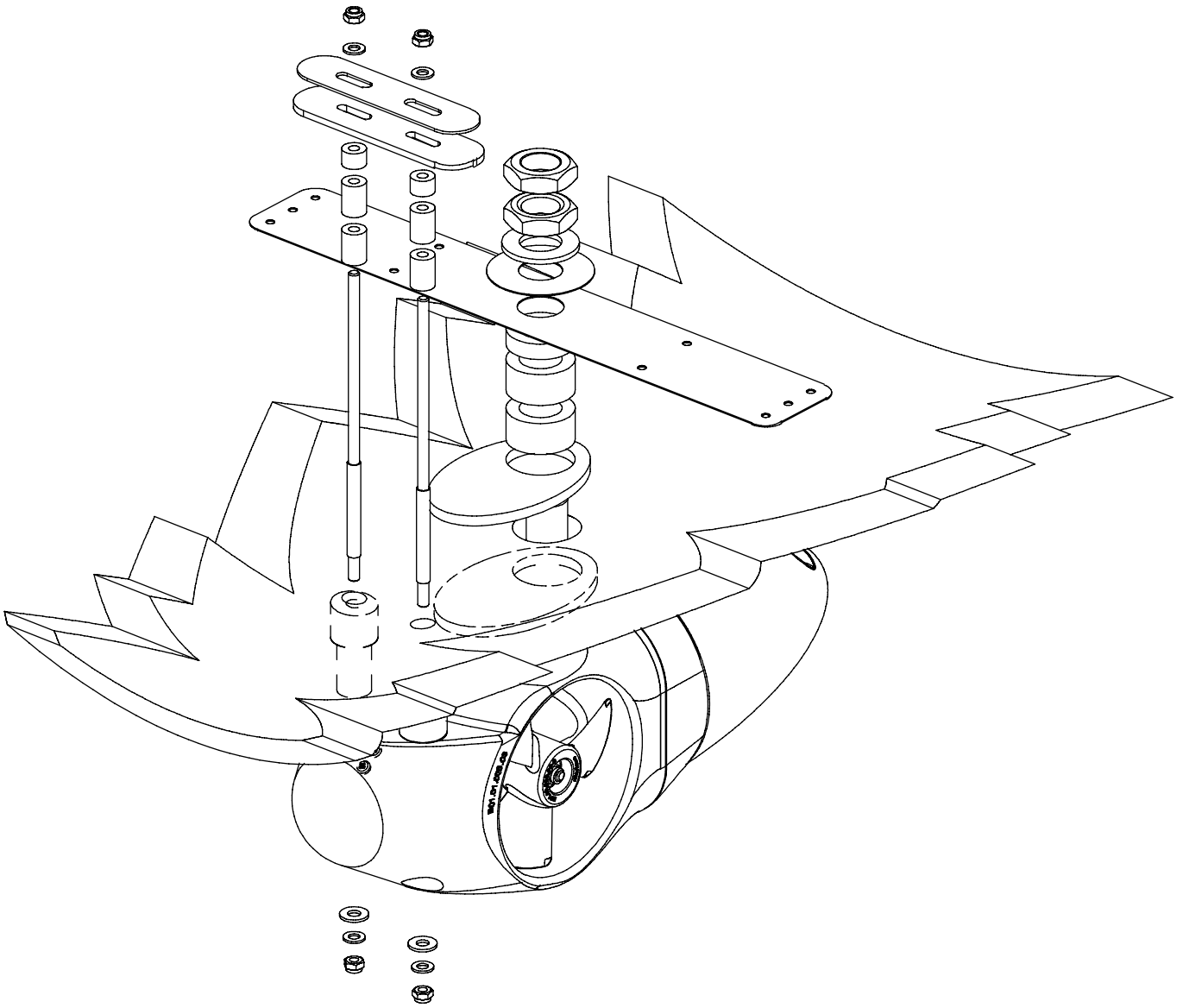

Fig. 16: Mounting „Basic“ on GRP

#### 4.4. Mounting illustration steel and aluminium

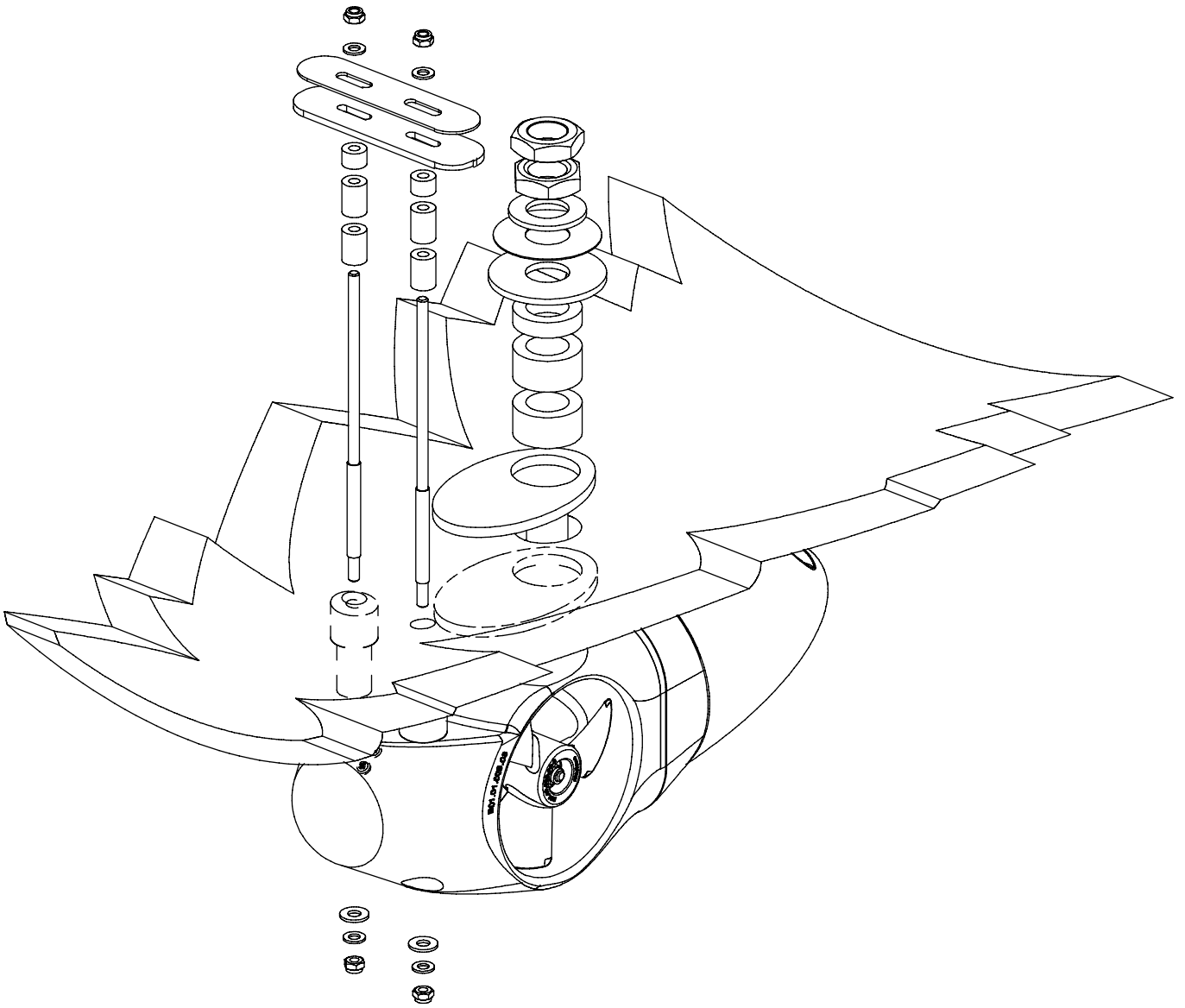

Fig. 17: Mounting „Basic“ on steel and aluminium

## 5. MONUTING KIT ADAPTER

### 5.1. Adapter positioning (round chine)

First plug the adapter (fig. 18) on the thruster and mount it temporary via the main connection. Mark the front boreholes for the mounting bolts.

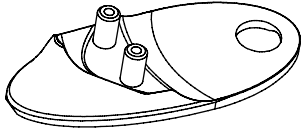

Fig. 18: Adapter

Afterwards turn the thruster with plugged-on adapter to the side and drill the holes for the mounting bolts with diameter 9 mm (on GRP) or 18 mm (on steel or aluminium).



Fig. 19: mounting bolts drilling

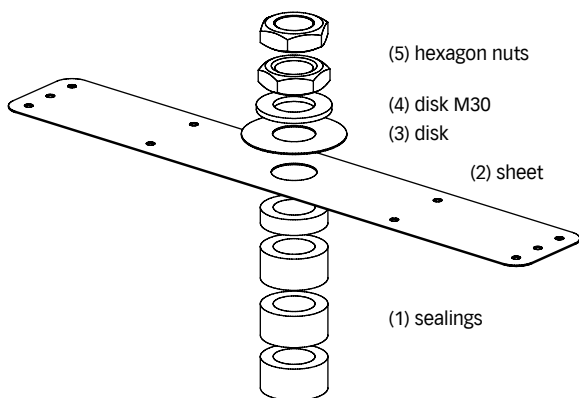

Fig. 20: main connection GRP

**CAUTION!**

On hulls out of steel or aluminium it is compellent to use the isolator instead of the metal sheet!

### 5.2. Bolting and sealing

Bolt down the thruster via the main connection, thereby paying attention to the right number of seals (fig. 10) The sequence corresponds to the one in fig. 20, whereby, depending on the hull thickness, several seals (1) must be used. It is to be considered that those seals are compressed by about 25 % when tightening the bolts (fig. 10).

Ideally, coat the metal sheet (2) at the lower surface with sealant (e.g. Sikaflex). Don't press it to the hull by hand so that the metal sheet can adapt to the hull shape automatically when tightening the bolts. Apply disk (3) and disk M30 (4) and tighten the two hexagon nuts (5) firmly. Thereby the sealings (1) are compressed and fill out the drill hole completely. It is recommended to press against the thruster from the outside to prevent the sealings from being pressed out of the borehole when tightening the bolts. The metal sheet (2) adapts to the hull shape.

On hulls out of steel or aluminium it is compellent to use the isolator instead of the metal sheet (see 5.5. Mounting illustration steel and aluminium)!

Finally screw together the mounting bolts like illustrated in fig. 21 cutting them in the boat interior as necessary. Apply seals (2) according to the hull thickness (note: hull thickness + 25 %). On hulls out of GRP and boreholes of 9 mm the seals (2) can be omitted by using suitable sealant (e.g. Sikaflex).

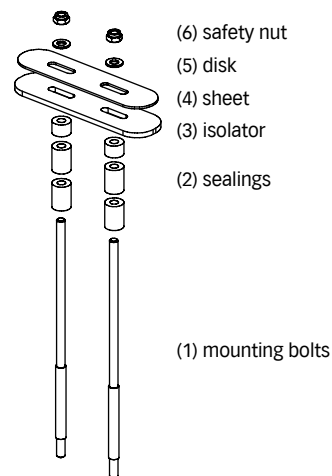

Fig. 21: assembly mounting bolts

Total sealing height for mounting bolts:

**hull thickness x 1,25**

Example: total sealing height with hull thickness 30 mm:

$$30 \times 1,25 = 37,5 \text{ mm}$$

If there remains a gap between adapter and boat hull it is recommended to fill it out with suitable sealant (e.g. Sikaflex).

Note: In order to protect the outside edges of the drill holes, it is recommended to apply a suitable sealant (e.g. Sikaflex).

With the mounting kit "Adapter" on a round chine EXTURN is mountable within one hour (without electrical installation).



Fig. 22: EXTURN mounted with mounting kit „Adapter“

### 5.3. Adapter socket construction (hard chine)

Plug the adapter on a suitable object with diameter 50 mm (e.g. a tube) and insert it (center it) through the already drilled borehole (fig. 23).



Fig. 23: centering adapter

Verify the adapter's symmetrical position (tangential to the boat hull) and fix the adapter temporarily. Now mark the projection of the adapter on the hull (fig. 24).



Fig. 24: projection marking

Grind off the area of the projection up to the glass fibre mat. On hulls out of steel or aluminium eliminate any kind of dirt (color, antifouling) in the area of the projection (fig. 25).



Fig. 25: projection grinded off

Cover the adapter with adhesive tape to prevent it from sticking together with putty and put on plenty of putty suitable for underwater environment.

Center the adapter with the putty coat on the 50 mm borehole, again verify the symmetrical end position and fix it temporarily. Firmly press the adapter on the hull taking care not to deform it!

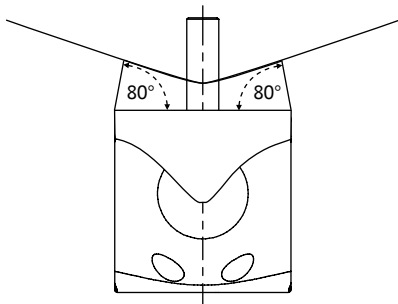

Fig. 26: symmetrical end position

Shape the socket completely with the putty (fig. 27). Only use putty suitable for underwater environment and follow the instructions of the producer by all means. To optimize the spatter behaviour shape the socket in an angle of approx. 80 °!

**CAUTION!**

To optimize the spatter behaviour shape the socket in an angle of approx. 80°!



Fig. 27: socket shaping

After the necessary drying time demount the adapter. The socket must be free of cracks and blowholes, otherwise make the required corrections.



Fig. 28: socket shaped

Grind the socket smooth and lacquer it. If necessary shape a contact surface in the boat interior for the main connection with diameter 50 mm (fig. 29).



Fig. 29: boat interior contact surface



Afterwards prepare the contact surface for the interior bolting of the mounting bolts (fig. 30). Therefore make two drillings of 8 mm in distance of 65 mm.

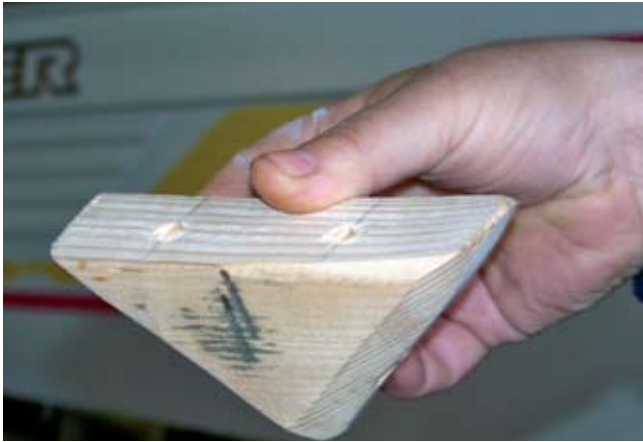

Fig. 30: example timber wedge contact surface

Finally remove the adhesive tape from the adapter, plug the adapter on the thruster and mount it via the main connection and mounting bolts (see 5.2. Bolting and sealing).



Fig. 31: boat interior bolting GRP

For boats without antifouling it is recommended to lacquer EXTURN according to the hull color, for practical reasons before installation. Implicitly follow the instructions of the lacquer producer!

With the mounting kit "Adapter" on a hard chine EXTURN is mountable within five hours (without electrical installation).



Fig. 32: EXTURN lacquered and mounted

#### **CAUTION!**

For boats without antifouling it is recommended to lacquer EXTURN according to the hull color, for practical reasons before installation!

#### **CAUTION!**

Contact between adapter and fuels, oils, greases, solvent naphtha, dissolvers like toluol, dichloromethane, trichloroethane, nitro-cellulose combination thinner or concentrated nitric and sulphuric acid is prohibited!

### 5.4. Mounting illustration GRP

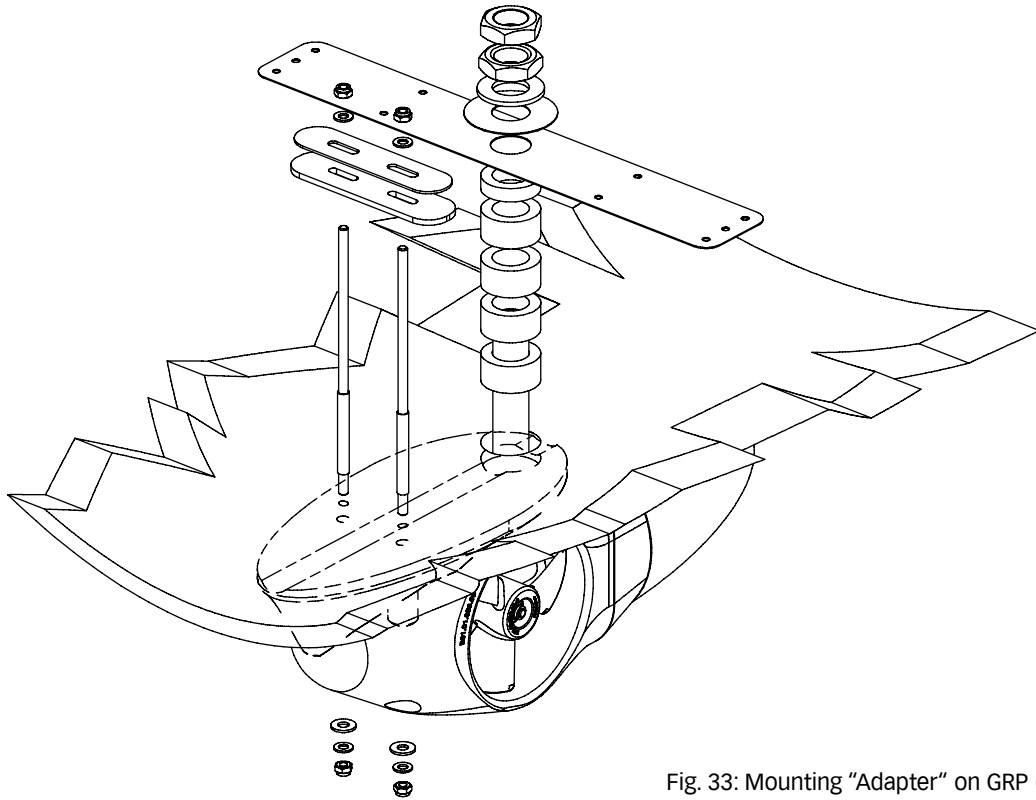

Fig. 33: Mounting "Adapter" on GRP (round chine))

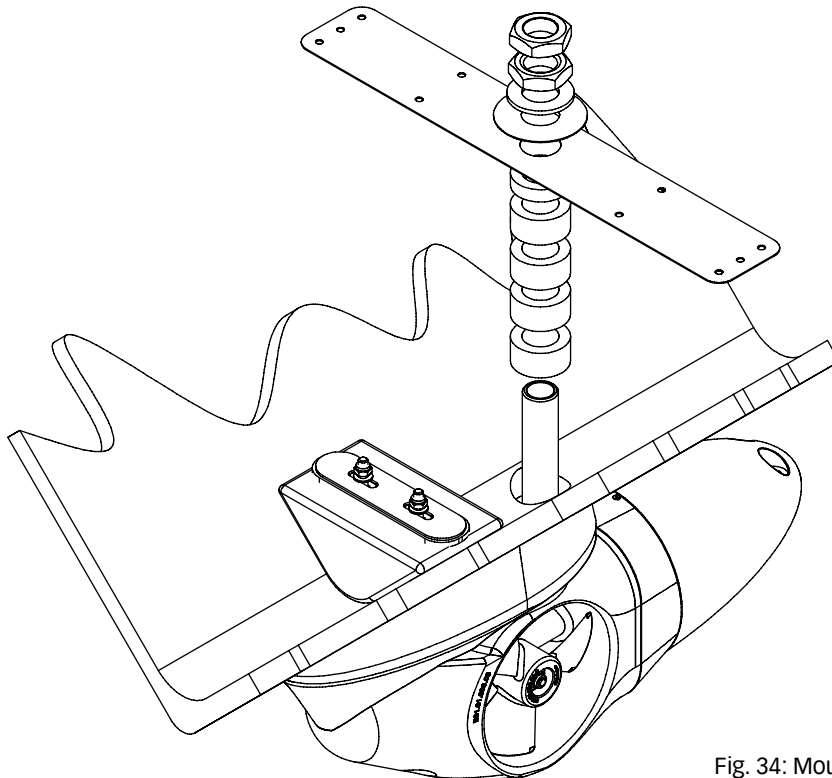

Fig. 34: Mounting "Adapter" on GRP (hard chine)

### 5.5. Mounting illustration steel and aluminium

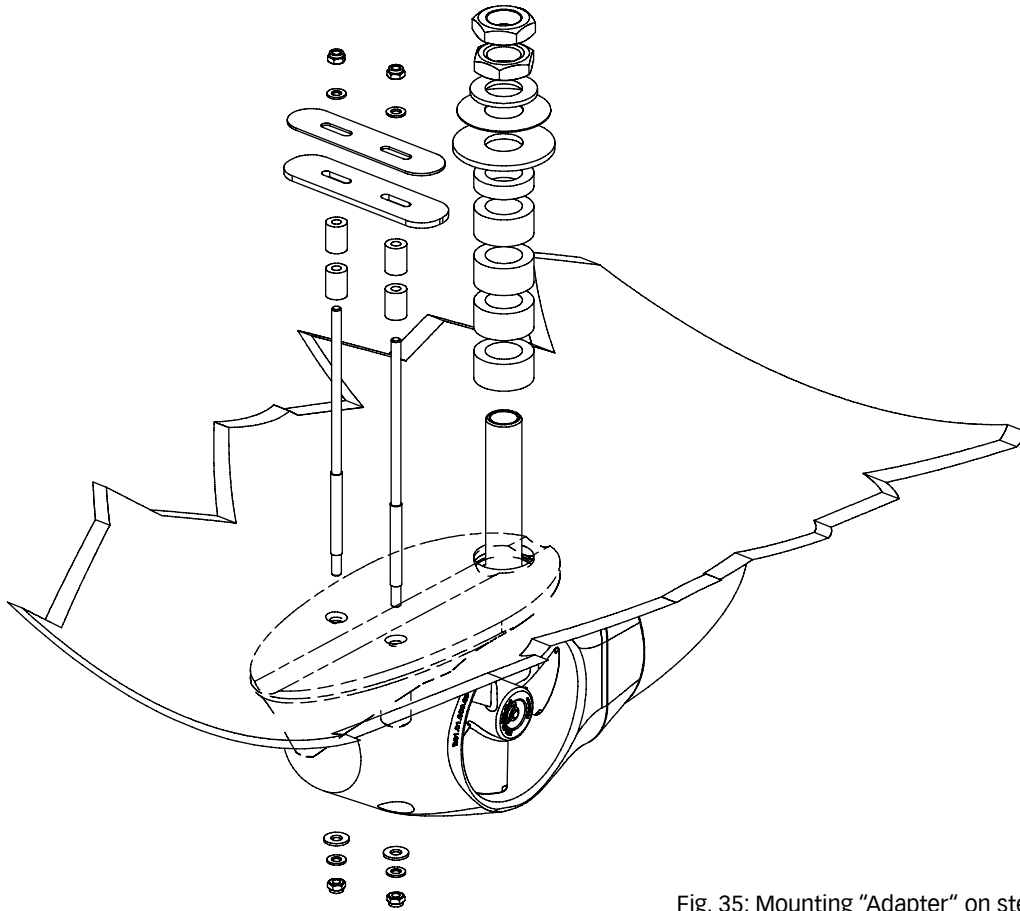

Fig. 35: Mounting "Adapter" on steel and aluminium (round chine)

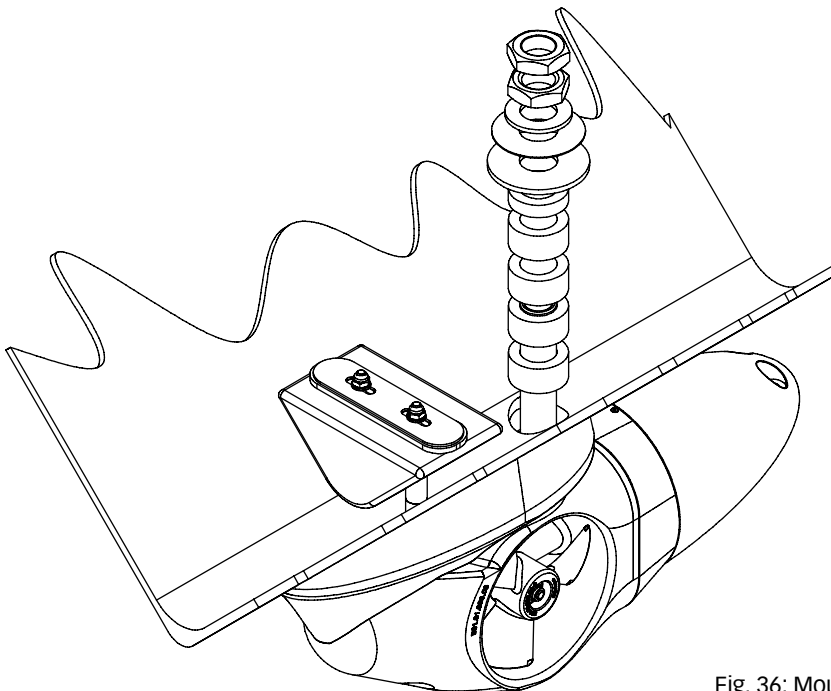

Fig. 36: Mounting "Adapter" on steel and aluminium (hard chine)

## 6. MOUNTING DUPLEX

### 6.1. General Instructions

- The EXTURN Duplex has two motors and therefore is to be handled like two single EXTURNS during mounting.
- The hole center distance of the two hollow shafts has to exactly comply with the dimension sheet (see Dimensions on page 30).
- The mounting surface for the EXTURN Duplex must be in-plane, if necessary a socket has to be developed accordingly (Fig. 37).

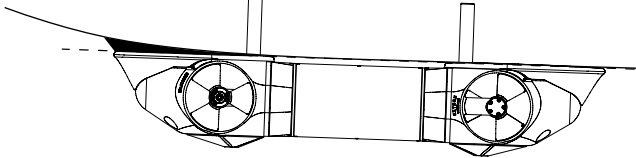

Fig. 37: EXTURN Duplex mounting surface

### 6.2. Measuring of the mounting position

The EXTURN bow and stern thruster must be positioned exactly on the middle line of the boat. In order to determine this, it is recommended to draw a line from the keel to the bow or stern with a cord or a measuring tape and fix it. Subsequently, by means of this line, the desired position can be shifted easily forward or backward.

The EXTURN Duplex requires two holes with a diameter of 50 - 51 mm. The hole center distance has to exactly comply with the dimension sheet (see Dimensions on page 30). Check the distance between the boreholes before drilling!

For the choice of the mounting position, it is to be likewise made certain that the required holes are not drilled at an unsuitable position (e.g. bulkhead). The metal sheets to be used (except on steel and aluminium boats) have a width of 80 mm. So that they can be placed without problems, the boreholes must be at least 60 mm from the next bulkhead.

For the reasons mentioned above, the positioning should be measured exactly in any case before the execution of the drilling, also inside the boat.



Fig. 38: EXTURN Duplex mounted

## 7. ELECTRICAL INSTALLATION

### 7.1. General Instructions

- The electrical installation is principally to be accomplished by a specialist.
- All contacts, plugs and connections must be installed in a way that they always remain dry.
- Main relay and E-BOX must be placed in such a way that they always remain dry.
- All screws must be pulled tight before start-up.

The general instructions refer to EXTURN and also to EXTURN Duplex.

### 7.2. EXTURN Performance Specifications

Model	Power (kW)	Thrust (kgf)	Voltage (V)	Nominal Current (A)
EXTURN 110	1,1	20	12	130
EXTURN 130	1,3	25	12	140
EXTURN 180	1,8	40	12	187
EXTURN 230	2,3	53	24	120
EXTURN 300	3,0	67	24	175
EXTURN 400	4,0	85	12	2x187
EXTURN 600	6,0	120	24	2x175

### 7.3. Fuse protection and wire cross section

Model	Fuse (NH00) (A)	Cross Section 0 - 8 m* (mm <sup>2</sup> )	Cross Section 8 - 16 m* (mm <sup>2</sup> )	Battery recommendation**
EXTURN 110	100	35	70	1x Optima 900 BlueTop - 55 Ah
EXTURN 130	100	35	70	1x Optima 900 BlueTop - 55 Ah
EXTURN 180	125	50	70	1x Optima 900 BlueTop - 55 Ah
EXTURN 230	80	25	50	2x Optima 900 BlueTop - 55 Ah
EXTURN 300	100	50	70	2x Optima 900 BlueTop - 55 Ah
EXTURN 400	2x125	50	70	2x Optima 900 BlueTop - 55 Ah <sup>1</sup>
EXTURN 600	2x125	50	70	4x Optima 900 BlueTop - 55 Ah <sup>2</sup>

\* wire length is the sum of + and - wire.

\*\* The several models have been optimized for a runtime of 10 minutes without recharging.

<sup>1</sup> Optima battery bank (2x Optima 900 BlueTop - 55 Ah, connected parallel) or 1x 100 Ah gel battery

<sup>2</sup> 2x Optima battery bank (2x2 Optima 900 BlueTop - 55 Ah, connected in series) or 2x 100 Ah gel batteries connected in series

## 7.4. Choice of battery

The overall capacity of the battery must be coordinated with the power setting of the respective EXTURN model (see 7.2. EXTURN Performance Specifications and 7.3. Fuse protection and wire cross section). It is recommended to use one or more separate starter batteries (no consumer batteries!) for each EXTURN and to place these as close as possible to the bow or stern thruster to minimise cable length or cable thickness and power losses.

Always use batteries with matching type and capacity!

With the employment of an EXTURN model with 24 V with a board voltage of 12 V, it is recommended to connect two 12 V-batteries in series, in order to achieve the necessary voltage for the bow or stern thruster. A 12 V / 24 V battery charger and voltage converter is available on request.

## 7.5. Wiring

The cable length of EXTURN is 1 m. The main relay should therefore be placed as close as possible to the bow or stern thruster.

The minimum cable diameter is to be coordinated with the power setting of the EXTURN model used (see 7.3. Fuse protection and wire cross section), in order to keep the power loss between battery and bow or stern thruster as low as possible.

In order to protect EXTURN from overloading and to protect the electrical system from short-circuit both a main switch and a protection fuse must be integrated into the positive wiring loom (see 7.3. Fuse protection and wire cross section). The potential equalisation is to be performed like illustrated in the control circuit scheme.

The EXTURN main switch should be installed in an easily accessible place, thus the power for the bow or stern thruster can be switched off in emergencies, without influencing the other electrics on board. With non-operation, the EXTURN main switch should generally be switched off.

## 7.6. Installation of the E-BOX

The E-BOX is the central control element, to which several control panels can be attached. It can be mounted in any position.

The control voltage of the E-BOX is 12 V and must be secured by a 6 A-fuse provided by the customer (e.g. existing electric circuit on board).

The E-BOX has plug-in connections for the following components:

- PANEL 1: joystick or touch panel
- PANEL 2: joystick or touch panel
- RC: remote control receiver
- EXTURN 1: connection for bow or stern thruster
- EXTURN 2: dummy plug (connection for duplex variant)
- POWER: power supply



Fig. 39: E-BOX 103 with dummy plug

All plug-in connectors have an individual shape. Thus, only the respective matching components can be connected.

The EXTURN 2 connection is to be provided with the enclosed dummy plug. The connection between E-Box and main relay is illustrated in the control circuit scheme (see 10.2. or 10.3. for EXTURN and 10.5 or 10.6 for EXTURN Duplex).

Note: It is not possible to operate two EXTURNS independently by means of one E-Box!

### 7.7. Installation of joystick and touch panel (optional)

Select a suitable position for the control element. Joystick or touch panel should be easily attainable and not blocked by other parts.

1. Execute the necessary drillings and cutting out according to the provided template (see 10.9.).
2. Insert panel (1) including the enclosed seal (2) and fasten it with the four provided screws (3).
3. Connect the plug of the control element with the E-BOX, either directly or with the separately available extension cable.
4. Finally, insert the enclosed rubber plugs (4) into the four drill holes.

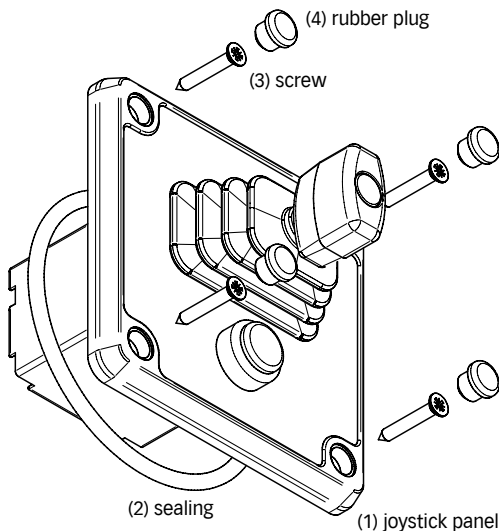

Fig. 40: joystick

### 7.8. Installation of the radio remote control (optional)

Select a suitable position for the remote control receiver. The provided 3 m cable allows variable positioning, so that the optimum receiving place on board can be determined.

1. Attach the four connectors of the cable to the remote control receiver according to the control circuit scheme (see 10.2. or 10.3. for EXTURN and 10.5 or 10.6 for EXTURN Duplex).
2. Connect the plug of the remote control receiver with the E-BOX.



Fig. 41: remote control receiver

### 7.9. Installation of multiple control elements

Up to three control elements can be connected with the E-BOX at the same time. The following variants are possible:

- 2 joystick panels
- 2 touch panels
- 1 joystick and 1 touch panel

plugged in PANEL 1 or PANEL 2, respectively

+ radio remote control connected with RC

If only one control element is needed, the second connector remains unoccupied.

## 8. OPERATION

### 8.1. EXTURN as bow thruster

1. Switch on the EXTURN main switch.
2. Push the button on the control panel. The button is illuminated white, EXTURN is active. If the bow thruster is not operated within 10 minutes, the control light of the push-button goes out, EXTURN is inactive. For reactivation, push the button again.
3. Move the joystick in the respective direction (joystick panel) or push the respective key (touch panel, remote control) in order to manoeuvre the bow in the desired direction:

RED = port  
GREEN = starboard

4. Depending on the speed of the movement, stop steering before reaching the desired goal position, as the bow will move a little more in the chosen direction.
5. If necessary, make yourself familiar with the control of EXTURN on open waters, in order to get a feeling for it.
6. Always turn off the EXTURN main switch when leaving the boat.

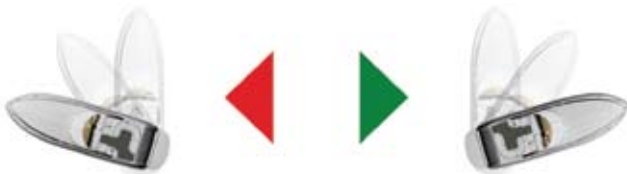

Fig. 42: EXTURN as bow thruster

### 8.2. EXTURN as stern thruster

1. Switch on the EXTURN main switch.
2. Push the button on the control panel. The button is illuminated white, EXTURN is active. If the bow thruster is not operated within 10 minutes, the control light of the push-button goes out, EXTURN is inactive. For reactivation, push the button again
3. Move the joystick in the respective direction (joystick panel) or push the respective key (touch panel, remote control) in order to manoeuvre the bow in the desired direction:

RED = port  
GREEN = starboard

4. Depending on the speed of the movement, stop steering before reaching the desired goal position, as the bow will move a little more in the chosen direction.
5. If necessary, make yourself familiar with the control of EXTURN on open waters, in order to get a feeling for it.
6. Always turn off the EXTURN main switch when leaving the boat.

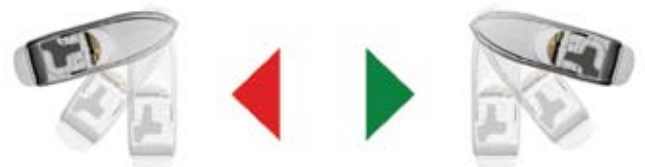

Fig. 43: EXTURN as stern thruster



### 8.3. Bow and stern thrusters combined

The use of both a bow thruster and a stern thruster allows the movement of the boat sideways or turns it around its own axis. It is however necessary to install for both EXTURNS a complete own control unit with main relay, E-BOX and control element (see 7. Electrical Installation).

The operation corresponds to the instructions for EXTURN as bow thruster and EXTURN as stern thruster.



Fig. 44: bow and stern thrusters combined

### 8.4. bow and stern thrusters combined

The E-Box offers the possibility of attaching several control elements (e.g. joystick and touch panel) to the same EXTURN. Thereby, the following function mode is to be considered:

- There can only be one control element active at any time to steer the bow or stern thruster. By pushing the switch-on button at the respective panel, it becomes active (control light on the switch-on button is illuminated white). From this moment on, all other control elements previously activated become inactive (control light on switch-on button goes out).
- The optionally available radio remote control does not have a switch-on button for activation. It is immediately active after pushing one of the two direction keys. From this moment on, all other control elements previously activated become inactive (control light on the switch-on button goes out).

### 8.5. Important User Information

- Don't let EXTURN run outside of the water for more than 5 seconds!
- Do not operate EXTURN outside of the water if there are people near the bow or stern thruster.
- When working on EXTURN (e.g. applying antifouling, replacing the propeller) always switch off the EXTURN main switch.
- If the drive direction of the bow or stern thruster does not correspond to the directions on the control element, wires 1 and 3 at the main relay must be reversed (see 10.2. or 10.3. for EXTURN and 10.5 or 10.6 for EXTURN Duplex).
- EXTURN has a continuous runtime of 3 to 5 minutes depending on the water temperature. Afterwards the overheat protection is activated and the control light on the switch-on button of the control panel begins to flash. After the required cooling time of 5 minutes the control light goes out, EXTURN is ready again for operation.

#### CAUTION!

When the overheat protection is activated the control light on the switch-on button of the control panel begins to flash. After the required cooling time of 5 minutes the control light goes out, EXTURN is ready again for operation.

### 8.6. Maintenance

The EXTURN bow and stern thruster is absolutely maintenance-free. In order to avoid fouling, it is recommended to coat the bow or stern thruster with antifouling. Therefore use an aluminium primer and then the according antifouling.

EXTURN, except of the plastic parts (covers, propeller), is resistant against all prevalent detergents. For cleaning purposes it is recommended to use a high-pressure cleaner. Persistent dirt should be removed by hand brush!

Note: With work on EXTURN (e.g. applying antifouling, changing the propeller) always switch off the EXTURN main switch!

## 8.7. Troubleshooting

The EXTURN bow or stern thruster cannot be started:

- The main switch is not switched on.
- The control panel is inactive.
- The main fuse tripped.
- The control fuse tripped.
- The overtemperature control fuse tripped.

On the control panel the switch-on button control light flashes:

- The overheat protection was activated. A cooling time of 5 minutes is necessary before EXTURN can be operated again.
- EXTURN is not connected with the E-BOX.
- The necessary dummy plug is not correctly attached to the E-BOX.

The EXTURN bow or stern thruster runs in the wrong direction:

- Wires 1 and 3 at the main relay are improperly connected and must be reversed (see 10.2. or 10.3. for EXTURN and 10.5 or 10.6 for EXTURN Duplex).

The EXTURN bow or stern thruster has insufficient power:

- The battery is not sufficiently charged.
- The electrical connections are bad (e.g. because of corrosion).
- The necessary minimum voltage of 10 V or 21 V is not reached.
- The propeller is blocked (e.g. by fouling, wood, line).

## 9. GUARANTEE BOND

1. MARINNO maritime innovations GmbH (in following short: "MARINNO") issues to his customer 3 years guarantee on purchase of an EXTURN bow- and stern thruster (in following short "product"). MARINNO guarantees that the product is free of deficiencies in material and construction.
2. The 3 years term starts on the date of delivery to the end user, at the last on the date of invoice to the end user.
3. In case of deficiency, covered by the guarantee, MARINNO is authorized to choose either to remedy the deficiency himself or by an authorised partner or to replace the defect product by an equal substitute. Replaced spareparts or products become property of MARINNO.
4. Execution of warranty claims is as following:
  - a) Purchaser sends a detailed description of error together with purchase date, purchase place and address of installer to MARINNO or to the local MARINNO distribution partner.
  - b) Purchaser has to bring the product to the place of installer respectively to the local MARINNO distribution partner.
  - c) MARINNO decides within short term, if product will be repaired or replaced.
  - d) In case of replacement MARINNO sends an equal substitute to the local MARINNO distribution partner, who will organise the exchange of the product (for the present installation on charge of the customer) and return the defective product to MARINNO.
  - e) Returned products will be checked immediately in MARINNO's factory. In case of damages due to reasons as per article 5.) the replacement product will be invoiced to the customer. In case of justified guarantee complaint the prepaid installation costs of the replacement product will be credited.
5. Guarantee bonds are not existing in case of malfunction and damage due to faulty installation, inadequate handling and operation, incorrect maintenance, repair or disassembling of the product or adaptation respectively modifications of the product will be credited.
6. Additional claims, especially claims for damages of any kind, do not exist up to this guarantee.
7. Legal obligations, especially warranty claims to seller and possible claims due to the product liability act versus MARINNO as producer are not changed or restricted by this guarantee.

**10. APPENDIX**

**10.1. Dimension sheet EXTURN**

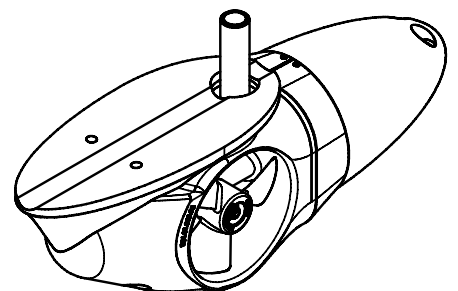
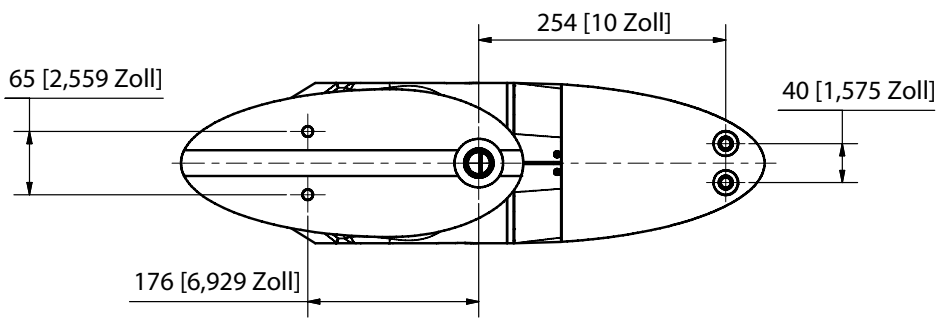
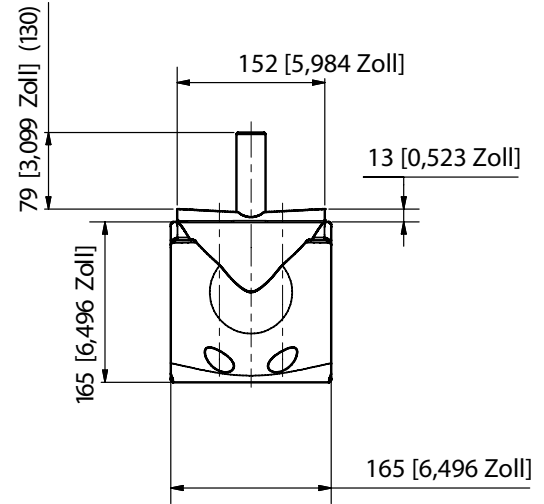
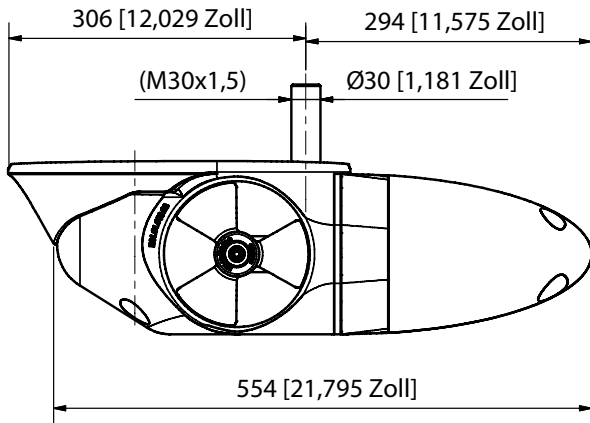

### 10.2. Control Circuit Scheme EXTURN 12 V

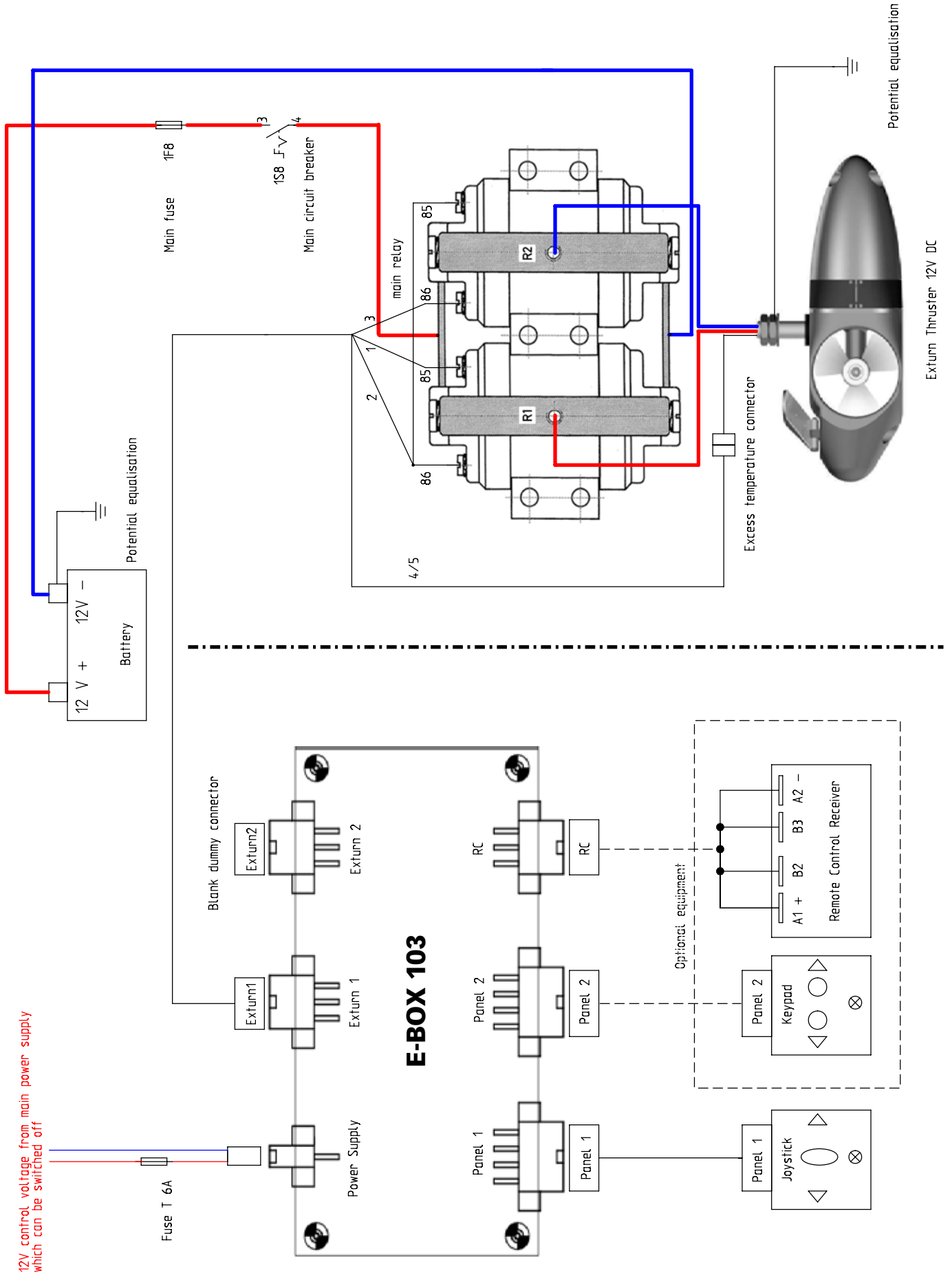

### 10.3. Control Circuit Scheme EXTURN 24 V

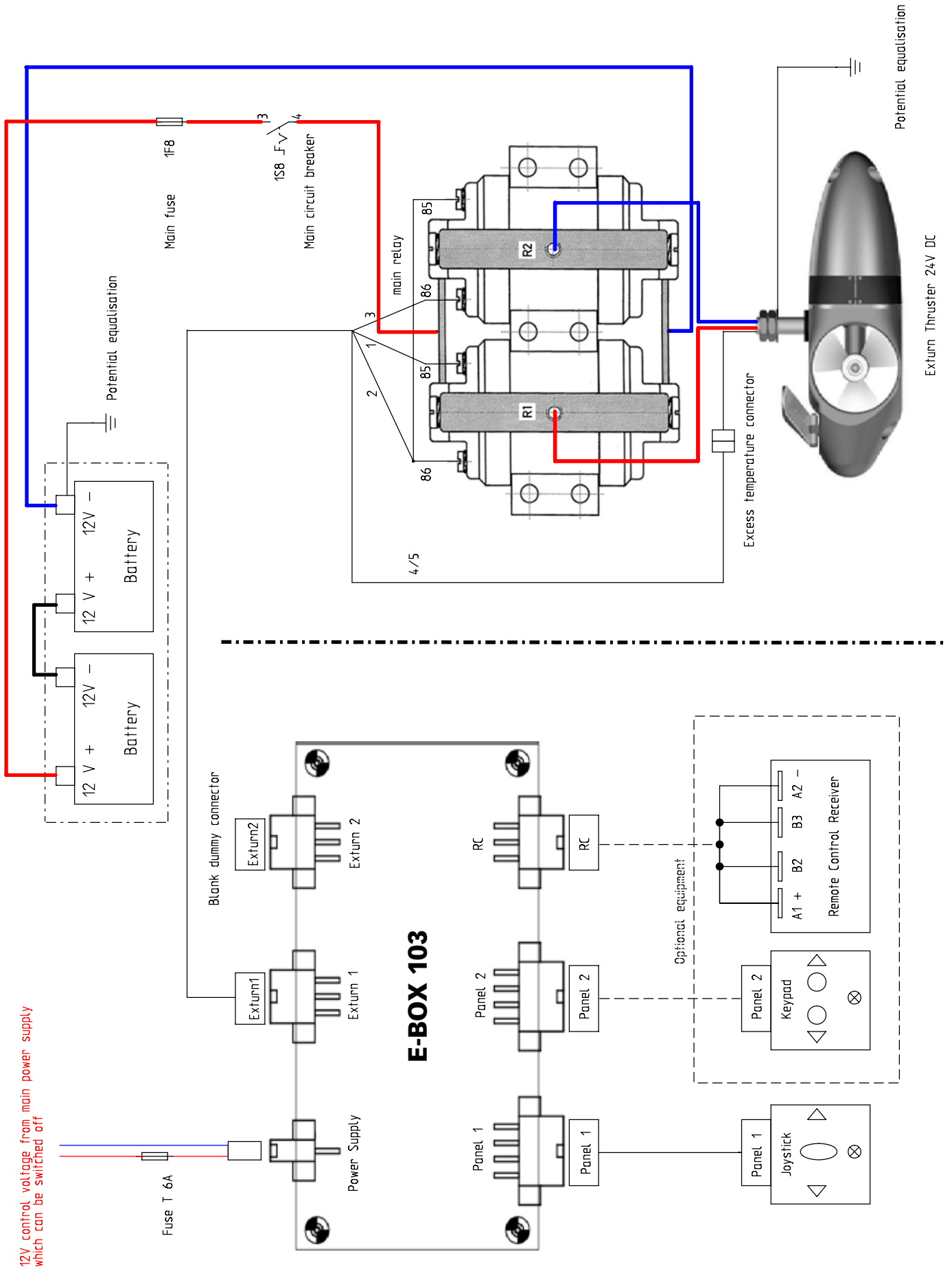

### 10.4. Dimension sheet EXTURN Duplex

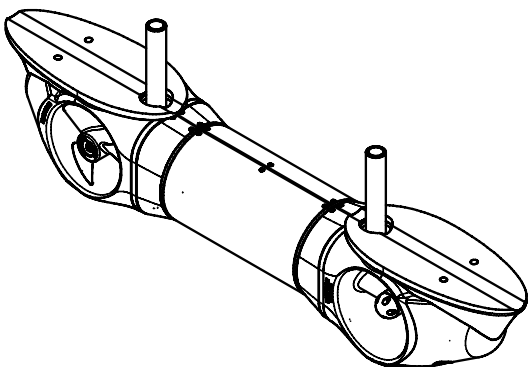
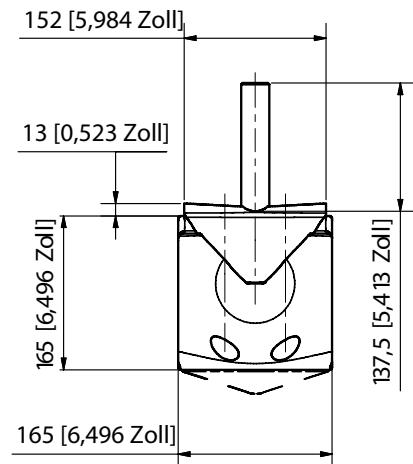
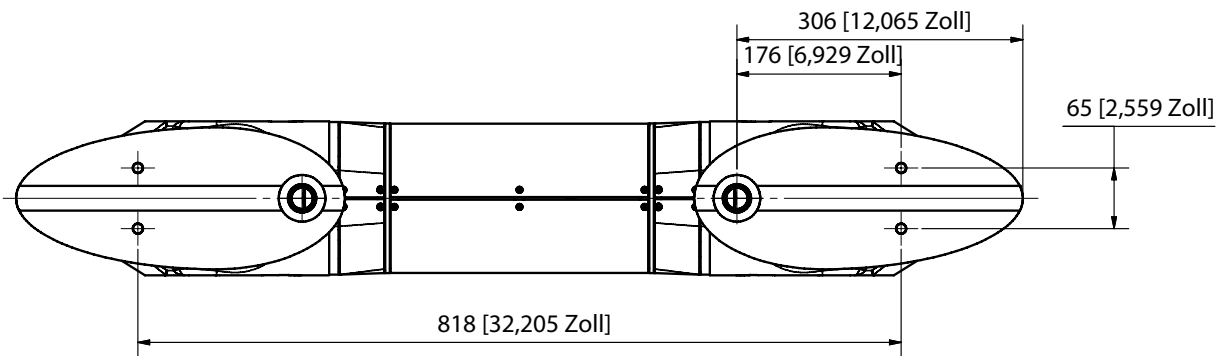
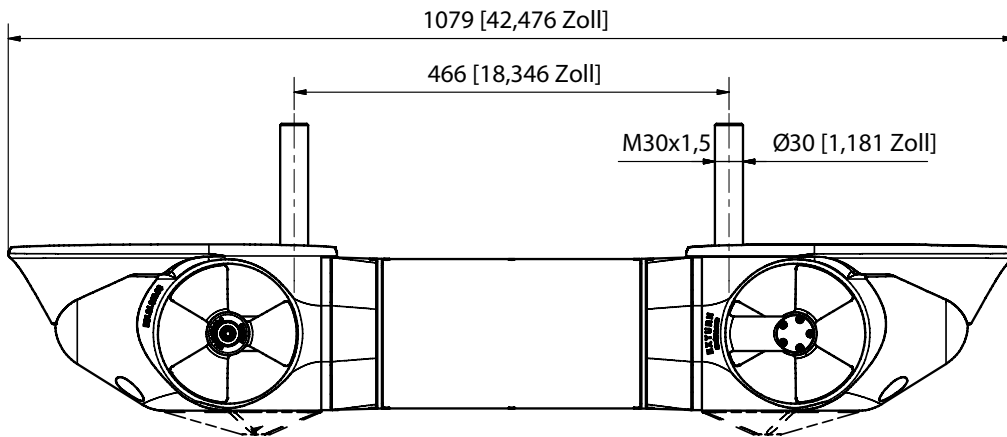

### 10.5. Control Circuit Scheme EXTURN Duplex 600 / 12 V

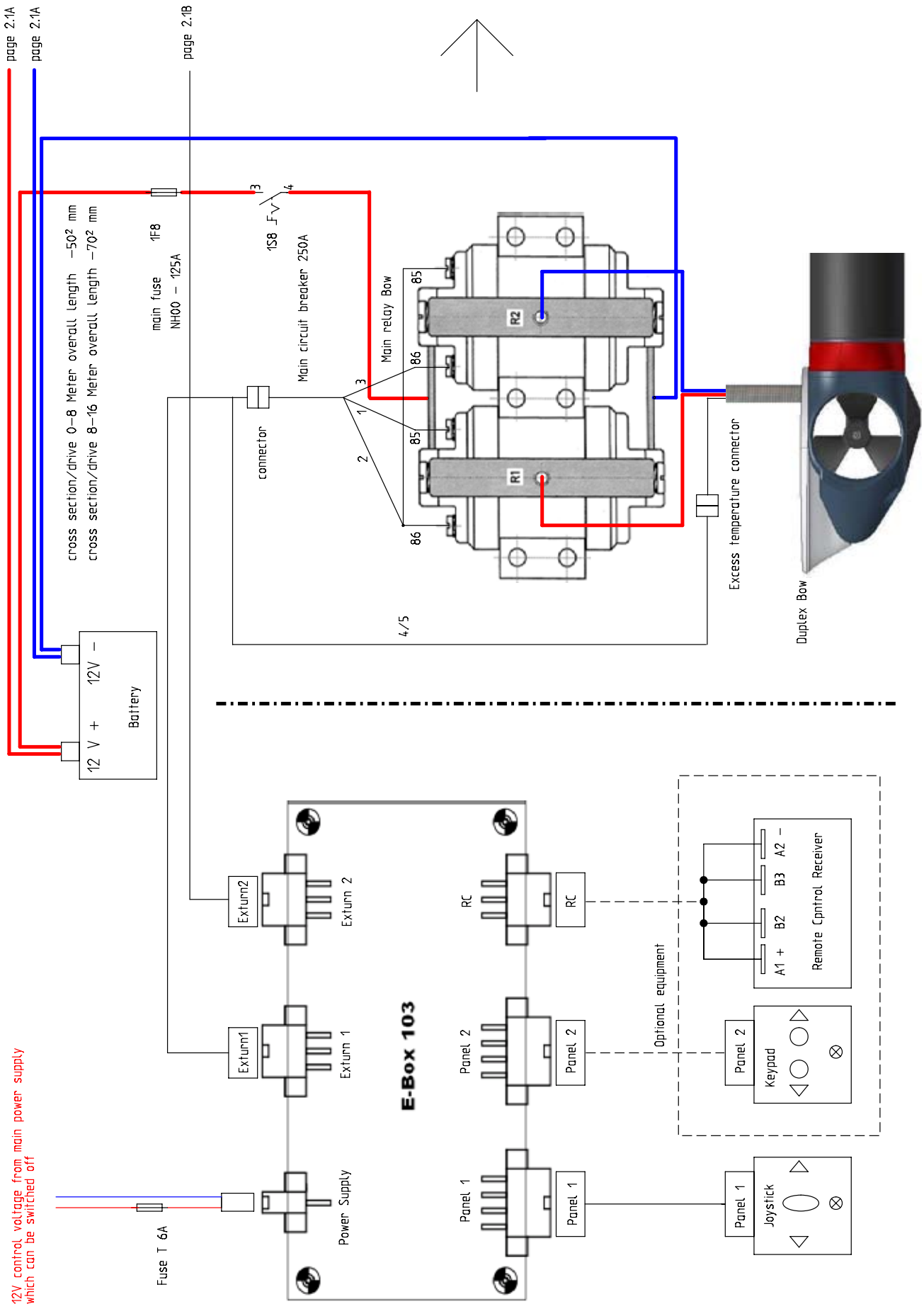

page 1,9A 12V +

page 1,9A 12V -

cross section/drive 0-8 Meter overall length 502 mm  
 cross section/drive 8-16 Meter overall length -702 mm

page 1,9B (Extunn2)

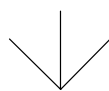
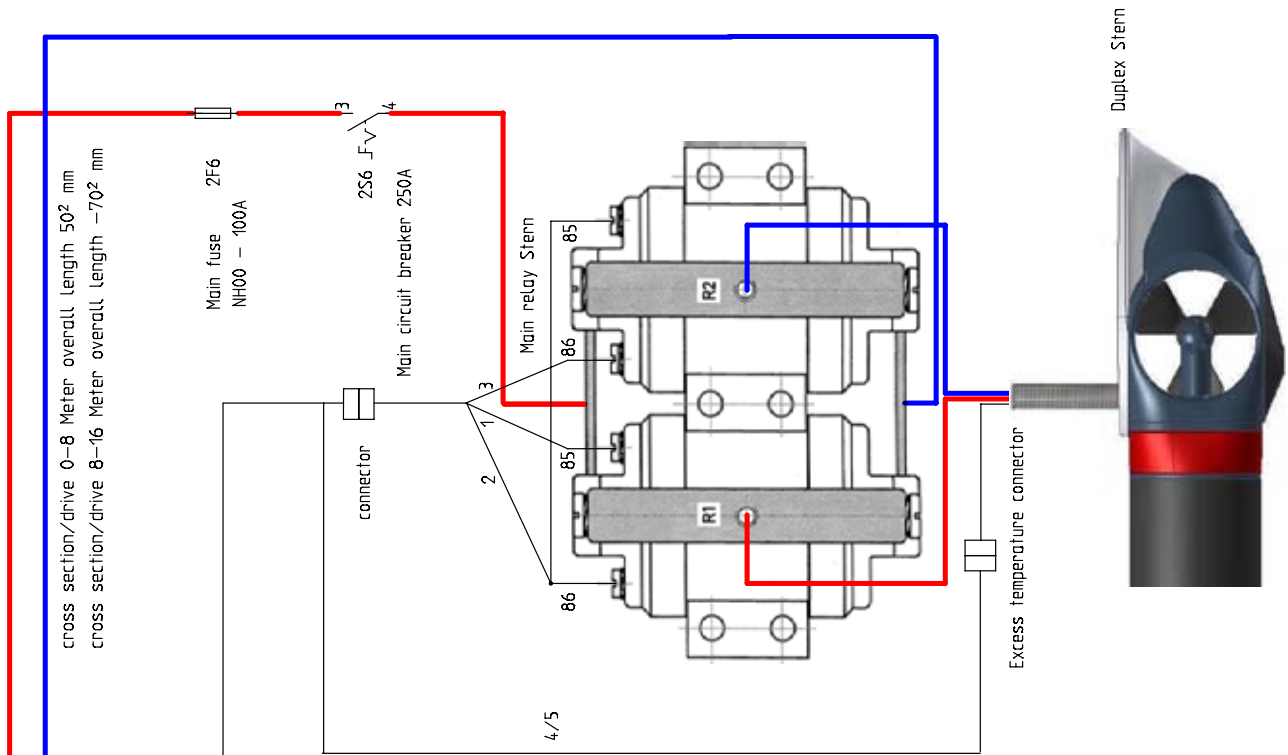



### 10.6. Control Circuit Scheme EXTURN Duplex 400 / 24 V

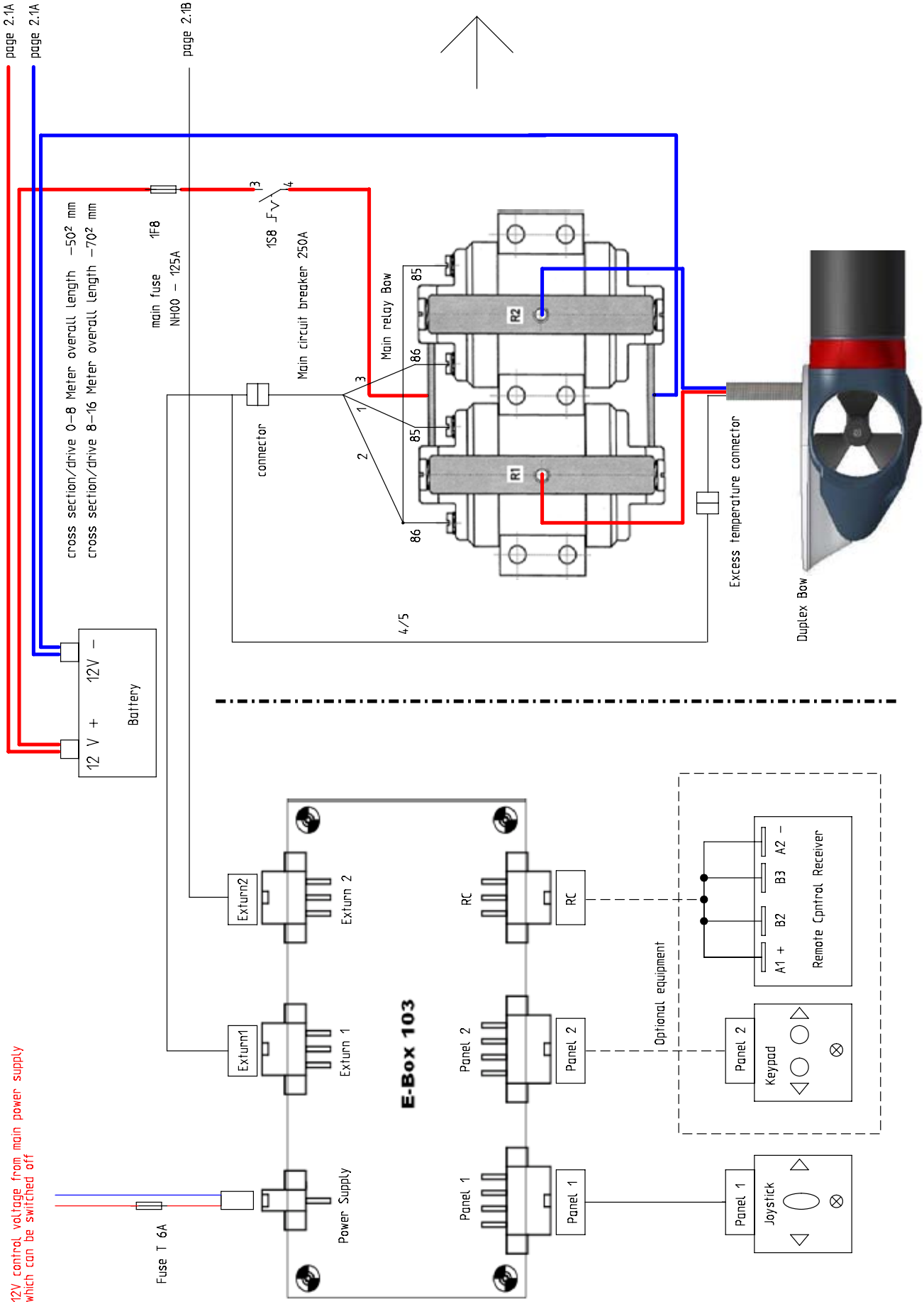

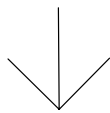
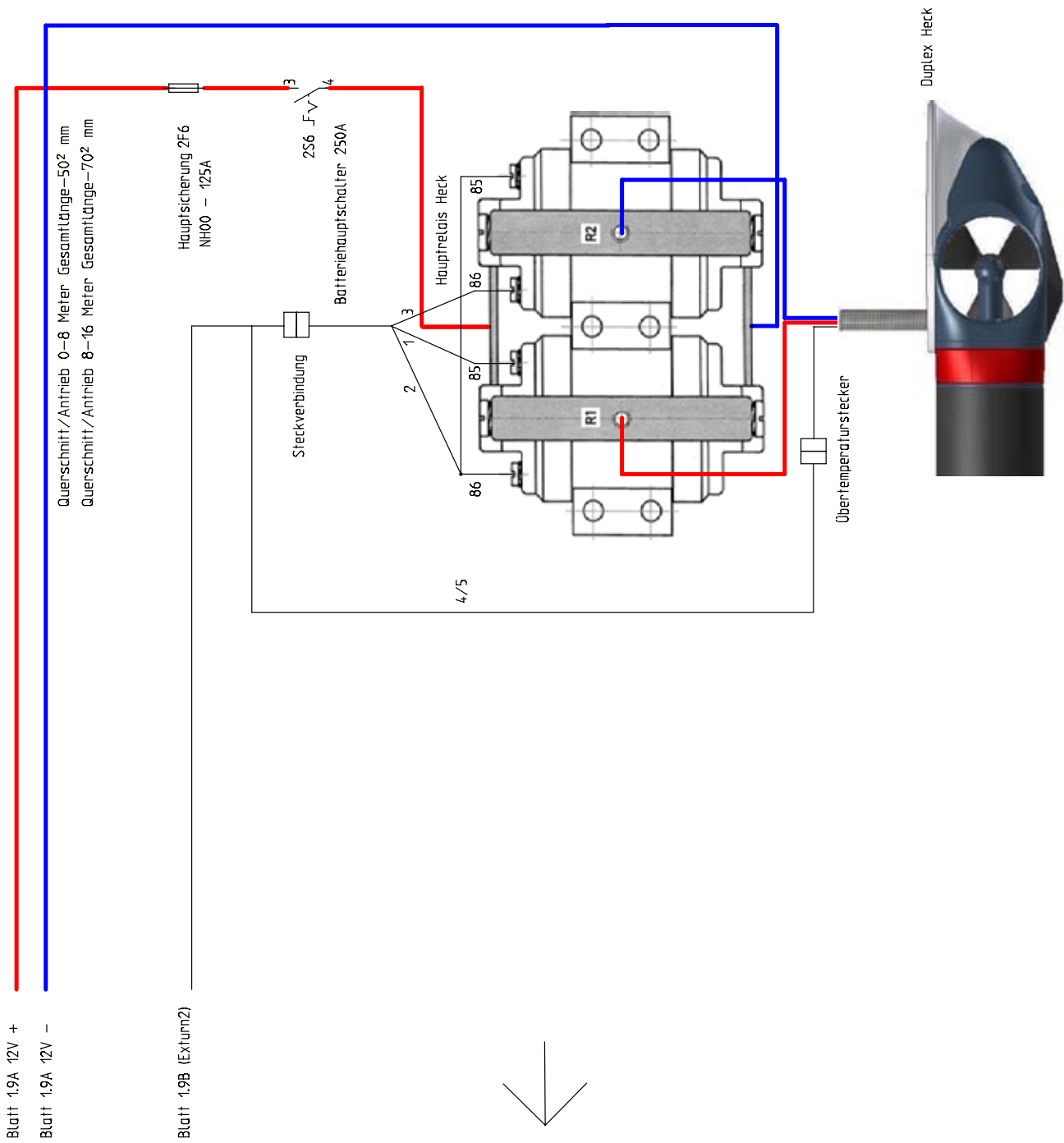

## 10.7. Technical Facts

### EXTURN 110

Power (kW)	1,1
Thrust (kgf)	20
Voltage (V)	12
Nominal Current (A)	130
Length (cm)	55
Weight (kg)	19,5
Diameter (cm)	16,5 x 16,5
Propeller (type)	B010901803-C
recommended boat size (m)	6 - 7,5
recommended boat size (ft.)	20 - 25

### EXTURN 130

Power (kW)	1,3
Thrust (kgf)	25
Voltage (V)	12
Nominal Current (A)	140
Length (cm)	55
Weight (kg)	19,5
Diameter (cm)	16,5 x 16,5
Propeller (type)	B010901803-C
recommended boat size (m)	7 - 9
recommended boat size (ft.)	23 - 30

### EXTURN 180

Power (kW)	1,8
Thrust (kgf)	40
Voltage (V)	12
Nominal Current (A)	187
Length (cm)	55
Weight (kg)	19,5
Diameter (cm)	16,5 x 16,5
Propeller (type)	B010901803-C
recommended boat size (m)	8 - 11
recommended boat size (ft.)	26 - 36

### EXTURN 230

Power (kW)	2,3
Thrust (kgf)	53
Voltage (V)	24
Nominal Current (A)	120
Length (cm)	55
Weight (kg)	19,5
Diameter (cm)	16,5 x 16,5
Propeller (type)	B010903003-C
recommended boat size (m)	10 - 13
recommended boat size (ft.)	33 - 43

### EXTURN 300

Power (kW)	3,0
Thrust (kgf)	67
Voltage (V)	24
Nominal Current (A)	175
Length (cm)	55
Weight (kg)	19,5
Diameter (cm)	16,5 x 16,5
Propeller (type)	B010903003-C
recommended boat size (m)	12 - 15
recommended boat size (ft.)	39 - 49

### EXTURN 400

Power (kW)	4,0
Thrust (kgf)	85
Voltage (V)	12
Nominal Current (A)	374
Length (cm)	98
Weight (kg)	35
Diameter (cm)	16,5 x 16,5
Propeller (type)	2x B010901803-C
recommended boat size (m)	14 - 18
recommended boat size (ft.)	46 - 59

### EXTURN 600

Power (kW)	6,0
Thrust (kgf)	120
Voltage (V)	24
Nominal Current (A)	350
Length (cm)	98
Weight (kg)	35
Diameter (cm)	16,5 x 16,5
Propeller (type)	2x B010903003-C
recommended boat size (m)	17 - 20
recommended boat size (ft.)	56 - 66

## 10.8. Propeller Replacement

The propeller has to be replaced depending on the particular EXTURN model:

- Propeller EXTURN 130/180 (Article No. 50320)
- Propeller EXTURN 230/300 (Article No. 50321)

The space between the plastic disk (2) and the sealing of the housing has to be filled with the enclosed propeller grease (7). It is not necessary to remove pre-existing grease. The space between plastic disk (2) and propeller (4) should not be filled with grease. The thread definitely must stay free from grease.

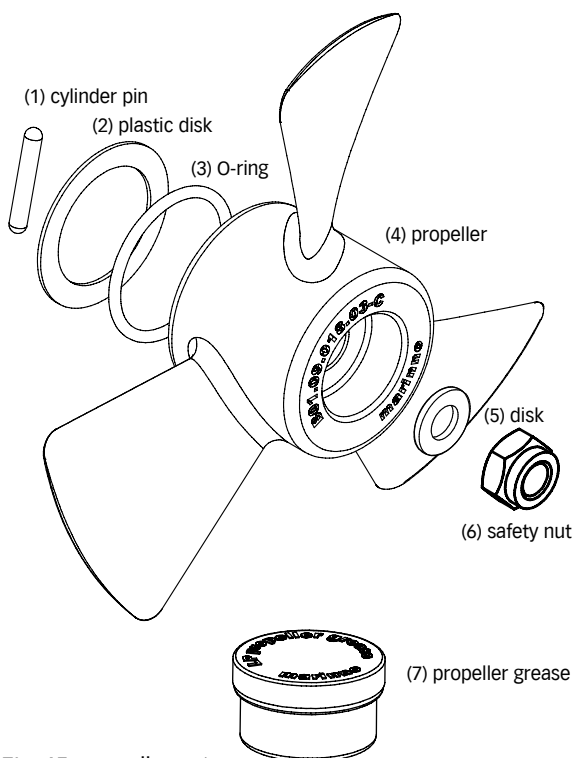

Fig. 45: propeller set

### CAUTION!

During propeller replacement it is compulsory to fill the space between plastic disk and sealing of the housing completely with the enclosed propeller grease!

### CAUTION!

During propeller replacement always switch off the EXTURN main switch!

**10.9. Template for joystick and touch panel**