

# MultiPower

Environment friendly all-in-one hybrid energy

# MultiPower

## The case for a hybrid system

Per Watt AC-power, an inverter is generally more expensive than a generator. So why would one add an inverter to an AC-generator system?

Apart from the obvious advantage of "silent AC-power", there are other major considerations why it is attractive to add a Multi or Quattro inverter/charger to a system with ac-generator:

- More power: generator **plus** inverter instead of generator **or** inverter
- Reduces fuel consumption (and pollution) by a factor three or more
- Cost and time savings as a result of reduced maintenance
- Extended generator life
- 24/7 availability of AC power

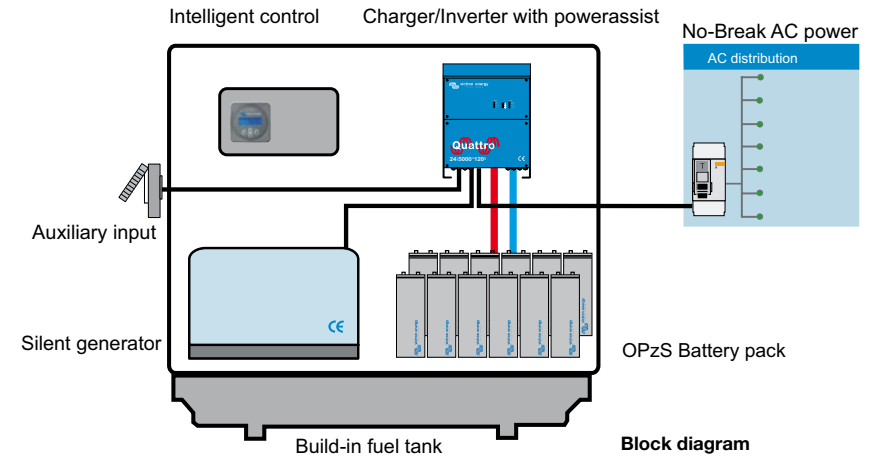
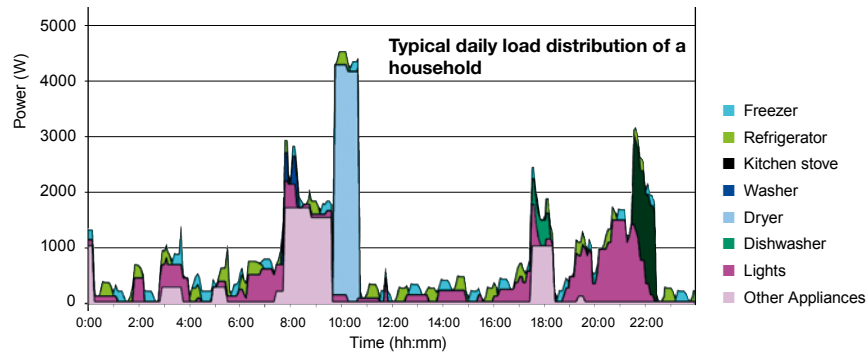

## More power: generator + inverter

The VE Quattro inverter-chargers feature PowerAssist, a unique capability of supplementing power to the generator. Insufficient generator power is immediately compensated for by the inverter/charger with extra power from the battery. The total output power of the system can reach up to 3 times the nominal generator power for temporary heavy loads, and problems related to insufficient generator power are solved once and for all. Electric cooking, washing machines, power tools, water pumping and pressurisation... there are virtually no limitations.

## Fuel savings and less pollution

Tests have shown that a generator is incredibly inefficient when operating at low load. By combining a generator with an inverter/charger and batteries, efficiency can be increased as follows:

- By operating the generator in parallel with the inverter/charger, peak power available is equal to the sum of generator power and inverter power. A smaller generator can therefore be installed.
- When the generator is operating, any available power that is not needed to supply the load will be used to recharge the batteries. The generator will therefore always operate at maximum efficiency.

## Cost and time savings as a result of reduced maintenance, and extended generator life

In most applications the generator, instead of running 24/7, will operate only a few hours per day.

## 24/7 availability of AC power

With AC power available from both the generator and the inverter, the MultiPower has built-in redundancy.

## Preassembled and ready for use

The MultiPower includes all controls for fully automatic operation. Solar or wind power can be added to further reduce generator run hours.



# A few examples of MultiPower configurations

MultiPower	5kVA/600Ah	13kVA/800Ah	18kVA/1000Ah	20kVA/1000Ah	27kVA/1200Ah
Maximum Output	(5kVA inverter)		(Parallel operation of AC generator and Quattro(s))		
Max. output power (kVA / kW)	5 / 4,25	13 / 11	18 / 15	20 / 16	27 / 23
Generator	DC generator		AC generator		
Nominal output voltage	24V DC		230VAC ± 6% single-phase – 50Hz ± 4%		
Continuous output power (kW)	4,8kW/200A DC	7	7	8	10
<b>Output – Inverter mode</b>					
Nominal AC output voltage		230V ± 2% single-phase – 50Hz ± 0.1%			
Cont. output power at 25°C (kVA / kW)	5 / 4,25	5 / 4,25	10 / 8,5	10 / 8,5	15 / 12,75
Cont. output power at 40°C (kW)	3,35	3,35	6,7	6,7	10
Peak power (kW)	7,5	7,5	15	15	22,5
<b>Genset</b>					
Engine (4-stroke direct injection diesel)	Air cooled	Air cooled	Air cooled	Air cooled	Oil cooled
Model	Ruggerini RY 103	Ruggerini RY 125	Ruggerini RY 125	Lombardini 9LD625.2L	Deutz FL2L2011
Cylinders / displacement cm³	1 / 401	1 / 505	1 / 505	2/ 1.248	2 / 1.550
Rating ISO 3046/1 IFN (kW / HP)	6,6 / 9	8,1 / 11	8,1 / 11	10,3 / 14	12,6 / 17
	@3000rpm	@3000rpm	@3000rpm	@1500rpm	@1500rpm
Fuel consumption, nominal load (L/h)	1,6	2,3	2,3	2,7	3,4
Fuel consumption, nominal load (g/kWh)	220	230	230	230	220
Governor type			Mechanical		
Electric start, starter battery, alternator			Standard		
Alternator	DC		SINCRO single-phase AVR regulated		
Model / kW	ET2MCD / 4,8	EK2LBA / 7	EK2LBA / 7	SK160SA1 / 8,2	SK160CB1 / 12,8
Voltage regulation			AVR (electronic voltage regulation)		
<b>Inverter-charger</b>					
Model	Inverter 24/5000		Quattro 24/5000/120 1)		
Configuration	1 unit single	1 unit single	2 units parallel	2 units parallel	3 units parallel
Max. charge current (A)	200	120	120	240	360
<b>Battery</b>					
Type		OPzS flooded tubular plate, 12 cells, 24V			
Cell capacity (Ah @ C10)	600	800	1000	1000	1200
<b>Controls</b>					
Generator controller		Auto/manual start/stop with oil pressure, temperature and voltage protection			
Output voltage indicators		Voltage – Amps – Frequency			
Tank level gauge		Standard			
Hour counter		Standard			
Battery monitor		BMV-600 1)			
External emergency stop button		Standard			
<b>Electrical Connections</b>					
External AC in (grid or emergency)		For external 230V AC source (MCB protected)			
AC out 1		Inverter or/and genset output (MCB protected)			
AC out 2		Genset only output (MCB protected)			
<b>Enclosure</b>					
Common characteristics		Chassis mounted 3-compartment enclosure with lifting ring, designed for outdoor use			
Material, colour		Assembled steel soundproofing enclosure, blue RAL 5012, chassis black			
Access doors		3 doors with single-key locks, left (genset), front (battery), right (inverter-chargers & controls)			
Engine silencer & exhaust		Integrated in enclosure			
Ventilation		Extractor fans in genset and battery compartments, air outlets on back side			
Fuel tank		150L chassis tank			
Dimensions (hxwx d, cm)		174 x 200 x 120			
Approx. weight (excl. Fuel, kg)	1.200	1.500	1.550	1.850	2.000
Approx. noise (open field, dB(A) @ 7m)	65	65	65	65	60

1) for more details on our Quattro Inverter-charger and BMV-600 monitor, please refer to our specific product documentation





**Victron Energy B.V. / De Paal 35**  
1351 JG Almere / The Netherlands

**Phone:** +31 (0)36 535 97 00  
**Fax:** +31 (0)36 535 97 40  
**e-mail:** [sales@victronenergy.com](mailto:sales@victronenergy.com)

[www.victronenergy.com](http://www.victronenergy.com)

## More information

Several downloads are available on our website:

- Victron Marine Generator Test, in particular chapter 4: "The case for a hybrid system"
- "Using the Phoenix MultiPlus to reduce operating cost of a generator"
- "How to reduce the cost of supplying power to an off-grid BTS"

## Configure or assemble your own MultiPower

Please contact us for more information.

