



victron energy
B L U E P O W E R

MANUAL

Quattro 12/5000/200 - 2x30 - 230/240V

Quattro 24/5000/120 - 2x30 - 230/240V

Quattro 48/5000/70 - 2x30 - 230/240V

1. SAFETY INSTRUCTIONS

In general

Please read the documentation supplied with this product first, so that you are familiar with the safety signs and directions before using the product.

This product is designed and tested in accordance with international standards. The equipment should be used for the designated application only.

WARNING: DANGER OF ELECTRICAL SHOCK

The product is used in combination with a permanent energy source (battery). Even if the equipment is switched off, a dangerous electrical voltage can occur at the input and/or output terminals. Always switch the AC power off and disconnect the battery before performing maintenance.

The product contains no internal user-serviceable parts. Do not remove the front panel and do not put the product into operation unless all panels are fitted. All maintenance should be performed by qualified personnel.

Never use the product at sites where gas or dust explosions could occur. Refer to the specifications provided by the manufacturer of the battery to ensure that the battery is suitable for use with this product. The battery manufacturer's safety instructions should always be observed.

WARNING: do not lift heavy objects unassisted.

Installation

Read the installation instructions before commencing installation activities.

This product is a safety class I device (supplied with a ground terminal for safety purposes). **Its AC input and/or output terminals must be provided with uninterruptable grounding for safety purposes. An additional grounding point is located on the outside of the product.** If it can be assumed that the grounding protection is damaged, the product should be taken out of operation and prevented from accidentally being put into operation again; contact qualified maintenance personnel.

Ensure that the connection cables are provided with fuses and circuit breakers. Never replace a protective device by a component of a different type. Refer to the manual for the correct part.

Check before switching the device on whether the available voltage source conforms to the configuration settings of the product as described in the manual.

Ensure that the equipment is used under the correct operating conditions. Never operate it in a wet or dusty environment. Ensure that there is always sufficient free space around the product for ventilation, and that ventilation openings are not blocked. Install the product in a heatproof environment. Ensure therefore that there are no chemicals, plastic parts, curtains or other textiles, etc. in the immediate vicinity of the equipment.

Transport and storage

On storage or transport of the product, ensure that the mains supply and battery leads are disconnected.

No liability can be accepted for damage in transit if the equipment is not transported in its original packaging.

Store the product in a dry environment; the storage temperature should range from -20°C to 60°C .

Refer to the battery manufacturer's manual for information on transport, storage, charging, recharging and disposal of the battery.

2. DESCRIPTION

2.1 In general

The basis of the Quattro is an extremely powerful sine inverter, battery charger and automatic switch in a compact casing. The Quattro features the following additional, often unique characteristics:

Two AC inputs; integrated switch-over system between shore voltage and generating set

The Quattro features two AC inputs (AC-in-1 and AC-in-2) for connecting two independent voltage sources. For example, two generator sets, or a mains supply and a generator set. The Quattro automatically selects the input where voltage is present. If voltage is present on both inputs, the Quattro selects the AC-in-1 input, to which normally the generating set is connected.

Two AC outputs

Besides the usual uninterruptable output, a second output is available that disconnects its load in the event of battery operation. Example: an electrical boiler that is allowed to operate only if the generating set is running or shore voltage is available.

Automatic and uninterruptible switching

In the event of a supply failure or when the generating set is switched off, the Quattro will switch over to inverter operation and take over the supply of the connected devices. This is done so quickly that operation of computers and other electronic devices is not disturbed (Uninterruptible Power Supply or UPS functionality). This makes the Quattro highly suitable as an emergency power system in industrial and telecommunication applications. The maximum alternating current that can be switched is 30A.

Virtually unlimited power thanks to parallel operation

Up to 6 Quattro's can operate in parallel. Six units 24/5000/120, for example, will provide 25kW / 30kVA output power and 720 Amps charging capacity.

Three phase capability

Three units can be configured for three-phase output. But that's not all: up to 6 sets of three units can be parallel connected to provide 75kW / 90kVA inverter power and more than 2000A charging capacity.

PowerControl – maximum use of limited shore current

The Quattro can supply a huge charging current. This implies heavy loading of the shore connection or generating set. For both AC inputs, therefore, a maximum current can be set. The Quattro then takes other power users into account, and only uses 'surplus' current for charging purposes.

- Input AC-in-1, to which usually a generating set is connected, can be set to a fixed maximum with DIP switches, with VE.Net or with a PC, so that the generating set is never overloaded.
- Input AC-in-2 can also be set to a fixed maximum. In mobile applications (ships, vehicles), however, a variable setting by means of a Phoenix Multi Control Panel will usually be selected. In this way the maximum current can be adapted to the available shore current in an extremely simple manner.

PowerAssist – Extended use of your generating set and shore current: the Quattro “co-supply” feature

The Quattro operates in parallel with the generating set or the shore connection. A current shortfall is automatically compensated: the Quattro draws extra power from the battery and helps along. A current surplus is used to recharge the battery.

This unique feature offers a definitive solution for the 'shore current problem': dish washers, washing machines, electric cooking etc. can all run on 16A shore current, or even less. In addition, a smaller generating set can be installed.

Solar energy

The Quattro is extremely suitable for solar energy applications. It can be used for building autonomous systems as well as mains-coupled systems.

Emergency power or autonomous operation on mains failure

Houses or buildings provided with solar panels or a combined micro-scale heating and power plant (a power-generating central heating boiler) or other sustainable energy sources have a potential autonomous energy supply which can be used for powering essential equipment (central heating pumps, refrigerators, deep freeze units, Internet connections, etc.) during a power failure. A problem in this regard, however, is that mains-coupled solar panels and/or micro-scale heating and power plants drop out as soon as the mains supply fails. With a Quattro and batteries, this problem can be solved in a simple manner: **the Quattro can replace the mains supply during a power failure.** When the sustainable energy sources produce more power than necessary, the Quattro will use the surplus to charge the batteries; in the event of a shortfall, the Quattro will supply additional power from its battery energy resources.

Multi-functional relay

The Quattro is equipped with a multi-functional relay that by default is programmed as an alarm relay. The relay can be programmed for all kinds of other applications however, for example as a starter relay for a generating set.

Programmable with DIP switches, VE.Net panel or personal computer

The Quattro is supplied ready for use. Three features are available for changing certain settings if desired:

- The most important settings (including parallel operation of up to three devices and 3-phase operation) can be changed in a very simple manner, using Quattro DIP switches.
- All settings, with exception of the multi-functional relay, can be changed with a VE.Net panel.
- All settings can be changed with a PC and free of charge software, downloadable from our website www.victronenergy.com

2.2 Battery charger

Adaptive 4-stage charging characteristics: bulk – absorption – float – storage

The microprocessor-driven adaptive battery management system can be adjusted for various types of batteries. The adaptive function automatically adapts the charging process to battery use.

Correct charging quantity: adapted absorption time

In the event of slight battery discharge, absorption is kept short to prevent overcharging and excessive gas formation. After deep discharging, the absorption time is automatically extended in order to charge the battery fully.

Limiting aging by excessive gas formation: limited voltage rise

If a high charging current as well as an increased charging voltage is used to shorten charging time, the Quattro will limit the voltage slew rate after the gas pressure has been reached. In this way, excessive gas formation in the final stage of the charging cycle is prevented.

Less maintenance and ageing when the battery is not used: the storage feature

The Quattro switches over to 'storage' if no discharge has occurred after more than 24 hours. The voltage is then lowered to 2.2 V/cell (13.2 V for a 12 V battery). Gas formation in the battery will then be drastically reduced, and corrosion of the positive plates is limited as much as possible. Once a week, the voltage is increased to absorption level to recharge the battery; this prevents stratification of the electrolyte and sulphate formation.

Two DC outputs for charging two batteries

The Quattro has two DC outputs, one of which can supply the full output current. The second output, intended for charging a starter battery, is limited to 4A and has a slightly lower output voltage.

Increasing the lifecycle of the accumulator battery: temperature compensation

The Quattro is supplied with a temperature sensor. The temperature sensor serves to reduce charging voltage when battery temperature rises. This is particularly important for maintenance-free batteries, which could otherwise dry out by overcharging.

Battery voltage sense

In order to compensate for voltage loss due to cable resistance, the Quattro/ Quattro is provided with a voltage sense facility so that the battery always receives the correct charge voltage.

More on batteries and charging

Our book 'Energy Unlimited' offers further information on batteries and battery charging, and is available free of charge at Victron Energy (see www.victronenergy.com). For more information on adaptive charging characteristics, please refer to the 'Tech Info' page on our website.

3. Operation

3.1 “On / stand by / charger only” switch

When the switch is switched to “on”, full device operation is initiated. The inverter will turn on, and the “inverter on” LED will light.

230/240VAC applied to the AC-in-1 or AC-in-2 connection will be switched through to the AC-out-1 and AC-out-2 connections. The inverter is switched off, the “mains on” LED will light and charger operation will be initiated. Depending on the applicable charging mode at that time, the “bulk”, “absorption” or “float” LED will light.

If the voltage on both AC-in connections is rejected, the inverter will be switched on.

If the switch is set to “charger only”, the inverter will not turn on in the event of AC supply failure. Thus the batteries will not be discharged by the inverter.

3.2 Remote control

Remote control is possible with a simple 3-way switch or with a Multi Control panel.

The Quattro Control panel has a simple rotary knob with which the maximum current of the AC-in-2 input can be set: see PowerControl and PowerAssist in Section 2.

3.3 Equalisation and forced absorption

3.3.1 Equalisation

Traction batteries require regular additional charging. In the equalisation mode, the Quattro will charge with increased voltage for one hour (1V above the absorption voltage for a 12V battery, 2V for a 24V battery). The charging current is then limited to 1/4 of the set value. **The “bulk” and “absorption” LEDs flash intermittently.**



Equalisation mode supplies a higher charging voltage than most DC consuming devices can cope with. These devices must be disconnected before additional charging takes place.

3.3.2 Forced absorption

Under certain circumstances, it can be desirable to charge the battery for a fixed time at absorption voltage level. In Forced Absorption mode, the Quattro will charge at the normal absorption voltage level during the set maximum absorption time. **The “absorption” LED lights.**

3.3.3 Activating equalisation or forced absorption

The Quattro can be put into both these states from the remote panel as well as with the front panel switch, provided that all switches (front, remote and panel) are set to “on” and no switches are set to “charger only”.

In order to put the Quattro in this state, the procedure below should be followed.

NOTE: Switching from “on” to “charger only” and vice versa, as described below, must be done quickly. The switch must be turned such that the intermediate position is ‘skipped’, as it were. If the switch concerned remains in the “off” position even for a short time, the device may be turned off. In that case, the procedure must be restarted at step 1. A certain degree of familiarisation is required when using the front switch in particular. When using the remote panel, this is less critical.

1. Check whether all switches (i.e. front switch, remote switch or remote panel switch if present) are in the “on” position.
2. Activating equalisation or forced absorption is only meaningful if the normal charging cycle is completed (charger is in ‘Float’). Set the switch to “charger only”, “on” and “charger only” in rapid succession. NOTE: the switching operation itself must be done quickly, but the time between switching must lie between 1/2 second and 2 seconds.
3. The “bulk”, “absorption” and “float” LEDs will now flash five times. Subsequently, the “bulk”, “absorption” and “float” LEDs will each light for 2 seconds.
 - If switch is set to “on” while the “bulk” LED lights, the charger will be put into equalisation operation.
 - If switch is set to “on” while the “absorption” LED lights, the charger will be put into forced absorption operation.

If the switch is not in the required position after following this procedure, it can be switched over quickly once. This will not change the charging state.

3.4 LED indications and their meaning

- LED off
- LED flashes
- LED lights

Inverter

charger		inverter	
<input type="radio"/> mains on	<input type="radio"/> on	<input checked="" type="radio"/> inverter on	
<input type="radio"/> bulk	<input checked="" type="radio"/> off	<input type="radio"/> overload	
<input type="radio"/> absorption	<input type="radio"/> charger only	<input type="radio"/> low battery	
<input type="radio"/> float		<input type="radio"/> temperature	

The inverter is on, and supplies power to the load.

charger		inverter	
<input type="radio"/> mains on	<input type="radio"/> on	<input checked="" type="radio"/> inverter on	
<input type="radio"/> bulk	<input checked="" type="radio"/> off	<input checked="" type="radio"/> overload	
<input type="radio"/> absorption	<input type="radio"/> charger only	<input type="radio"/> low battery	
<input type="radio"/> float		<input type="radio"/> temperature	

The nominal power of the inverter is exceeded. The "overload" LED flashes.

charger		inverter	
<input type="radio"/> mains on	<input type="radio"/> on	<input type="radio"/> inverter on	
<input type="radio"/> bulk	<input checked="" type="radio"/> off	<input checked="" type="radio"/> overload	
<input type="radio"/> absorption	<input type="radio"/> charger only	<input type="radio"/> low battery	
<input type="radio"/> float		<input type="radio"/> temperature	

The inverter is switched off due to overload or short circuit.

charger		inverter	
<input type="radio"/> mains on	<input type="radio"/> on	<input checked="" type="radio"/> inverter on	
<input type="radio"/> bulk	<input checked="" type="radio"/> off	<input type="radio"/> overload	
<input type="radio"/> absorption	<input type="radio"/> charger only	<input checked="" type="radio"/> low battery	
<input type="radio"/> float		<input type="radio"/> temperature	

The battery is almost empty.

charger		inverter	
<input type="radio"/> mains on	<input type="radio"/> on	<input type="radio"/> inverter on	
<input type="radio"/> bulk	<input checked="" type="radio"/> off	<input type="radio"/> overload	
<input type="radio"/> absorption	<input type="radio"/> charger only	<input checked="" type="radio"/> low battery	
<input type="radio"/> float		<input type="radio"/> temperature	

The inverter is switched off due to low battery voltage.

charger		inverter	
<input type="radio"/> mains on	on	<input checked="" type="radio"/> inverter on	
<input type="radio"/> bulk	 off	<input type="radio"/> overload	
<input type="radio"/> absorption		<input type="radio"/> low battery	
<input type="radio"/> float	charger only	<input checked="" type="radio"/> temperature	

The internal temperature is reaching a critical level.

charger		inverter	
<input type="radio"/> mains on	on	<input type="radio"/> inverter on	
<input type="radio"/> bulk	 off	<input type="radio"/> overload	
<input type="radio"/> absorption		<input type="radio"/> low battery	
<input type="radio"/> float	charger only	<input checked="" type="radio"/> temperature	

The inverter is switched off due to excessively high internal temperature.

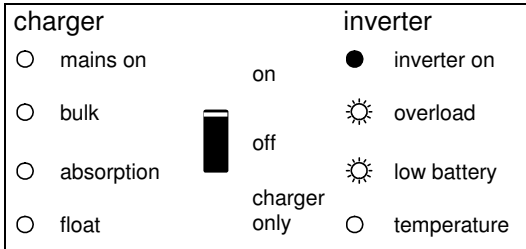

– If the LEDs flash alternately, the battery almost empty and nominal power is exceeded.
 – If “overload” and “low battery” flash simultaneously, there is an excessively high ripple voltage at the battery connection.

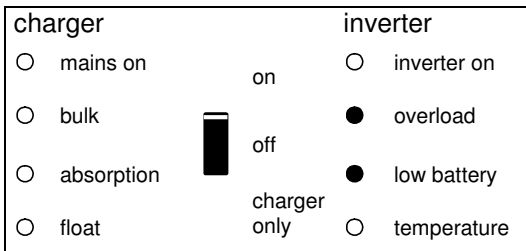

The inverter is switched off due to an excessively high ripple voltage on the battery connection.

Battery charger

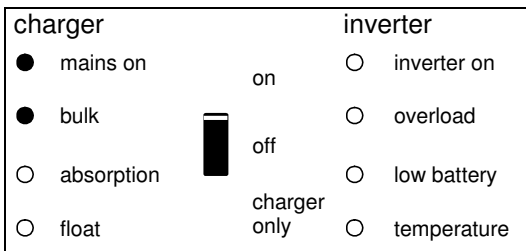

The AC voltage on AC-in-1 or AC-in-2 is switched through, and the charger operates in bulk phase.

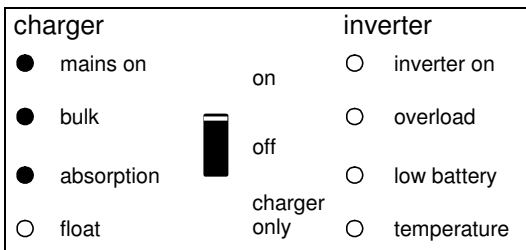

The AC voltage on AC-in-1 or AC-in-2 is switched through and the charger operates, but the set absorption voltage has not yet been reached (battery protection mode)

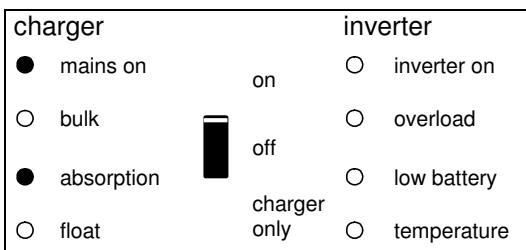

The AC voltage on AC-in-1 or AC-in-2 is switched through, and the charger operates in absorption phase.

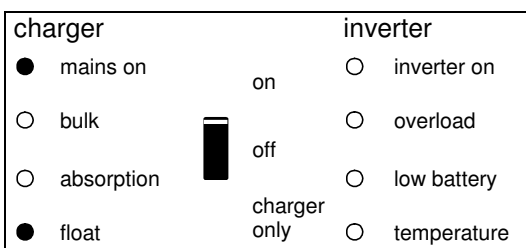

The AC voltage on AC-in-1 or AC-in-2 is switched through, and the charger operates in float or storage phase.

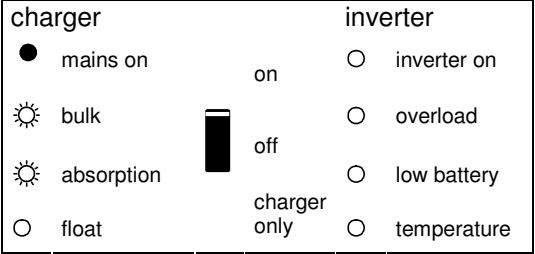

The AC voltage on AC-in-1 or AC-in-2 is switched through, and the charger operates in equalisation mode.

Special indications

Set with limited input current

charger		inverter	
<input checked="" type="radio"/> mains on	on	<input type="radio"/> inverter on	
<input type="radio"/> bulk	 off	<input type="radio"/> overload	
<input type="radio"/> absorption		<input type="radio"/> low battery	
<input type="radio"/> float	charger only	<input type="radio"/> temperature	

The AC voltage on AC1-in-1 or AC-in-2 is switched through. The AC-input current is equal to the load current. The charger is down-controlled to 0A.

Set to supply additional current

charger		inverter	
<input checked="" type="radio"/> mains on	on	<input checked="" type="radio"/> inverter on	
<input type="radio"/> bulk	 off	<input type="radio"/> overload	
<input type="radio"/> absorption		<input type="radio"/> low battery	
<input type="radio"/> float	charger only	<input type="radio"/> temperature	

The AC voltage on AC-in-1 or AC-in-2 is switched through, but the load demands more current than the mains can supply. The inverter is now switched on to supply additional current.

4. Installation



This product may only be installed by a qualified electrical engineer.

4.1 Contents of the box

The Quattro box contains the following:

- Quattro inverter/battery charger
- User manual
- Installation manual
- Suspension bracket
- Temperature sensor
- Warning sticker for battery charging
- Four fixing screws

4.2 Location

The Quattro should be installed in a dry, well-ventilated location, as close as possible to the batteries. The device should be surrounded by a free space of at least 10 cm for cooling purposes.



An excessively high environmental temperature has the following consequences:

- shorter lifecycle
- lower charging current
- lower peak power or full inverter shut-off.

Never place the device directly above the batteries.

The Quattro is suitable for wall mounting. For mounting purposes, a hook and two holes are provided at the back of the casing (see appendix G). The device can be fitted either horizontally or vertically. For optimal cooling, vertical fitting is preferred.



The inner part of the device should remain well accessible after installation.

The distance between the Quattro and the battery should be as short as possible to reduce voltage loss across the battery leads to a minimum.



Install the product in a heatproof environment. Ensure therefore that there are no chemicals, plastic parts, curtains or other textiles, etc. in the direct vicinity.



The Quattro has no internal DC fuse. The DC fuse should be installed outside the Quattro.

4.3 Requirements

- A crosshead (Phillips) screwdriver (PH 2) for removing the front panel.
- Spirit level for horizontal mounting of the support bracket for the unit.
- A flat-headed screwdriver No. 4 (1x4) for connecting the AC cables.
- A flat-headed screwdriver No. 1 (0.6x3.0) for connecting the options.
- An isolated box wrench (13 mm) for tightening the cable attachments to the negative and positive battery terminals.
- Four battery leads, including battery terminals and cable eyelets. (Considering the large power rating, two positive and two negative cables can be connected to the Quattro.)
- Three-core cable for the AC connections.

4.4 Connecting the battery leads

In order to use the full potential of the Quattro, batteries of sufficient capacity and battery leads with the correct cross-section should be used.

See table:

	12/5000/200	24/5000/120	48/5000/70
Recommended battery capacity (Ah)	800–2400	400–1400	200–800
Recommended DC fuse	750A	400A	200A
Recommended cross-section (mm ²) per + and - connection terminal			
0 – 5 m*	2x 90 mm ²	2x 50 mm ²	1x 70 mm ²
5 -10 m*		2x 90 mm ²	2x 70 mm ²

* '2x' means two positive and two negative cables.

Procedure

To connect the battery leads, follow the procedure below:



To prevent short circuiting of the battery, an isolated box wrench should be used.

- Remove the DC fuse.
- Loosen the four lower front panel screws at the front of the unit, and remove the lower front panel.
- Connect the battery leads: + (red) to the right-hand terminal and - (black) to the left-hand terminal (see appendix A).
- Tighten the connections after mounting the fastening parts.
- Tighten the nuts well for minimal contact resistance.
- Replace the DC fuse only after completing the whole installation procedure.

4.5 Connecting AC cables

The Quattro is a safety class I product (supplied with an ground terminal for safety purposes). **Its AC input and/or output terminals and/or grounding point on the outside of the product must be provided with an uninterruptable grounding point for safety purposes. See the following instructions in this regard.**



The Quattro is provided with a ground relay (see appendix) that **automatically connects the N output to the casing if no external AC supply is available**. If an external AC supply is provided, the ground relay will open before the input safety relay closes (relay H in appendix B). This ensures the correct operation of an earth leakage circuit breaker that is connected to the output.

- In a fixed installation, an uninterruptable grounding can be secured by means of the grounding wire of the AC input. Otherwise the casing must be grounded.
- In a mobile installation (for example, with a shore current plug), interrupting the shore connection will simultaneously disconnect the grounding connection. In that case, the casing must be connected to the chassis (of the vehicle) or to the hull or grounding plate (of the boat).
- In general, the connection described above to shore connection grounding is not recommended for boats because of galvanic corrosion. The solution to this is using an isolating transformer.

AC-in-1 (see appendix A)

If AC voltage is present on these terminals, the Quattro will use this connection. Generally a generator will be connected to AC-in-1. AC-in-1 is internally protected by a 30A thermal circuit breaker.

AC-in-2 (see appendix A)

If AC voltage is present on these terminals, the Quattro will use this connection, **unless voltage is also present on AC-in-1. The Quattro will then automatically select AC-in-1**. Generally the mains supply or shore voltage will be connected to AC-in-2. AC-in-2 is internally protected by a 30A thermal circuit breaker.

AC-out-1 (see appendix A)

The load is connected to these terminals. If AC voltage is available on AC-in-1 or AC-in-2, AC-out-1 will be connected through with AC-in-1 (priority input) or AC-in-2. If no AC voltage is available, AC-out-1 will be supplied by the inverter. An earth leakage circuit breaker and an automatic fuse for a maximum of 63A must be included in series with AC-out-1. (Maximum of 30A input current plus a maximum of 30A for additional inverter current). **The cable cross-section used must therefore also be suitable for currents up to 63A, unless the input current is limited to a lower value.**

AC-out-2 (see appendix A)

On these terminals, equipment is connected **that may only operate if AC voltage is available on AC-in-1 or AC-in-2**, e.g. an electric boiler.

AC-out-2 is internally protected with a 10A fuse (F3, see appendix A). An earth leakage circuit breaker must be included in series with AC-out-2, and possibly an automatic fuse for a maximum of 10A.

If several Quattro units are connected in parallel, as well as the AC-out-2 outputs, then the maximum current that can be delivered: $I_{out-max} = 10A + ((\text{number of units} - 1) \times 6A)$. Assuming three units connected in parallel, for example, then $I_{out-max} = 22A$.

Procedure

Use three-core cable. The connection terminals are clearly encoded:

PE: earth

N: neutral conductor

L: phase/live conductor

4.6 Connection options

4.6.1 Starter battery (connection terminal G, see appendix A)

The Quattro has a connection for charging a starter battery. Output current is limited to 4A.

4.6.2 Voltage sense (connection terminal E, see appendix A)

For compensating possible cable losses during charging, two sense wires can be connected with which the voltage direct on the battery or on the positive and negative distribution points can be measured. Use at least wire with a cross-section of 0,75mm². During battery charging, the Quattro will compensate the voltage drop over the DC cables to a maximum of 1 Volt (i.e. 1V over the positive connection and 1V over the negative connection). If the voltage drop threatens to become larger than 1V, the charging current is limited in such a way that the voltage drop remains limited to 1V.

4.6.3 Temperature sensor (connection terminal H, see appendix A)

For temperature-compensated charging, the temperature sensor (supplied with the Quattro) can be connected. The sensor is isolated and must be fitted to the negative terminal of the battery.

4.6.4 Remote control

The Quattro can be remotely controlled in two ways:

- With an external switch (connection terminal L, see appendix A). Operates only if the switch on the Quattro is set to "on".
- With a remote control panel (connected to one of the two RJ48 sockets B, see appendix A). Operates only if the switch on the Quattro is set to "on".

Using the remote control panel, only the current limit for AC-in-2 can be set (in regard to PowerControl and PowerAssist).

The current limit for AC-in-1 can be set with DIP switches or by means of software.

Only one remote control can be connected, i.e. either a switch or a remote control panel.

4.6.5 External relay

The maximum current that can be switched through from one of the AC inputs to the AC outputs is 30A.

If more than 30 amps is required to be switched through, a second Quattro can be connected in parallel or an external relay must be used. Please refer to your supplier for further details.

4.6.6 Connecting Quattro's in parallel (see appendix C)

The Quattro can be connected in parallel with several identical devices. To this end, a connection is established between the devices by means of standard RJ45 UTP cables. The **system** (one or more Quattro's plus optional control panel) will require subsequent configuration (see Section 5).

In the event of connecting Quattro units in parallel, the following requirements must be met:

- A maximum of six units connected in parallel.
- Only identical devices with the same power ratings may be connected in parallel.
- Battery capacity should be sufficient.
- The DC connection cables to the devices must be of equal length and cross-section.
- If a positive and a negative DC distribution point is used, the cross-section of the connection between the batteries and the DC distribution point must at least equal the sum of the required cross-sections of the connections between the distribution point and the Quattro units.
- Place the Quattro units close to each other, but allow at least 10 cm for ventilation purposes under, above and beside the units.
- UTP cables must be connected directly from one unit to the other (and to the remote panel). Connection/splitter boxes are not permitted.
- A battery-temperature sensor need only be connected to one unit in the system. If the temperature of several batteries is to be measured, you can also connect the sensors of other Quattro units in the system (with a maximum of one sensor per Quattro). Temperature compensation during battery charging responds to the sensor indicating the highest temperature.
- Voltage sensing must be connected to the master (see Section 5.5.1.4).
- If more than three units are connected in parallel in one system, a dongle is required (see Section 5).
- Only one remote control means (panel or switch) can be connected to the **system**.

4.6.7 Three-phase configuration (see appendix C)

Quattro's can also be used in 3-phase configuration. To this end, a connection between the devices is made by means of standard RJ45 UTP cables (the same as for parallel operation). The **system** (Quattro's plus an optional control panel) will require subsequent configuration (see Section 5).

Pre-requisites: see Section 4.6.6.

5. Configuration



- Settings may only be changed by a qualified electrical engineer.
- Read the instructions thoroughly before implementing changes.
- During setting of the charger, the DC fuse in the battery connections must be removed.

5.1 Standard settings: ready for use

On delivery, the Quattro is set to standard factory values. In general, these settings are selected for single-unit operation. Settings, therefore, do not require changing in the event of stand-alone use.

Warning: Possibly, the standard battery charging voltage is not suitable for your batteries! Refer to the manufacturer's documentation, or to your battery supplier!

Standard Quattro factory settings

Inverter frequency	50 Hz
Input frequency range	45 - 65 Hz
Input voltage range	180 - 265 VAC
Inverter voltage	230 VAC
Stand-alone / parallel / 3-phase	stand-alone
AES (Automatic Economy Switch)	off
Ground relay	on
Charger on/ off	on
Charging characteristics	four-stage adaptive with BatterySafe mode
Charging current	75% of the maximum charging current
Battery type	Victron Gel Deep Discharge (also suitable for Victron AGM Deep Discharge)
Automatic equalisation charging	off
Absorption voltage	14.4 / 28.8 / 57.6 V
Absorption time	up to 8 hours (depending on bulk time)
Float voltage	13.8 / 27.6 / 55.2 V
Storage voltage	13.2V (not adjustable)
Repeated absorption time	1 hour
Absorption repeat interval	7 days
Bulk protection	on
Generator (AC-in-1) / shore current (AC-in-2)	30A/16A (current limit for PowerControl and PowerAssist functions)
UPS feature	on
Dynamic current limiter	off
WeakAC	off
BoostFactor	2
Quattro-functional relay	alarm function
VirtualSwitch	controls the Quattro-functional relay
PowerAssist	on

5.2 Explanation of settings

Settings that are not self-explanatory are described briefly below. For further information, please refer to the help files in the software configuration programs (see Section 5.3).

Inverter frequency

Output frequency if no AC is present at the input.
Adjustability: 50Hz; 60Hz

Input frequency range

Input frequency range accepted by the Quattro. The Quattro synchronises within this range with the voltage present on AC-in-1 (priority input) or AC-in-2. Once synchronised, the output frequency will be equal to the input frequency.
Adjustability: 45 – 65 Hz; 45 – 55 Hz; 55 – 65 Hz

Input voltage range

Voltage range accepted by the Quattro. The Quattro synchronises within this range with the voltage present on AC-in-1 (priority input) or on AC-in-2. After the back feed relay has closed, output voltage will be equal to input voltage.
Adjustability: Lower limit: 180 - 230V
Upper limit: 230 - 270V

Inverter voltage

Output voltage of the Quattro in battery operation.
Adjustability: 210 – 245V

Stand-alone / parallel operation / 2-3 phase setting

Using several devices, it is possible to:

- increase total inverter power (several devices in parallel)
- create a split-phase system (only for Quattro units with 120V output voltage)
- create a 3-phase system.

To this end, the devices must be mutually connected with RJ45 UTP cables. Standard device settings, however, are such that each device operates in stand-alone operation. Reconfiguration of the devices is therefore required.

AES (Automatic Economy Switch)

If this setting is turned 'on', the power consumption in no-load operation and with low loads is decreased by approx. 20%, by slightly 'narrowing' the sinusoidal voltage. Not adjustable with DIP switches. Only applicable in stand-alone configuration.

Ground relay (see appendix B)

With this relay (H), the neutral conductor of the AC output is grounded to the casing when the back feed safety relays in the AC-in-1 and the AC-in-2 inputs are open. This ensures the correct operation of earth leakage circuit breakers in the outputs. If a non-grounded output is required during inverter operation, this function must be turned off. (See also Section 4.5)
Not adjustable with DIP switches.

Charging characteristics

The standard setting is 'Four-stage adaptive with BatterySafe mode'. See Section 2 for a description.
This is the best charging characteristic. See the help files in the software configuration programs for other features.
'Fixed' mode can be selected with DIP switches.

Battery type

The standard setting is the most suitable for Victron Gel Deep Discharge, Gel Exide A200, and tubular plate stationary batteries (OPzS). This setting can also be used for many other batteries: e.g. Victron AGM Deep Discharge and other AGM batteries, and many types of flat-plate open batteries. Four charging voltages can be set with DIP switches.

Absorption time

This depends on the bulk time (adaptive charging characteristic), so that the battery is optimally charged. If the 'fixed' charging characteristic is selected, the absorption time is fixed. For most batteries, a maximum absorption time of eight hours is suitable. If an extra high absorption voltage is selected for rapid charging (only possible for open, flooded batteries!), four hours is preferable. With DIP switches, a time of eight or four hours can be set. For the adaptive charging characteristic, this determines the maximum absorption time.

Storage voltage, Repeated Absorption Time, Absorption Repeat Interval

See Section 2. Not adjustable with DIP switches.

Bulk Protection

When this setting is 'on', the bulk charging time is limited to 10 hours. A longer charging time could indicate a system error (e.g. a battery cell short-circuit). Not adjustable with DIP switches.

Generator (AC-in-1) / Shore current (AC-in-2)

These are the standard current limit settings for which PowerControl and PowerAssist come into operation. See Section 2, the book 'Energy Unlimited', or the many descriptions of this unique feature on our website www.victronenergy.com.

UPS feature

If this setting is 'on' and AC on the input fails, the Quattro switches to inverter operation practically without interruption. The Quattro can then be used as an Uninterruptible Power Supply (UPS) for sensitive equipment such as computers or communication systems. The output voltage of some small generating sets is too unstable and distorted for using this setting – the Quattro would continually switch to inverter operation. For this reason, the setting can be turned off. The Quattro will then respond less quickly to voltage deviations on AC-in-1 or AC-in-2. The switchover time to inverter operation is consequently slightly longer, but most equipment (computers, clocks or household equipment) is not adversely impacted.

Recommendation: Turn the UPS feature off if the Quattro fails to synchronise, or continually switches back to inverter operation.

Dynamic current limiter

Intended for generators, the AC voltage being generated by means of a static inverter (so-called 'inverter' generators). In these generators, rotational speed is down-controlled if the load is low: this reduces noise, fuel consumption and pollution. A disadvantage is that the output voltage will drop severely or even completely fail in the event of a sudden load increase. More load can only be supplied after the engine is up to speed.

If this setting is 'on', the Quattro will start supplying extra power at a low generator output level and gradually allow the generator to supply more, until the set current limit is reached. This allows the generator engine to get up to speed.

This setting is also often used for 'classical' generators that respond slowly to sudden load variation.

WeakAC

Strong distortion of the input voltage can result in the charger hardly operating or not operating at all. If WeakAC is set, the charger will also accept a strongly distorted voltage, at the cost of greater distortion of the input current.

Recommendation: Turn WeakAC on if the charger is hardly charging or not charging at all (which is quite rare!). Also turn on the dynamic current limiter simultaneously, and reduce the maximum charging current to prevent overloading the generator if necessary. Not adjustable with DIP switches.

BoostFactor

Change this setting only after consulting with Victron Energy or with an engineer trained by Victron Energy!

Not adjustable with DIP switches.

Quattro-functional relay

By default, the Quattro-functional relay is set as an alarm relay, i.e. the relay will de-energise in the event of an alarm or a pre-alarm (inverter almost too hot, ripple on the input almost too high, battery voltage almost too low). Not adjustable with DIP switches.

VirtualSwitch

The VirtualSwitch is a software function in the Quattro microprocessor. The inputs of this function are parameters that can be selected with VEConfigure (e.g. certain alarms or voltage levels). The output is binary (0 or 1). The output can be connected to a binary microprocessor output (e.g. the Quattro-functional relay, or the relay in one of the AC inputs).

If connected to the Quattro-functional relay, and with battery voltage and time as input values, for example, the VirtualSwitch can be configured to supply a generator starting signal.

If connected to an AC input relay, and with battery voltage and time as input, for example, the connected mains supply can be interrupted.

Application: **A house or an office connected to the public mains, fitted with solar panels with energy storage in batteries.**

The batteries are used to prevent return delivery to the mains. During the day, redundant solar energy is stored in batteries. This energy is used in the evenings and at night. An energy shortfall is compensated by the mains. The Quattro converts the battery DC voltage to AC. The power is always less than or equal to the power consumption, so that return delivery to the mains does not occur. In the event of mains failure, the Quattro isolates the premises from the mains, which become autonomous (self-sufficient). In this way, a solar energy installation or a combined micro-scale heating and power plant can be economically used in areas with an unreliable mains supply and/or financially unfavourable energy-return conditions.

5.3 Configuration by computer

All settings can be changed by means of a computer or with a VE.Net panel (except for the Quattro-functional relay and the VirtualSwitch when using VE.Net).

The most common settings (including parallel and 3-phase operation) can be changed by means of DIP switches (see Section 5.4).

For changing settings with the computer, the following is required:

- VEConfigureII software. You can download the VEConfigureII software free of charge at www.victronenergy.com.
- A RJ45 UTP cable and the **MK2.2b** RS485-to-RS232 interface. If your computer has no RS232 connection, but does have USB, you will also need a **RS232-to-USB interface cable**. Both are available from Victron Energy.

5.3.1 VE.Bus Quick Configure Setup

VE.Bus Quick Configure Setup is a software program with which one Quattro unit or systems with a maximum of three Quattro units (parallel or three phase operation) can be configured in a simple manner. VEConfigureII forms part of this program.

You can download the software free of charge at www.victronenergy.com.

For connection to your computer, a RJ45 UTP cable and the **MK2.2b** RS485-to-RS232 interface is required.

If your computer does not have a RS232 connection but is equipped with USB, you will also need a **RS232-to-USB interface cable**. Both are available from Victron Energy.

5.3.2 VE.Bus System Configurator and dongle

For configuring advanced applications and/or systems with four or more Quattro units, **VE.Bus System Configurator** software must be used. You can download the software at www.victronenergy.com. VEConfigureII forms part of this program.

You can configure the system without a dongle, and use it for 15 minutes (as a demonstration facility). For permanent use, a dongle – available at additional charge – is required.

For connection to your computer, a RJ45 UTP cable and the **MK2.2b** RS485-to-RS232 interface is required.

If your computer does not have a RS232 connection but is equipped with USB, you will also need a **RS232-to-USB interface cable**. Both are available from Victron Energy.

5.4 Implementing settings with a VE.Net panel

To this end, a VE.Net panel and the VE.Net to VE.Bus converter is required.

With VE.Net you can set all parameters, with the exception of the Quattro-functional relay and the VirtualSwitch.

5.5 Configuration with DIP switches

Introduction

A number of settings can be changed using DIP switches (see appendix A, position M).

This is done as follows:

Turn the Quattro on, preferably unloaded and without AC voltage on the inputs. The Quattro will then operate in inverter mode.

Step 1: Setting the DIP switches for:

- The required current limitation of the AC inputs.
- Limitation of the charging current.
- Selection of stand-alone, parallel or 3-phase operation.

To store the settings after the required values have been set: press the 'Up' button for 2 seconds (**upper** button to the right of the DIP switches, see appendix A, position K). You can now re-use the DIP switches to apply the remaining settings (step 2).

Step 2: other settings

To store the settings after the required values have been set: press the 'Down' button for 2 seconds (**lower** button to the right of the DIP switches). You can now leave the DIP switches in the selected positions, so that the 'other settings' can always be recovered.

Remarks:

- The DIP switch functions are described in 'top to bottom' order. Since the uppermost DIP switch has the highest number (8), descriptions start with the switch numbered 8.
- In parallel mode or 3-phase mode, not all devices require all settings to be made (see section 5.5.1.4). For parallel or 3-phase mode, read the whole setting procedure and make a note of the required DIP switch settings before actually implementing them.

5.5.1 Step 1

5.5.1.2 Current limitation AC inputs (default: AC-in-1: 30A, AC-in-2: 16A)

If the current demand (Quattro load + battery charger) threatens to exceed the set current, the Quattro will first reduce its charging current (PowerControl), and subsequently supply additional power from the battery (PowerAssist), if needed.

The AC-in-1 current limit (the generator) can be set to eight different values by means of DIP switches.

The AC-in-2 current limit can be set to two different values by means of DIP switches. With a Phoenix Quattro Control Panel, a variable current limit can be set for the AC-in-2 input.

Remark: Using a Duo Control Panel is pointless if the internal transfer switch of the Quattro is used, because only the AC-in-2 input current can be set with the panel.

Procedure

AC-in-1 can be set using DIP switches ds8, ds7 and ds6 (default setting: 30A).

Procedure: set the DIP switches to the required value:

ds8	ds7	ds6	
off	off	off	= 6A (1.4kVA at 230V)
off	off	on	= 10A (2.3kVA at 230V)
off	on	off	= 12A (2.8kVA at 230V)
off	on	on	= 16A (3.7kVA at 230V)
on	off	off	= 20A (4.6kVA at 230V)
on	off	on	= 23A (5.3kVA at 230V)
on	on	off	= 26A (6.0kVA at 230V)
on	on	on	= 30A (6.9kVA at 230V)

Remark: **Manufacturer-specified continuous power ratings for small generators are sometimes inclined to be rather optimistic. In that case, the current limit should be set to a much lower value than would otherwise be required on the basis of manufacturer-specified data.**

AC-in-2 can be set in two steps using DIP switch ds5 (default setting: 16A).

Procedure: set ds5 to the required value:

ds5	
off	= 16A
on	= 30A

5.5.1.3 Charging current limitation (default setting 75%)

For maximum battery life, a charging current of 10% to 20% of the capacity in Ah should be applied.

Example: optimal charging current of a 24V/500Ah battery bank: 50A to 100A.

The temperature sensor supplied automatically adjusts the charging voltage to the battery temperature.

If faster charging – and a subsequent higher current – is required:

- the temperature sensor supplied should be fitted to the battery, since fast charging can lead to a considerable temperature rise of the battery bank. The charging voltage is adapted to the higher temperature (i.e. lowered) by means of the temperature sensor.
- the bulk charging time will sometimes be so short that a fixed absorption time would be more satisfactory ('fixed' absorption time, see ds5, step 2).

Procedure

The battery charging current can be set in four steps, using DIP switches ds4 and ds3 (default setting: 75%).

ds4 ds3

off off = 25%

off on = 50%

on off = 75%

on on = 100%

5.5.1.4 Stand-alone, parallel and 3-phase operation

Using DIP switches ds2 and ds1, three system configurations can be selected.

NOTE:

- When configuring a parallel or 3-phase system, all related devices should be interconnected using RJ45 UTP cables (see appendix C, D). All devices must be turned on. They will subsequently return an error code (see Section 7), since they have been integrated into a system and still are configured as 'stand-alone'. This error message can safely be ignored.
- Storing settings (by pressing the 'Up' button (step 1) – and later on the 'Down' button (step 2) – for 2 seconds) should be done on one device only. This device is the 'master' in a parallel system or the 'leader' (L1) in a 3-phase system. In a parallel system, the step-1 setting of DIP switches ds8 to ds3 need to be done on the master only. The slaves will follow the master with regard to these settings (hence the master/slave relationship). In a 3-phase system, a number of settings are required for the other devices, i.e. the followers (for phases L2 and L3). (The followers, therefore, do not follow the leader for all settings, hence the leader/follower terminology).
- A change in the setting 'stand-alone / parallel / 3-phase' is only activated after the setting has been stored (by pressing the 'UP' button for 2 seconds) **and** after all devices have been turned off and then on again. In order to start up a VE.Bus system correctly, all devices should therefore be turned off after the settings have been stored. They can then be turned on in any order. The system will not start until all devices have been turned on.
- Note that only identical devices can be integrated in one system. Any attempt to use different models in one system will fail. Such devices may possibly function correctly again only after individual reconfiguration for 'stand-alone' operation.
- The combination **ds2=on** and **ds1=on** is not used.

DIP switches ds2 and ds1 are reserved for the selection of stand-alone, parallel or 3-phase operation

Stand-alone operation

Step 1: Setting ds2 and ds1 for stand-alone operation

- DS-8 AC-in-1 Set as desired
- DS-7 AC-in-1 Set as desired
- DS-6 AC-in-1 Set as desired
- DS-5 AC-in-2 Set as desired
- DS-4 Charging current Set as desired
- DS-3 Charging current Set as desired
- DS-2 Stand-alone operation
- DS-1 Stand-alone operation

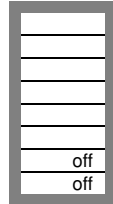

Examples of DIP switch settings for stand-alone mode are given below.

Example 1 shows the factory setting (since factory settings are entered by computer, all DIP switches of a new product are set to 'off').

Important: When a panel is connected, the AC-in-2 current limit is determined by the panel and not by the value stored in the Quattro.

Four examples of stand-alone settings:

DS-8 AC-in-1 <input type="checkbox"/> on DS-7 AC-in-1 <input type="checkbox"/> on DS-6 AC-in-1 <input type="checkbox"/> on DS-5 AC-in-2 <input type="checkbox"/> off DS-4 Charging current <input type="checkbox"/> on DS-3 Charging current <input type="checkbox"/> off DS-2 Stand-alone mode <input type="checkbox"/> off DS-1 Stand-alone mode <input type="checkbox"/> off	DS-8 <input type="checkbox"/> on DS-7 <input type="checkbox"/> on DS-6 <input type="checkbox"/> on DS-5 <input type="checkbox"/> off DS-4 <input type="checkbox"/> on DS-3 <input type="checkbox"/> on DS-2 <input type="checkbox"/> off DS-1 <input type="checkbox"/> off	DS-8 <input type="checkbox"/> off DS-7 <input type="checkbox"/> on DS-6 <input type="checkbox"/> on DS-5 <input type="checkbox"/> off DS-4 <input type="checkbox"/> on DS-3 <input type="checkbox"/> on DS-2 <input type="checkbox"/> off DS-1 <input type="checkbox"/> off	DS-8 <input type="checkbox"/> on DS-7 <input type="checkbox"/> on DS-6 <input type="checkbox"/> off DS-5 <input type="checkbox"/> on DS-4 <input type="checkbox"/> off DS-3 <input type="checkbox"/> on DS-2 <input type="checkbox"/> off DS-1 <input type="checkbox"/> off
Step1, stand-alone Example 1 (factory setting): 8, 7, 6 AC-in-1: 30A 5 AC-in-2: 16A 4, 3 Charging current: 75% 2, 1 Stand-alone mode	Step1, stand-alone Example 2: 8, 7, 6 AC-in-1: 30A 5 AC-in-2: 16A 4, 3 Charge: 100% 2, 1 Stand-alone	Step1, stand-alone Example 3: 8, 7, 6 AC-in-1: 16A 5 AC-in-2: 16A 4, 3 Charge: 100% 2, 1 Stand-alone	Step1, stand-alone Example 4: 8, 7, 6 AC-in-1: 26A 5 AC-in-2: 30A 4, 3 Charge: 50% 2, 1 Stand-alone

To store the settings after the required values have been set: press the 'Up' button for 2 seconds (**upper** button to the right of the DIP switches, see appendix A, position K). **The overload and low-battery LEDs will flash to indicate acceptance of the settings.**

We recommend making a note of the settings, and filing this information in a safe place.

You can now re-use the DIP switches to apply the remaining settings (step 2).

Parallel operation (see appendix C)

Step 1: Setting ds2 and ds1 for parallel operation

Master		Slave 1	Slave 2 (optional)
DS-8 AC-in-1	Set	DS-8 na	DS-8 na
DS-7 AC-in-1	Set	DS-7 na	DS-7 na
DS-6 AC-in-1	Set	DS-6 na	DS-6 na
DS-5 AC-in-2	Set	DS-5 na	DS-5 na
DS-4 Ch. current	Set	DS-4 na	DS-4 na
DS-3 Ch. current	Set	DS-3 na	DS-3 na
DS-2 Master	off	DS-2 Slave 1	DS-2 Slave 2
DS-1 Master	on	DS-1 Slave 1	DS-1 Slave 2

The current settings (AC current limitation and charging current) are multiplied by the number of devices. However, the AC current limitation setting when using a remote panel will always correspond to the value indicated on the panel and should **not** be multiplied by the number of devices.

Example: 15kVA parallel system

- If an AC-in-1 current limitation of 20A is set on the master and the system consists of three devices, then the effective system current limitation for AC-in-1 is equal to $3 \times 20 = 60A$ (setting for generator power $60 \times 230 = 13.8kVA$).
- If a 30A panel is connected to the master, the system current limitation for AC-in-2 is adjustable to a maximum of 30A, regardless of the number of devices.
- If the charging current on the master is set to 100% (120A for a Quattro 24/5000/120) and the system consists of three devices, then the effective system charging current is equal to $3 \times 120 = 360A$.

The settings according to this example (15kVA parallel system) are as follows:

Master	Slave 1	Slave 2
DS-8 AC-in-1 (3 x 20 = 60A)	DS-8 na	DS-8 na
DS-7 AC-in-1 (3 x 20 = 60A)	DS-7 na	DS-7 na
DS-6 AC-in-1 (3 x 20 = 60A)	DS-6 na	DS-6 na
DS-5 AC-in-2 na (30A panel)	DS-5 na	DS-5 na
DS-4 Charging current 3x120A	DS-4 na	DS-4 na
DS-3 Charging current 3x120A	DS-3 na	DS-3 na
DS-2 Master	DS-2 Slave 1	DS-2 Slave 2
DS-1 Master	DS-1 Slave 1	DS-1 Slave 2

To store the settings after the required values have been set: press the 'Up' button of the **master** for 2 seconds (**upper** button to the right of the DIP switches, see appendix A, position K). **The overload and low-battery LEDs will flash to indicate acceptance of the settings.**

We recommend making a note of the settings, and filing this information in a safe place.

You can now re-use the DIP switches to apply the remaining settings (step 2).

Three phase operation (see appendix D)
Step 1: Setting ds2 and ds1 for 3-phase operation

Leader (L1)		Follower (L2)		Follower (L3)	
DS-8 AC-in-1	Set	DS-8 Set		DS-8 Set	
DS-7 AC-in-1	Set	DS-7 Set		DS-7 Set	
DS-6 AC-in-1	Set	DS-6 Set		DS-6 Set	
DS-5 AC-in-2	Set	DS-5 Set		DS-5 Set	
DS-4 Ch. current	Set	DS-4 na		DS-4 na	
DS-3 Ch. current	Set	DS-3 na		DS-3 na	
DS-2 Leader	on	DS-2 Slave 1	off	DS-2 Slave 2	off
DS-1 Leader	off	DS-1 Slave 1	off	DS-1 Slave 2	on

As the table above shows, the current limits for each phase should be set separately (ds8 thru ds5). Thus, for AC-in1 as well as AC-in-2, different current limits per phase can be selected. If a panel is connected, the AC-in-2 current limit will equal the value set on the panel for all phases. The maximum charging current is the same for all devices, and should be set on the leader (ds4 and ds3).

Example:

- AC-in-1 current limitation on the leader and the followers: 16A (setting for generator power $16 \times 230 \times 3 = 11\text{kVA}$).
- AC-in-2 current limitation with 16A panel.
- If the charging current on the leader is set to 100% (120A for a Quattro 24/5000/120) and the system consists of three devices, then the effective system charging current is equal to $3 \times 120 = 360\text{A}$.

The settings according to this example (15kVA 3-phase system) are as follows:

Leader (L1)		Follower (L2)		Follower (L3)	
DS-8 AC-in-1	16A	DS-8 AC-in-1	16A	DS-8 AC-in-1	16A
DS-7 AC-in-1	16A	DS-7 AC-in-1	16A	DS-7 AC-in-1	16A
DS-6 AC-in-1	16A	DS-6 AC-in-1	16A	DS-6 AC-in-1	16A
DS-5 AC-in-2 na (16A panel)		DS-5 na		DS-5 na	
DS-4 Ch. current	3x120A	DS-4 na		DS-4 na	
DS-3 Ch. current	3x120A	DS-3 na		DS-3 na	
DS-2 Leader	on	DS-2 Slave 1	off	DS-2 Slave 2	off
DS-1 Leader	off	DS-1 Slave 1	off	DS-1 Slave 2	on

To store the settings after the required values have been set: press the 'Up' button of the **leader** for 2 seconds (**upper** button to the right of the DIP switches, see appendix A, position K). **The overload and low-battery LEDs will flash to indicate acceptance of the settings.**

We recommend making a note of the settings, and filing this information in a safe place.

You can now re-use the DIP switches to apply the remaining settings (step 2).

5.5.2 Step 2: Other settings

The remaining settings are not relevant for slaves.

Some of the remaining settings are not relevant for followers (**L2, L3**). These settings are imposed on the whole system by the leader **L1**. If a setting is irrelevant for **L2, L3** devices, this is mentioned explicitly.

ds8-ds7: Setting charging voltages (**not relevant for L2, L3**)

ds8-ds7	Absorption voltage	Float voltage	Storage voltage	Suitable for
off off	14.1 28.2 56.4	13.8 27.6 55.2	13.2 26.4 52.8	Gel Victron Long Life (OPzV) Gel Exide A600 (OPzV) Gel MK battery
off on	14.4 28.8 57.6	13.8 27.6 55.2	13.2 26.4 52.8	Gel Victron Deep Discharge Gel Exide A200 AGM Victron Deep Discharge Stationary tubular plate (OPzS)
on off	14.7 29.4 58.8	13.8 27.6 55.2	13.2 26.4 52.8	AGM Victron Deep Discharge Tubular plate (OPzS) batteries in semi-float mode AGM spiral cell
on on	15.0 30.0 60.0	13.8 27.6 55.2	13.2 26.4 52.8	Tubular plate (OPzS) batteries in cyclic mode

ds6: absorption time 8 or 4 hours (**not relevant for L2, L3**) on = 8 hours off = 4 hours

ds5: adaptive charging characteristic (**not relevant for L2, L3**) on = active off = inactive (fixed absorption time)

ds4: dynamic current limiter on = active off = inactive

ds3: UPS function on = active off = inactive

ds2: converter voltage on = 230V / 120V off = 240V / 115V

ds1: converter frequency (**not relevant for L2, L3**) on = 50Hz off = 60Hz
(the wide input frequency range (45-55Hz) is 'on' by default)

Step 2: Exemplary settings for stand-alone mode

Example 1 is the factory setting (since factory settings are entered by computer, all DIP switches of a new product are set to 'off').

DS-8 Ch. voltage <input type="checkbox"/> off DS-7 Ch. voltage <input type="checkbox"/> on DS-6 Absorpt. time <input type="checkbox"/> on DS-5 Adaptive ch. <input type="checkbox"/> on DS-4 Dyn. Curr. limit <input type="checkbox"/> off DS-3 UPS function: <input type="checkbox"/> on DS-2 Voltage <input type="checkbox"/> on DS-1 Frequency <input type="checkbox"/> on	DS-8 <input type="checkbox"/> off DS-7 <input type="checkbox"/> off DS-6 <input type="checkbox"/> on DS-5 <input type="checkbox"/> on DS-4 <input type="checkbox"/> off DS-3 <input type="checkbox"/> off DS-2 <input type="checkbox"/> on DS-1 <input type="checkbox"/> on	DS-8 <input type="checkbox"/> on DS-7 <input type="checkbox"/> off DS-6 <input type="checkbox"/> on DS-5 <input type="checkbox"/> on DS-4 <input type="checkbox"/> on DS-3 <input type="checkbox"/> off DS-2 <input type="checkbox"/> off DS-1 <input type="checkbox"/> on	DS-8 <input type="checkbox"/> on DS-7 <input type="checkbox"/> on DS-6 <input type="checkbox"/> off DS-5 <input type="checkbox"/> off DS-4 <input type="checkbox"/> off DS-3 <input type="checkbox"/> on DS-2 <input type="checkbox"/> off DS-1 <input type="checkbox"/> off
Step 2 Example 1 (factory setting): 8, 7 GEL 14,4V 6 Absorption time: 8 hours 5 Adaptive charging: on 4 Dynamic current limit: off 3 UPS function: on 2 Voltage: 230V 1 Frequency: 50Hz	Step 2 Example 2: 8, 7 OPzV 14,1V 6 Absorption time: 8 h 5 Adaptive charging: on 4 Dyn. current limit: off 3 UPS function: off 2 Voltage: 230V 1 Frequency: 50Hz	Step 2 Example 3: 8, 7 AGM 14,7V 6 Absorption time: 8 h 5 Adaptive charging: on 4 Dyn. current limit: on 3 UPS function: off 2 Voltage: 240V 1 Frequency: 50Hz	Step 2 Example 4: 8, 7 Tubular-plate 15V 6 Absorption time: 4 h 5 Fixed absorption time 4 Dyn. current limit: off 3 UPS function: on 2 Voltage: 240V 1 Frequency: 60Hz

To store the settings after the required values have been set: press the 'Down' button for 2 seconds (**lower** button to the right of the DIP switches). **The temperature and low-battery LEDs will flash to indicate acceptance of the settings.**

You can then leave the DIP switches in the selected positions, so that the 'other settings' can always be recovered.

Step 2: Exemplary setting for parallel mode

In this example, the master is configured according to factory settings.
The slaves do not require setting!

Master	Slave 1	Slave 2
DS-8 Ch. voltage(GEL 14,4V) <input type="checkbox"/> off	DS-8 na <input type="checkbox"/>	DS-8 na <input type="checkbox"/>
DS-7 Ch. voltage(GEL 14,4V) <input type="checkbox"/> on	DS-7 na <input type="checkbox"/>	DS-7 na <input type="checkbox"/>
DS-6 Absorption time (8 h) <input type="checkbox"/> on	DS-6 na <input type="checkbox"/>	DS-6 na <input type="checkbox"/>
DS-5 Adaptive charging (on) <input type="checkbox"/> on	DS-5 na <input type="checkbox"/>	DS-5 na <input type="checkbox"/>
DS-4 Dyn. current limit (off) <input type="checkbox"/> off	DS-4 na <input type="checkbox"/>	DS-4 na <input type="checkbox"/>
DS-3 UPS function (on) <input type="checkbox"/> on	DS-3 na <input type="checkbox"/>	DS-3 na <input type="checkbox"/>
DS-2 Voltage (230V) <input type="checkbox"/> on	DS-2 na <input type="checkbox"/>	DS-2 na <input type="checkbox"/>
DS-1 Frequency (50Hz) <input type="checkbox"/> on	DS-1 na <input type="checkbox"/>	DS-1 na <input type="checkbox"/>

To store the settings after the required values have been set: press the 'Down' button of the **master** for 2 seconds (**lower** button to the right of the DIP switches). **The temperature and low-battery LEDs will flash to indicate acceptance of the settings.**

You can then leave the DIP switches in the selected positions, so that the 'other settings' can always be recovered.

To start the system: first, turn all devices off. The system will start up as soon as all devices have been turned on.

Step 2: Exemplary setting for 3-phase mode

In this example the leader is configured according to factory settings.

Leader (L1)	Follower (L2)	Follower (L3)
DS-8 Ch. Volt. GEL 14,4V <input type="checkbox"/> off	DS-8 na <input type="checkbox"/>	DS-8 na <input type="checkbox"/>
DS-7 Ch. Volt. GEL 14,4V <input type="checkbox"/> on	DS-7 na <input type="checkbox"/>	DS-7 na <input type="checkbox"/>
DS-6 Absorption time (8 h) <input type="checkbox"/> on	DS-6 na <input type="checkbox"/>	DS-6 na <input type="checkbox"/>
DS-5 Adaptive ch. (on) <input type="checkbox"/> on	DS-5 na <input type="checkbox"/>	DS-5 na <input type="checkbox"/>
DS-4 Dyn. current limit (off) <input type="checkbox"/> off	DS-4 D. c. l. (off) <input type="checkbox"/> off	DS-4 D. c. l. (off) <input type="checkbox"/> off
DS-3 UPS function (on) <input type="checkbox"/> on	DS-3 UPS f. (on) <input type="checkbox"/> on	DS-3 UPS f. (on) <input type="checkbox"/> on
DS-2 Voltage (230V) <input type="checkbox"/> on	DS-2 V (230V) <input type="checkbox"/> on	DS-2 V (230V) <input type="checkbox"/> on
DS-1 Frequency (50Hz) <input type="checkbox"/> on	DS-1 na <input type="checkbox"/>	DS-1 na <input type="checkbox"/>

To store the settings after the required values have been set: press the 'Down' button of the **leader** for 2 seconds (**lower** button to the right of the DIP switches). **The temperature and low-battery LEDs will flash to indicate acceptance of the settings.**

You can then leave the DIP switches in the selected positions, so that the 'other settings' can always be recovered.

To start the system: first, turn all devices off. The system will start up as soon as all devices have been turned on.

6 Maintenance

The Quattro does not require specific maintenance. It will suffice to check all connections once a year. Avoid moisture and oil/soot/vapours, and keep the device clean.

7 Error indications

With the procedures below, most errors can be quickly identified. If an error cannot be resolved, please refer to your Victron Energy supplier.

7.1 General error indications

Problem	Cause	Solution
No output voltage on AC-out-2.	Quattro in inverter mode Defective fuse F3 (see appendix A).	Remove overload or short circuit on AC-out-2 and replace fuse F3 (16A).
Quattro will not switch over to generator or mains operation.	Thermal circuit breaker (TCB) in the AC-in-1 or AC-in-2 input is open as a result of overload.	Remove overload or short circuit on AC-out-1 or AC-out-2, and press TCB for recovery (see appendix A, position N and O)
Inverter operation not initiated when switched on.	The battery voltage is excessively high or too low. No voltage on DC connection.	Ensure that the battery voltage is within the correct range.
"Low battery" LED flashes.	The battery voltage is low.	Charge the battery or check the battery connections.
"Low battery" LED lights.	The converter switches off because the battery voltage is too low.	Charge the battery or check the battery connections.
"Overload" LED flashes.	The converter load is higher than the nominal load.	Reduce the load.
"Overload" LED lights.	The converter is switched off due to excessively high load.	Reduce the load.
"Temperature" LED flashes or lights.	The environmental temperature is high, or the load is too high.	Install the converter in cool and well-ventilated environment, or reduce the load.
"Low battery" and "overload" LEDs flash intermittently.	Low battery voltage and excessively high load.	Charge the batteries, disconnect or reduce the load, or install higher capacity batteries. Fit shorter and/or thicker battery cables.
"Low battery" and "overload" LEDs flash simultaneously.	Ripple voltage on the DC connection exceeds 1,5Vrms.	Check the battery cables and battery connections. Check whether battery capacity is sufficiently high, and increase this if necessary.
"Low battery" and "overload" LEDs light.	The inverter is switched off due to an excessively high ripple voltage on the input.	Install batteries with a larger capacity. Fit shorter and/or thicker battery cables, and reset the inverter (switch off, and then on again).
One alarm LED lights and the second flashes.	The inverter is switched off due to alarm activation by the lighted LED. The flashing LED indicates that the inverter was about to switch off due to the related alarm.	Check this table for appropriate measures in regard to this alarm state.
The charger does not operate.	The AC input voltage or frequency is not within the range set.	Ensure that the AC input is between 185 VAC and 265 VAC, and that the frequency is within the range set (default setting 45-65Hz).
	Thermal circuit breaker (TCB) in the AC-in-1 or AC-in-2 input is open.	Press TCB for recovery (see appendix A, position N and O).
	The battery fuse has blown.	Replace the battery fuse.
	The distortion or the AC input voltage is too large (generally generator supply).	Turn the settings WeakAC and dynamic current limiter on.
The battery is not completely charged.	Charging current excessively high, causing premature absorption phase.	Set the charging current to a level between 0.1 and 0.2 times the battery capacity.
	Poor battery connection.	Check the battery connections.
	The absorption voltage has been set to an incorrect level (too low).	Set the absorption voltage to the correct level.
	The float voltage has been set to an incorrect level (too low).	Set the float voltage to the correct level.
	The available charging time is too short to fully charge the battery.	Select a longer charging time or higher charging current.
The battery is overcharged.	The absorption time is too short. For adaptive charging this can be caused by an extremely high charging current with respect to battery capacity, so that bulk time is insufficient.	Reduce the charging current or select the 'fixed' charging characteristics.
	The absorption voltage is set to an incorrect level (too high).	Set the absorption voltage to the correct level.
	The float voltage is set to an incorrect level (too high).	Set the float voltage to the correct level.
	Poor battery condition.	Replace the battery.
The charging current drops to 0 as soon as the absorption phase initiates.	The battery temperature is too high (due to poor ventilation, excessively high environmental temperature, or excessively high charging current).	Improve ventilation, install batteries in a cooler environment, reduce the charging current, and connect the temperature sensor.
	The battery is over-heated (>50 °C)	<ul style="list-style-type: none"> — Install the battery in a cooler environment — Reduce the charging current — Check whether one of the battery cells has an internal short circuit
	Defective battery temperature sensor	Disconnect the temperature sensor plug in the Quattro. If charging functions correctly after approximately 1 minute, the temperature sensor should be replaced.

7.2 Special LED indications

(for the normal LED indications, see section 3.4)

Bulk and absorption LEDs flash synchronously (simultaneously).	Voltage sense error. The voltage measured at the voltage sense connection deviates too much (more than 7V) from the voltage on the positive and negative connection of the device. There is probably a connection error. The device will remain in normal operation. NOTE: If the "inverter on" LED flashes in phase opposition, this is a VE.Bus error code (see further on).
Absorption and float LEDs flash synchronously (simultaneously).	The battery temperature as measured has an extremely unlikely value. The sensor is probably defective or has been incorrectly connected. The device will remain in normal operation. NOTE: If the "inverter on" LED flashes in phase opposition, this is a VE.Bus error code (see further on).
"Mains on" flashes and there is no output voltage.	The device is in "charger only" operation and mains supply is present. The device rejects the mains supply or is still synchronising.

7.3 VE.Bus LED indications

Equipment included in a VE.Bus system (a parallel or 3-phase arrangement) can provide so-called VE.Bus LED indications. These LED indications can be subdivided into two groups: OK codes and error codes.

7.3.1 VE.Bus OK codes

If the internal status of a device is in order but the device cannot yet be started because one or more other devices in the system indicate an error status, the devices that are in order will indicate an OK code. This facilitates error tracing in a VE.Bus system, since devices not requiring attention are easily identified as such.

Important: OK codes will only be displayed if a device is not in inverter or charging operation!

For a Quattro/Quattro:

- A flashing "bulk" LED indicates that the device can perform inverter operation.
- A flashing "float" LED indicates that the device can perform charging operation.

For an inverter:

- The "inverter on" LED must flash.
- A flashing "overload" LED indicates that the device can perform inverter operation.
- A flashing "temperature" LED indicates that the device is not blocking charging operation.

NOTE: In principle, all other LEDs must be off. If this is not the case, the code is not an OK code. However, the following exceptions apply:

- The special LED indications above can occur together with the OK codes.
- The "low battery" LED can function together with the OK code that indicates that the device can charge.

7.3.2 VE.Bus error codes

A VE.Bus system can display various error codes. These codes are displayed with the "inverter on", "bulk", "absorption" and "float" LEDs.

To interpret a VE.Bus error code correctly, the following procedure should be followed:

1. Is the "inverter on" LED flashing? If not, then there is **no** VE.Bus error code.
2. If one or more of the LEDs "bulk", "absorption" or "float" flashes, then this flash must be in phase opposition to the "inverter on" LED, i.e. the flashing LEDs are off if the "inverter on" LED is on, and vice versa. If this is not the case, then there is **no** VE.Bus error code.
3. Check the "bulk" LED, and determine which of the three tables below should be used.
4. Select the correct column and row (depending on the "absorption" and "float" LEDs), and determine the error code.
5. Determine the meaning of the code in the table below.

		Bulk LED off			Bulk LED flashes			Bulk LED on		
		Absorption LED			Absorption LED			Absorption LED		
Float LED	off	off	flashing	on	off	flashing	on	off	flashing	on
	flashing	0	3	6	9	12	15	18	21	24
	on	1	4	7	10	13	16	19	22	25
on	2	5	8	11	14	17	20	23	26	

Code	Meaning:	Cause/solution:
1	Device is switched off because one of the other phases in the system has switched off.	Check the failing phase.
3	Not all, or more than, the expected devices were found in the system.	The system is not properly configured. Reconfigure the system.
4	No other device whatsoever detected.	Check the communication cables.
5	Overvoltage on AC-out.	Check the AC cables.
10	System time synchronisation problem occurred.	Should not occur in correctly installed equipment. Check the communication cables.
14	Device cannot transmit data.	Check the communication cables (there may be a short circuit).
16	System is switched off because it is a so-called extended system and a 'dongle' is not connected.	Connect dongle.
17	One of the devices has assumed 'master' status because the original master failed.	Check the failing unit. Check the communication cables.
18	Overvoltage has occurred.	Check AC cables.
22	This device cannot function as 'slave'.	This device is an obsolete and unsuitable model. It should be replaced.
24	Switch-over system protection initiated.	Should not occur in correctly installed equipment. Switch all equipment off, and then on again. If the problem recurs, check the installation.
25	Firmware incompatibility. The firmware of one of the connected devices is not sufficiently up to date to operate in conjunction with this device.	1) Switch all equipment off. 2) Switch the device returning this error message on. 3) Switch on all other devices one by one until the error message reoccurs. 4) Update the firmware in the last device that was switched on.
26	Internal error.	Should not occur. Switch all equipment off, and then on again. Contact Victron Energy if the problem persists.

8. Technical specifications

Quattro	12/5000/200	24/5000/120	48/5000/70
PowerControl / PowerAssist	Yes	Yes	Yes
Integrated Transfer switch	Yes	Yes	Yes
AC inputs (2x)	Input voltage range: 187-265 VAC Input frequency: 45 – 55 Hz Power factor: 1		
Maximum feed through current (A)	30	30	30
INVERTER			
Input voltage range (V DC)	9,5 – 17	19 – 33	38 – 66
Output (1)	Output voltage: 230 VAC ± 2%		Frequency: 50 Hz ± 0,1%
Cont. output power at 25 °C (VA) (3)	5000	5000	5000
Cont. output power at 25 °C (W)	4000	4250	4250
Cont. output power at 40 °C (W)	3000	3350	3350
Peak power (W)	7000	7500	7800
Maximum efficiency (%)	92	94	95
Zero-load power (W)	25	30	30
Load shedding output	Max load: 10A Switches off when no external AC source available		
CHARGER			
Charge voltage 'absorption' (V DC)	14,4	28,8	57,6
Charge voltage 'float' (V DC)	13,8	27,6	55,2
Storage mode (V DC)	13,2	26,4	52,8
Charge current house battery (A) (4)	200	120	70
Charge current starter battery (A)	4		
Battery temperature sensor	ja		
GENERAL			
Multi purpose relay (5)	Yes	Yes	Yes
Protection (2)	a - g		
Common Characteristics	Operating temp.: -20 to +50 °C (fan assisted cooling) Humidity (non condensing) : max 95%		
ENCLOSURE			
Common Characteristics	Material & Colour: aluminium (blue RAL 5012)		Protection: IP 21
Battery-connection	Four M8 bolts (2 plus and 2 minus connctions)		
230 V AC-connection	Screw clamp 13mm ² (AWG 6)		
Weight (kg)	30		
Dimensions (hwxwd in mm)	444 x 328 x 240		
STANDARDS			
Safety	EN 60335-1, EN 60335-2-29		
Emission / Immunity	EN55014-1, EN 61000-3-2 / EN 55014-2, EN 61000-3-3		

1) Can be adjusted to 60 Hz; 120 V 60 Hz on request

2) Protection

- a. Output short circuit
- b. Overload
- c. Battery voltage too high
- d. Battery voltage too low
- e. 230VAC on inverter output
- f. Input voltage ripple too high
- g. Temperature too high

3) Non linear load, crest factor 3:1

4) At 25 °C ambient

5) Multipurpose relay which can be set for general alarm, DC undervoltage or genset start signal function

APPENDIX A: Connection overview

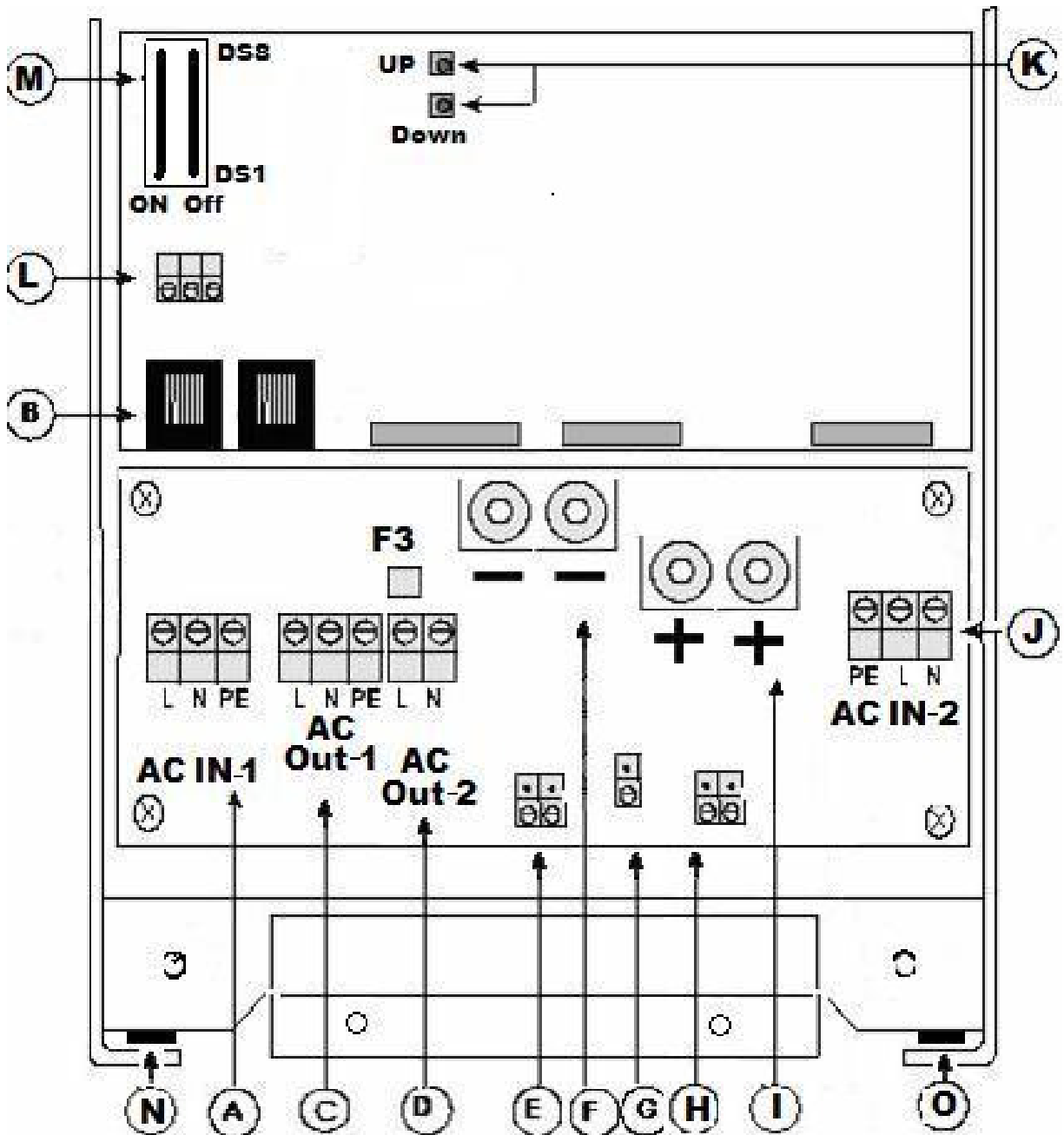

APPENDIX A: Connection overview

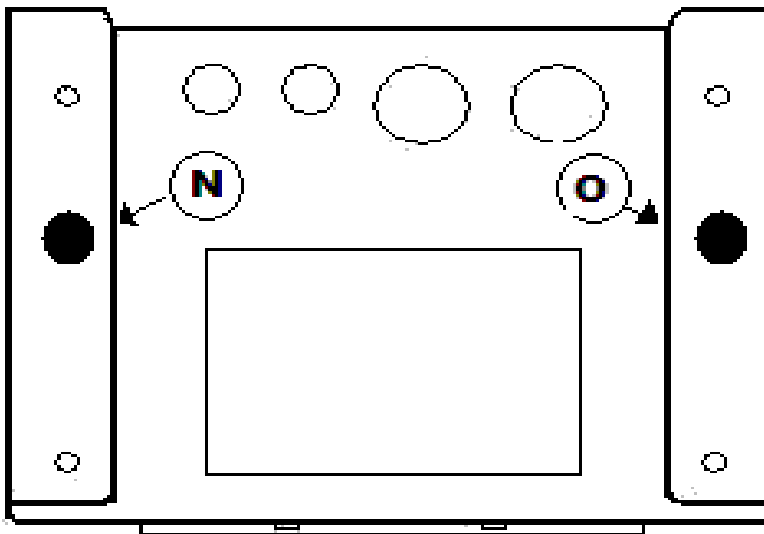

English:

A	AC input (generator input) AC-in-1. Left to right: L (phase), N (neutral), PE (ground).
B	2x RJ45 connector for remote panel and/or parallel and 3-phase operation.
C	AC output AC-out-1. Left to right: L (phase), N (neutral), PE (ground).
D	AC output AC-out-2. Left to right: L (phase), N (neutral), Maximum current 16A. Protected by fuse F3.
E	Terminals for (left to right): Voltage sense positive +, Voltage sense minus -
F	Double M8 battery minus connection.
G	Starter battery positive. (<i>starter battery minus: use battery minus cable for connection</i>).
H	Terminals for (left to right): temperature sensor positive, temperature sensor minus.
I	Double M8 battery positive connection.
J	AC input (shore/grid supply) AC-in-2. Left to right: L (phase), N (neutral), PE (ground).
K	Pushbuttons for set-up mode
L	Connector for remote switch: Short left and middle terminal to switch "on". Short right and middle terminal to switch to "charger only".
M	DIP switches for set-up mode.
N	30A thermal circuit breaker in series with AC-in-1 (bottom cabinet left).
O	30A thermal circuit breaker in series with AC-in-2 (bottom cabinet right).

Dutch:

A	Wisselspanning ingang (generator) AC-in-1. Van links naar rechts: L (fase), N (nul), PE (aarde).
B	2x RJ45 connector voor afstandbedieningspaneel en/of parallel and 3-fase bedrijf.
C	Wisselspanning uitgang AC-out-1. Van links naar rechts: L (fase), N (nul), PE (aarde).
D	Wisselspanning uitgang AC-out-2. Van links naar rechts: L (fase), N (nul). Max. stroom 16A. Beveiligd met zekering F3.
E	Aansluitklemmen voor (van links naar rechts): voltage sense plus +, voltage sense minus.
F	Dubbele M8 accu min aansluiting.
G	Start accu plus aansluiting
H	Aansluitklemmen voor (van links naar rechts): temperatuur sensor plus, temperatuur sensor min.
I	Dubbele M8 accu plus aansluiting.
J	Wisselspanning ingang (walstroom/netspanning) AC-in-2. Van links naar rechts: L (fase), N (nul), PE (aarde).
K	Drukknoppen om de instellingen in het microprocessor geheugen op te slaan.
L	Aansluitklemmen voor afstandbedieningsschakelaar. Verbind de linker klem en de middelste klem om de Quattro aan te schakelen. Verbind de rechter klem en de middelste klem voor 'alleen laden'.
M	Instel DIP switches.
N	30A thermische onderbreker in serie met AC-in-1 (onderkast kast, links).
O	30A thermische onderbreker in serie met AC-in-2 (onderkast kast, rechts).

APPENDIX B: Block diagram

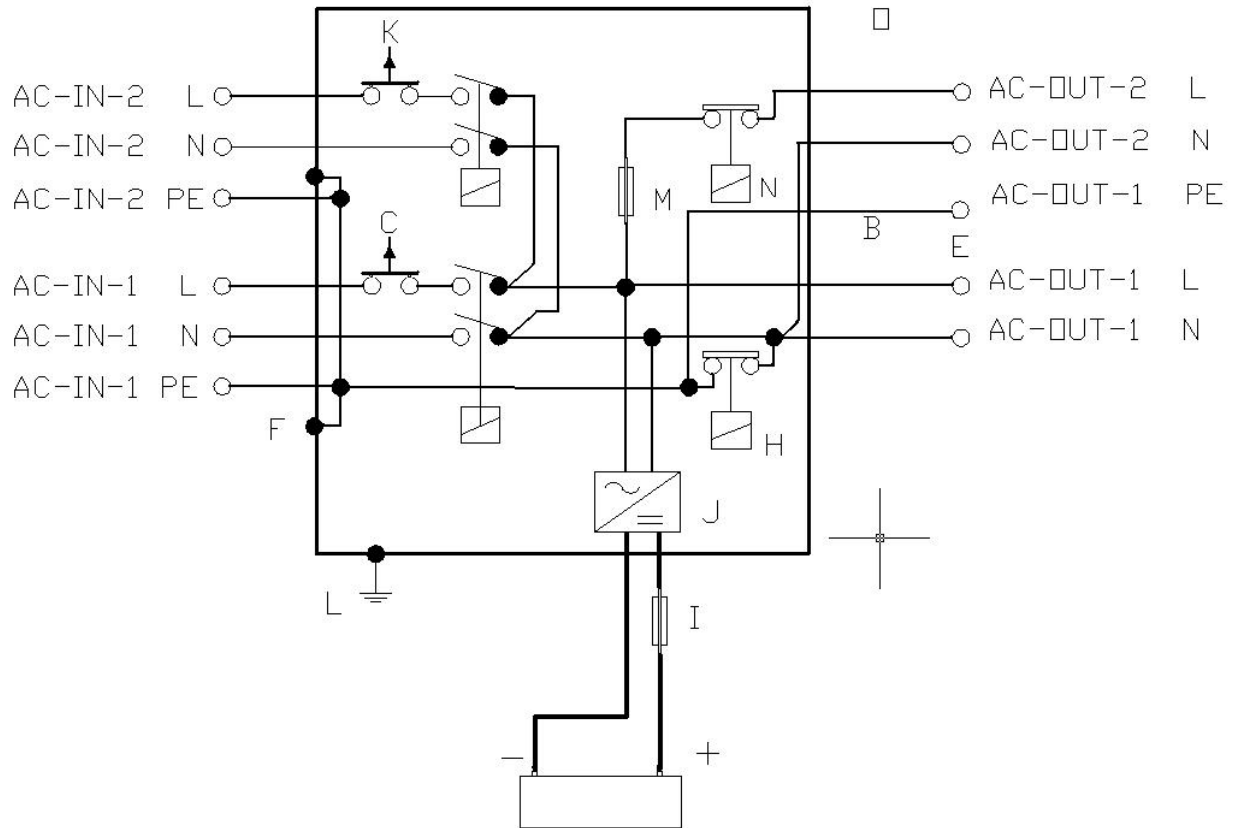

APPENDIX C: Parallel connection

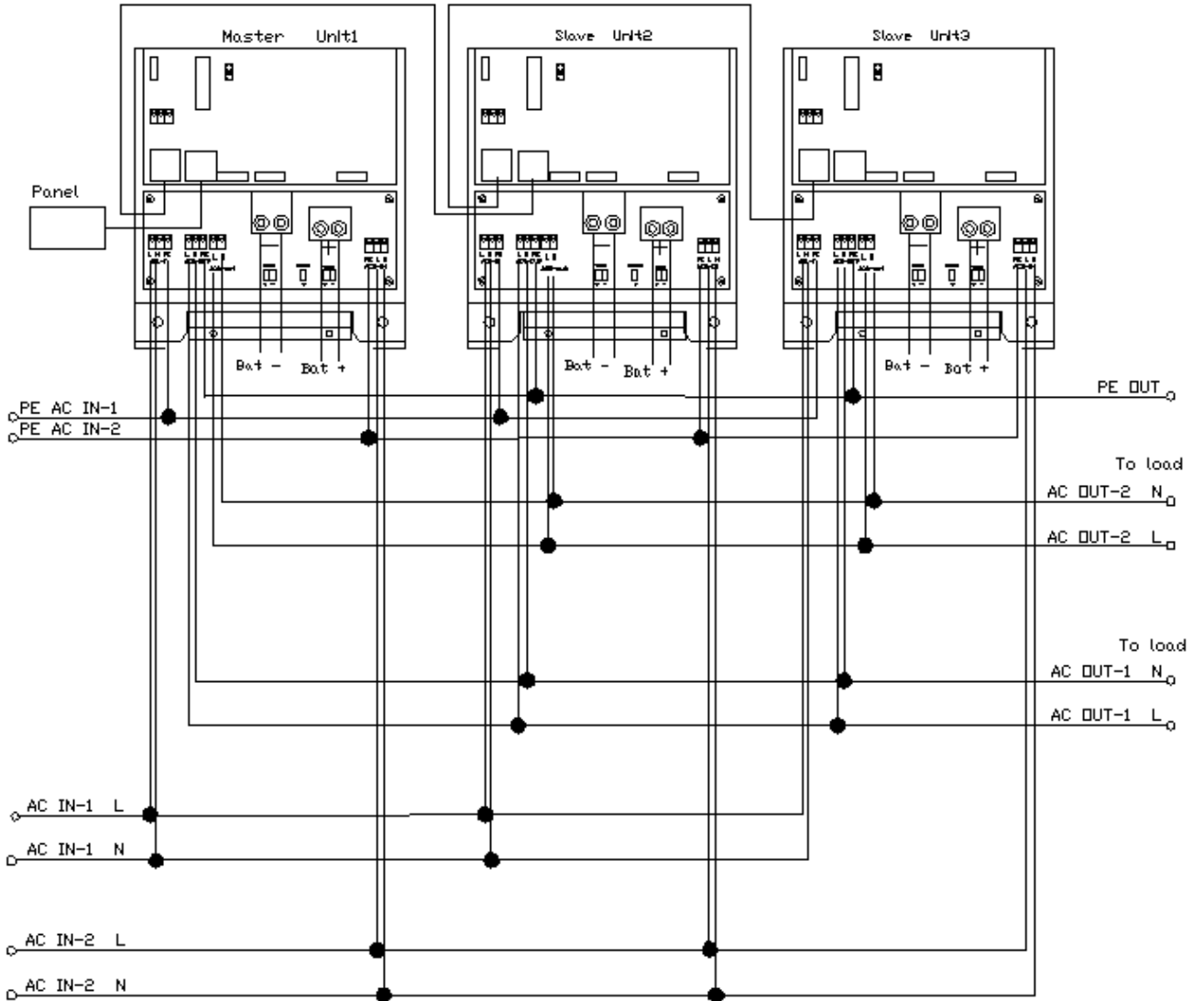

APPENDIX D: Three-phase connection

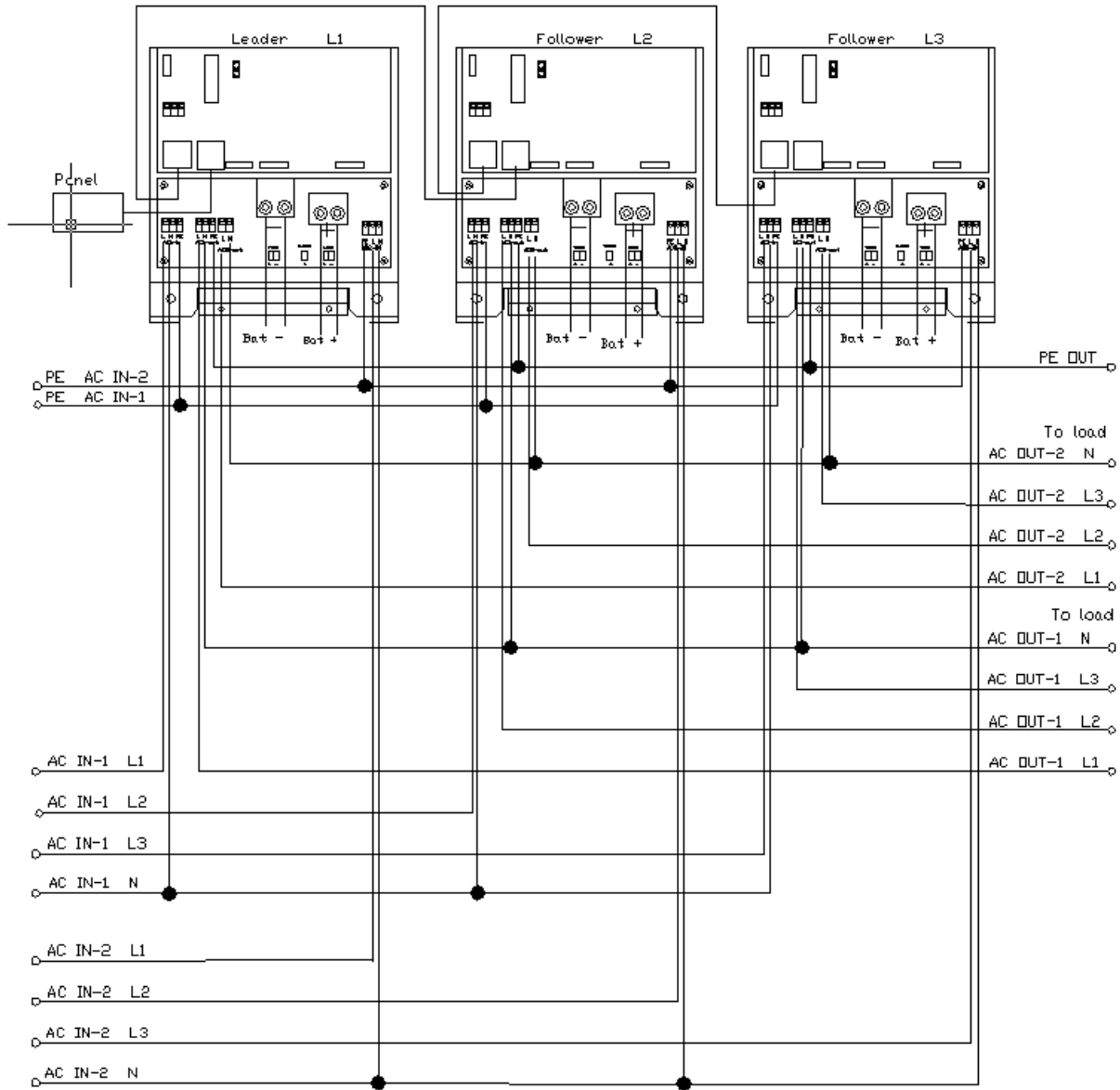

APPENDIX E: Charge characteristics

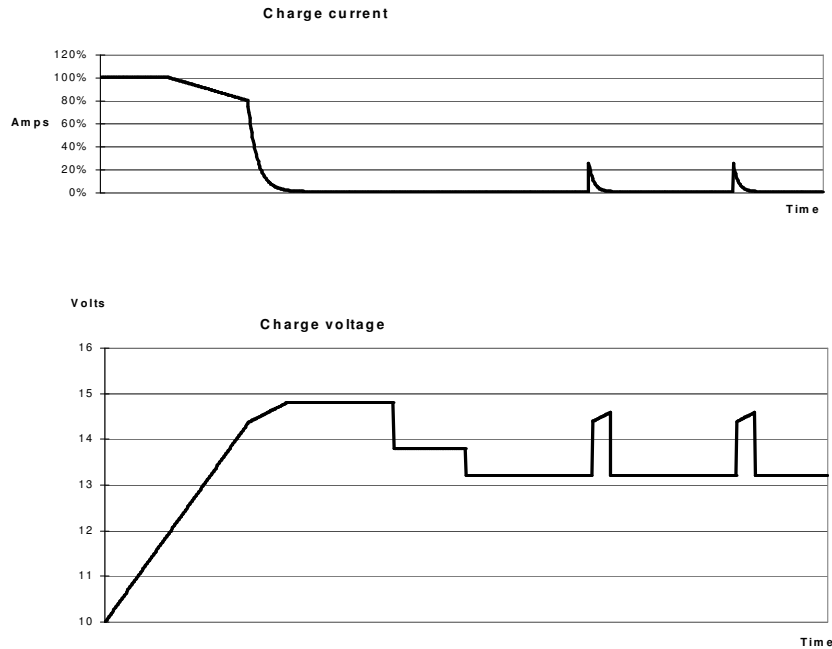

4-stage charging:

Bulk

Entered when charger is started. Constant current is applied until nominal battery voltage is reached, depending on temperature and input voltage, after which constant power is applied up to the point where excessive gassing is starting (14.4V resp. 28.8V, temperature-compensated).

Battery Safe

The applied voltage to the battery is raised gradually until the set Absorption voltage is reached. The Battery Safe Mode is part of the calculated absorption time.

Absorption

The absorption period is dependent on the bulk period. The maximum absorption time is the set Maximum Absorption time.

Float

Float voltage is applied to keep the battery fully charged

Storage

After one day of float charge the output voltage is reduced to storage level. This is 13,2V resp. 26,4V (for 12V and 24V charger). This will limit water loss to a minimum when the battery is stored for the winter season.

After an adjustable time (default = 7 days) the charger will enter Repeated Absorption mode for an adjustable time (default = one hour) to 'refresh' the battery.

APPENDIX F: Temperature compensation

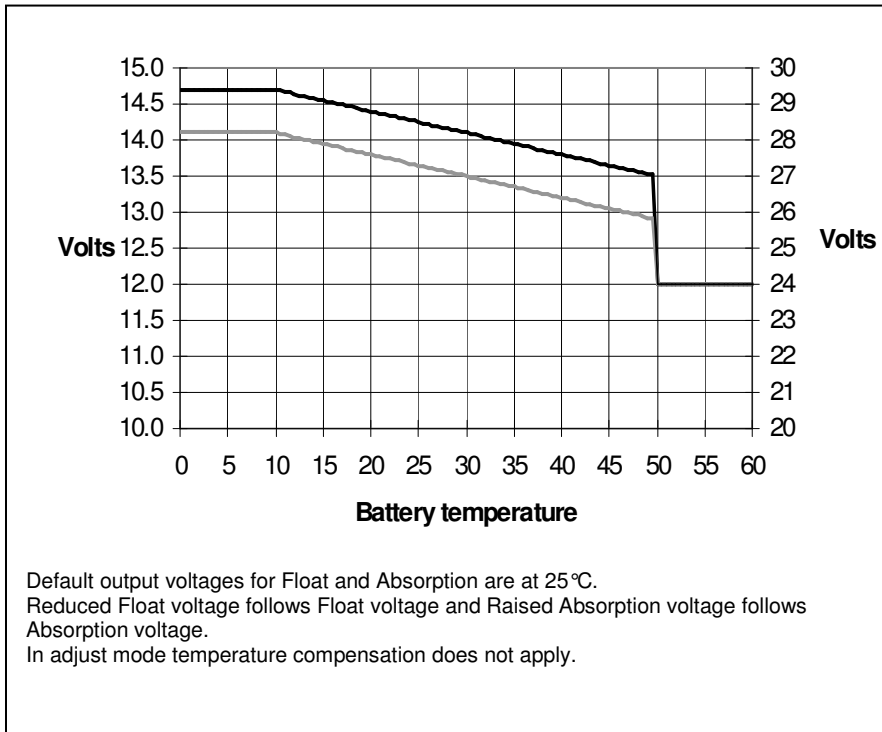

APPENDIX G: Dimensions

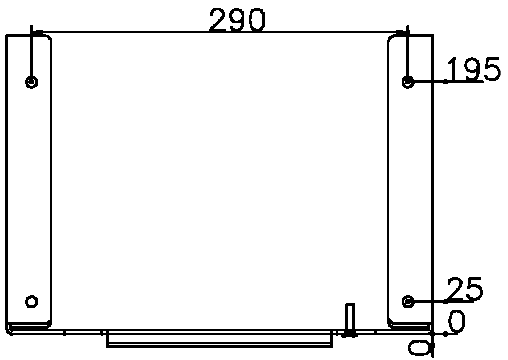
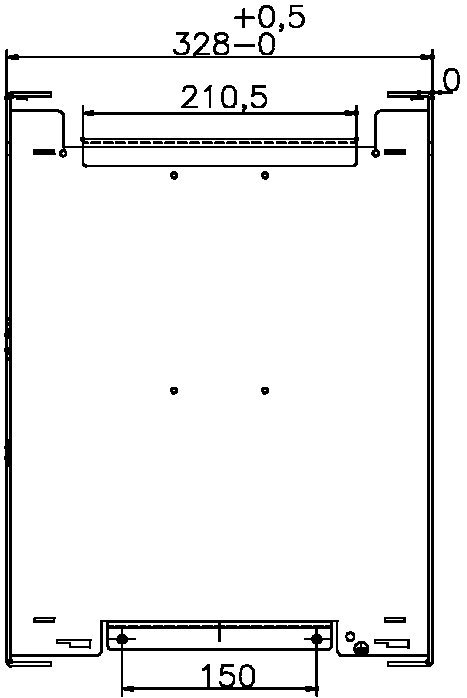
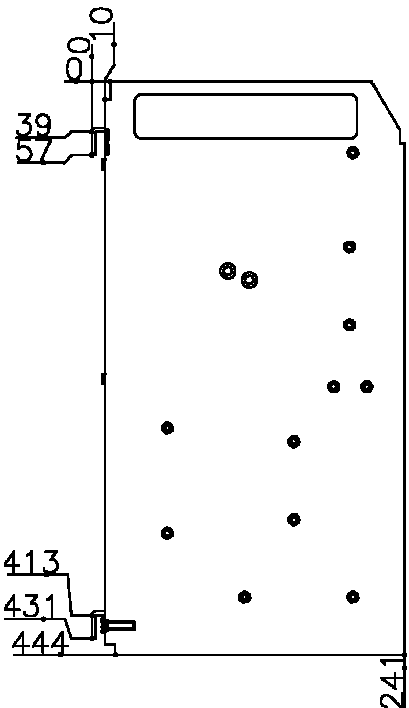
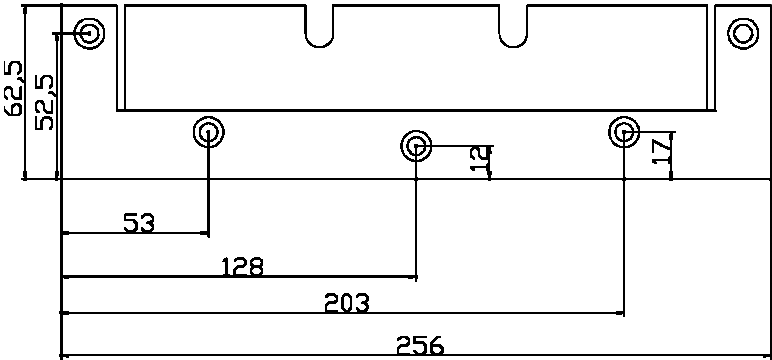

Serial number:

Distributor:

Victron Energy B.V.
The Netherlands

Phone: +31 (0)36 535 97 00
Fax: +31 (0)36 535 97 40
E-mail: sales@victronenergy.com
Web site: <http://www.victronenergy.com>

Article number:
Version:
Date:

ISMQUATTRO5000_GB
02
20-09-2007